

WITH MOUNTING CLIPS

8:1

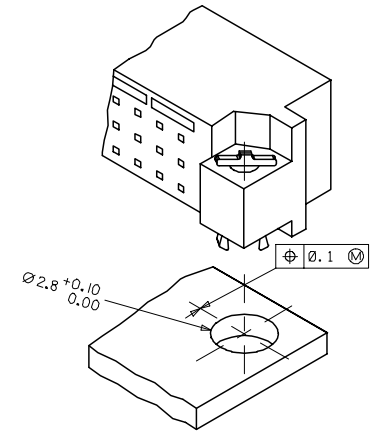
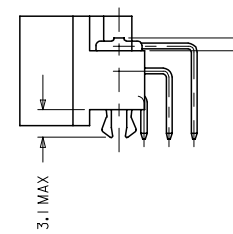

NOTES:

- MATERIALS: THERMOPLASTIC POLYESTER, GLASS FILLED, UL94V-0, COLOUR: PEBBLE GREY RAL 7032
TERMINAL - BRASS
MOUNTING CLIP: STEEL
- FINISH: TERMINAL:-
CONTACT AREA
I. PERFORMANCE LEVEL 4: SELECTIVE GOLD (Au), THICKNESS = 0.05 MICROMETER
OVER NICKEL, THICKNESS = 1.50 MICROMETER
TERMINATION AREA:
SELECTIVE TIN, THICKNESS = 2.5 MICROMETER
OVER NICKEL, THICKNESS = 1.50 MICROMETER OVERALL
- MOUNTING CLIP:-
TIN (Sn), THICKNESS = 5-10 MICROMETER,
OVER NICKEL (Ni), THICKNESS = 2.5 MICROMETER
- FOR NON MOUNTING CLIP OPTION, CONNECTOR TO BE SECURED WITH
RIVETS: 2 TUBULAR RIVETS 2.5 x 0.3 ... DIN 7340
SCREWS: 2 CHEESEHEAD SCREWS M2.5 x ... DIN 84 AND 2 HEXAGONAL NUTS M2.5 DIN 934
- MATERIAL NUMBER, BATCH CODE, UL AND CSA MARKING
TO BE PRINTED ON THE CONNECTOR
- CUT FACE OF TIP WITHOUT PLATING PERMITTED
- PRODUCT SPECIFICATION : PS-36502-001

RECOMMENDED PCB LAYOUT
COMPONENT SIDE

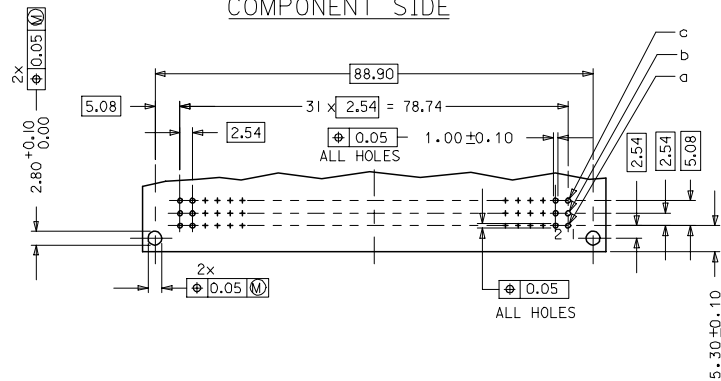

RoHS COMPLIANT

ENTER DESCRIPTION ELC.MC.12007-0502 2007/06/23 DRWING:BNMWAR 2007/06/23 CHK:KPRASAD 2007/06/23 APPR:KPRASAD 2007/06/23	QUALITY SYMBOLS ▽=0 ▽=0	GENERAL TOLERANCES (UNLESS SPECIFIED)		DIMENSION STYLE MM ONLY	SCALE 2:1	DESIGN UNITS METRIC	THIRD ANGLE PROJECTION
		4 PLACES ± --- ± --- 3 PLACES ± 0.05 ± --- 2 PLACES ± 0.1 ± --- 1 PLACE ± 0.15 ± ---	INCH --- --- ---	DRAWN BY SS	DATE 1999/09/01	TITLE ASSEMBLY, DIN 41612 C MALE 96 POS	MATERIAL NO. SEE CHART
DRAFT WHERE APPLICABLE MUST REMAIN WITHIN DIMENSIONS		SIZE A1		THIS DRAWING CONTAINS INFORMATION THAT IS PROPRIETARY TO MOLEX INCORPORATED AND SHOULD NOT BE USED WITHOUT WRITTEN PERMISSION			

20	19	18	17	16	15	14	13	12	11	10	9	8	7	6	5	4	3	2	1
MATERIAL No	MOLEX ENG No	PERF LEVEL	PLATING	CONTACT SEQUENCE/ROW	PREMATING CONTACT POS.	MOUNTING CLIP													
36502-0137	MM-B 1800-C960	4	Au+Ni	1,2,3....32 a+b+c	NO	NO													

DETAILY DETAILX

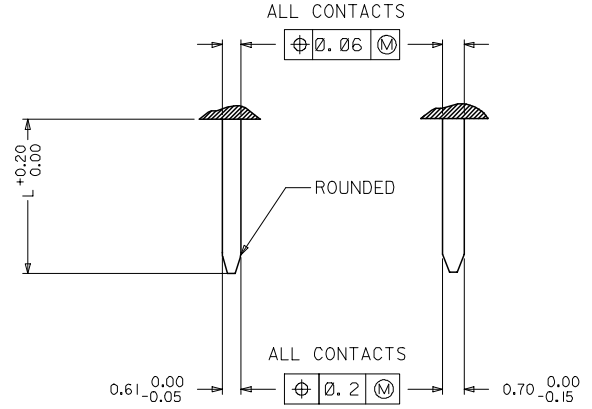

PRE MATING CONTACTS	5.4
NORMAL CONTACTS	4.8
	L

RoHS COMPLIANT

ENTER DESCRIPTION ELC.MC1.12007.0502 DRAWING: BINAAR 2007/06/23 CHK:KPRASAD 2007/06/23 APPR:KPRASAD 2007/06/23	QUALITY SYMBOLS ▽=0 ▽=0	GENERAL TOLERANCES (UNLESS SPECIFIED)		DIMENSION STYLE MM ONLY	SCALE 2:1	DESIGN UNITS METRIC	THIRD ANGLE PROJECTION	
		4 PLACES ± --- ± --- 3 PLACES ± 0.05 ± --- 2 PLACES ± 0.1 ± --- 1 PLACE ± 0.15 ± ---	.mm .INCH ± --- ± --- ± --- ± --- ± --- ± ---	DRAWN BY: SS DATE: 1999/09/01	CHECKED BY: G.J.LOWE DATE: 1999/09/01	ASSEMBLY, DIN 41612 C MALE 96 POS		
		ANGULAR ± 2°		APPROVED BY: G.J.LOWE DATE: 1999/09/01	MOLEX INCORPORATED			
		DRAFT WHERE APPLICABLE MUST REMAIN WITHIN DIMENSIONS		MATERIAL NO. SEE CHART SIZE: A 1	DOCUMENT NO. SD-36502-022	SHEET NO. 2 OF 2		