

REV.	ECN NO.	REVISIONS	DRN.	CKD.	APP.	DATE
A		NEW RELEASE	DC			

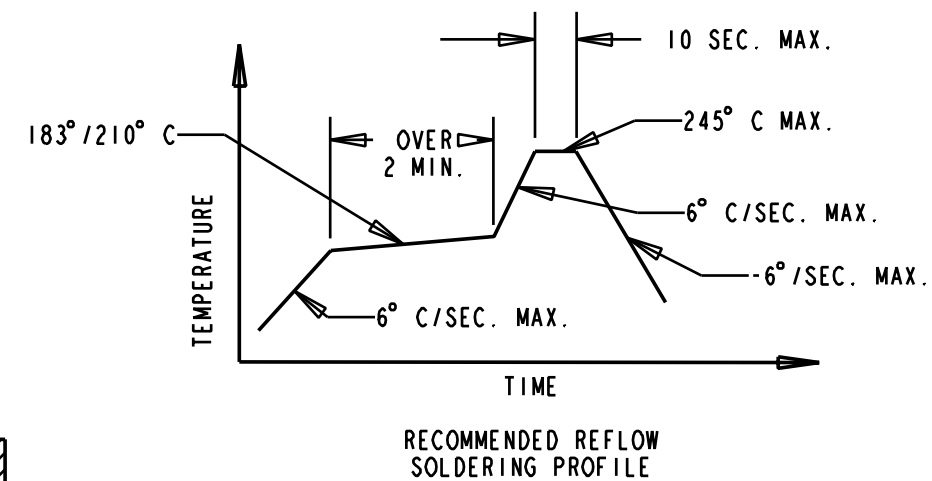
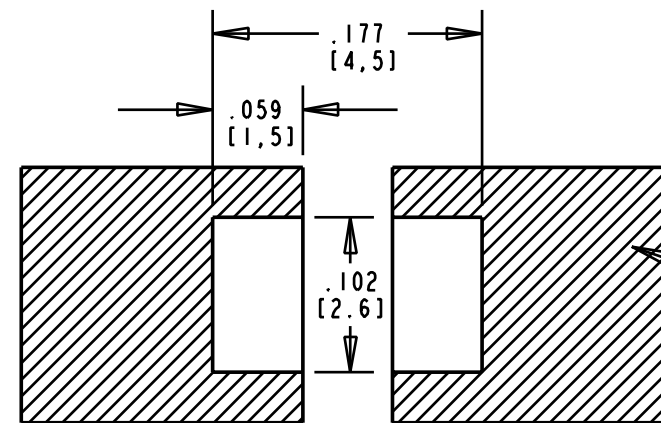
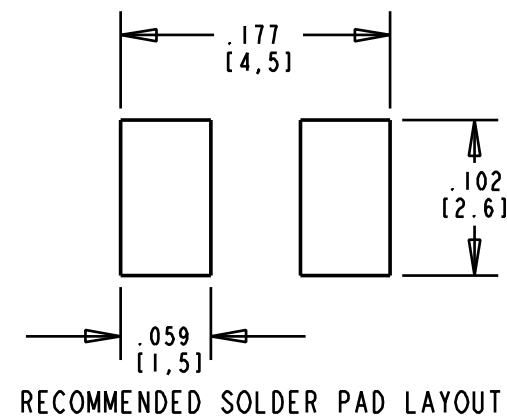
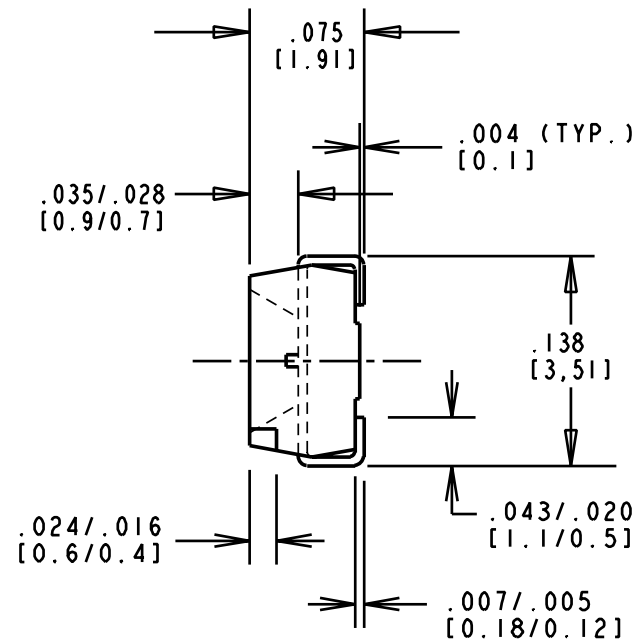
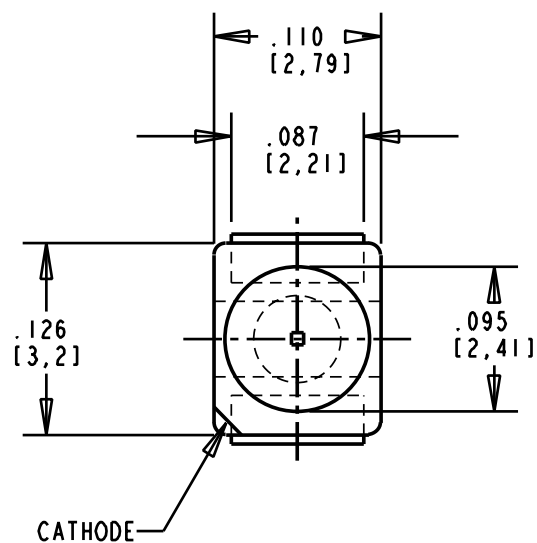

OPERATING CHARACTERISTICS AT 25° C AMBIENT

LED CHARACTERISTICS	MIN.	TYP.	MAX.	UNITS	TEST CONDITIONS
LUMINOUS INTENSITY	90.0		180.0	mc d	$I_f = 20 \text{ mA}$
FORWARD VOLTAGE		3.5	4.2	V	$I_f = 20 \text{ mA}$
REVERSE CURRENT		0.01	10	μA	$V_R = 5 \text{ V}$
VIEWING ANGLE (2 θ 1/2)		120		DEGREES	
COLOR COORDINATES	X	0.29	0.32	0.365	$I_f = 20 \text{ mA}$
	Y	0.22	0.31	0.42	

PAD LAYOUT FOR IMPROVED HEAT DISSIPATION

ABSOLUTE MAXIMUM RATINGS AT 25° C AMBIENT	
POWER DISSIPATION	85 mW
CONTINUOUS FORWARD CURRENT	20 mA
DERATE LINEARLY FROM 75° C	0.6 mA/°C
PEAK REVERSE VOLTAGE	5 V
SOLDERING PROFILE: IR - 235° C PEAK. - 15 SEC., 185° C - 90 SEC. MAX.	
OPERATING TEMPERATURE	-40° C TO +100° C
STORAGE TEMPERATURE	-40° C TO +100° C

NOTES:

- EPOXY COLOR: DIFFUSED
- DIE: InGaN.
- LEADS: SOLDER PLATED.
- SOLDER ADHERANCE: BOTH LEADS PER MIL-STD-202E, METHOD 208C.
- SUFFIX -202 FOR 20-PCS ON A SAMPLE TAPE STRIP.
SUFFIX -207 FOR 7" (178mm) DIA. REEL, .315(8mm) EMBOSSED CARRIER TAPE, WITH 2000 PARTS/REEL.
- PARTS TO BE TAPED AND REELED PER EIA-RS-481A.
- PARTS TO BE SUPPLIED 2000 DEVICES PER REEL WITH ALL PARTS ON ONE REEL FROM SAME LOT AND SAME BIN CATEGORY.
- LABELING: REELS TO BE IDENTIFIED WITH P/N, QUANTITY, DATE CODE, INTENSITY BIN CATEGORY AND COLOR BIN CATEGORY.
- PACKAGING IN SEALED ALUMINUM MOISTURE BARRIER BAG WITH DESICCANT AND "MOISTURE SENSITIVITY LEVEL OF "2" PER JEDEC J-STD-033.
- ATTENTION: OBSERVE PRECAUTIONS FOR HANDLING ELECTROSTATIC SENSITIVE DEVICES.
- DEVICES POSITIONED ON REEL WITH CATHODE SIDE TOWARDS SPROCKET.
- TAPE AND REEL LEDS MAY REQUIRE RE-TAPING AFTER TWELVE MONTHS.
- DIALIGHT P/N: 597-3901-202, 597-3901-207.

THIS DRAWING AND THE CONTENTS HEREIN ARE CONFIDENTIAL AND THE SOLE PROPERTY OF DIALIGHT. REPRODUCTION OF THIS DRAWING OR CONSTRUCTION OF ANY PARTS WITHIN THIS DRAWING ARE FORBIDDEN WITHOUT THE WRITTEN CONSENT OF DIALIGHT.		
SCALE 8:1 ALL DIM'S IN: INCHES (MM)	DRAWING NUMBER C-16903	REV A
TOLERANCES: UNLESS OTHERWISE SPECIFIED FRACTIONS: $\pm 1/64$ DECIMALS (.XX): $\pm .010$ DECIMALS (.XXX): $\pm .008$	TITLE WHITE PLCC SMT LED	
ANGLES: $\pm 1^\circ$	MATERIAL	
FINISH:	Dialight	1501 ROUTE 34 SOUTH FARMINGDALE, NJ 07727
FSCM 83330	SHEET OF	FAMILY TABLE: