

**LT8491**

# High Voltage Buck-Boost Battery Charge Controller with Maximum Power Point Tracking (MPPT) and I<sup>2</sup>C

## DESCRIPTION

The DC2703A-A-KIT contains the DC2703A (LT®8491 demo board) and DC1613A (USB-to-I<sup>2</sup>C controller). Together they provide a high performance buck-boost battery charger converter with an I<sup>2</sup>C interface. The LT8491 implements a maximum power point tracking (MPPT) function and flexible charging profiles, suitable for most battery types such as flooded and sealed lead acid batteries and Li-Ion batteries. A Microsoft Windows-Based GUI (Graphical User Interface) application called “simpleLT8491” is provided which can be downloaded [here](#).

The DC2703A-A-KIT demo board is configured for 17V to 54V input voltage range and the power source can be a solar panel with 36 to 72 cells (up to 200W) or a DC voltage source. The LT8491 converter can operate from input voltages above, below or equal to the battery voltage. Two input connectors are provided. An ideal diode controller LTC®4359 protects the DC power supply output from being back fed from the solar panel. This allows, for example, a 24VDC supply to be plugged in while a solar panel with higher voltage is being used to power the circuit. The DC2703A-A-KIT demo board output is set up for charging a 12V SLA battery with up to 16.6A charge current. The DC2703A-A-KIT demo board can be modified to support much higher output voltage, with modifications including higher voltage rating output side MOSFETs and capacitors.

The LT8491 includes a slave I<sup>2</sup>C compatible interface for digital control of the charger settings and digital readouts of charger telemetry and status. A Microsoft Windows-Based GUI (Graphical User Interface) application is provided for this demo board, which makes it very easy to read charger telemetry and status data, as well as the

ability to change the charging algorithm by writing to the appropriate configuration registers. The LT8491 EEPROM on the DC2703A-A-KIT demo board is programmed with the onboard resistor values to accurately read charger telemetry and status registers data.

On-chip logic provides automatic true power point tracking (MPPT) for solar powered applications. The MPPT function not only continuously tracks the maximum power point, but also periodically sweeps the input panel voltage in order to select the correct maximum on the power curve. In doing so, an increase in power harvested from the panel during partial shade conditions is possible when multiple peaks occur on the power curve. During periods of low light, a low power mode allows the charger to deliver a small charge current even if there is not enough light for the MPPT function to operate.

An RJ25 modular jack can be used to connect an external NTC temperature sensor mounted at the battery. This allows temperature compensation of the charge voltage, which is important for lead acid batteries. The same connector can be used for remote sensing of battery voltage, to compensate for voltage drops in long battery cables. The onboard LED displays the charge state.

The LT8491 data sheet gives a complete description of the device, operation and application information. The data sheet must be read in conjunction with this demo manual for DC2703A-A-KIT. The LT8491EUKJ is assembled in a 64-lead (7mm × 11mm) plastic QFN package with a thermal pad underneath the chip. Proper board layout is essential for maximum thermal performance.

**[Design files for this circuit board are available.](#)**

All registered trademarks and trademarks are the property of their respective owners.

# DEMO MANUAL

## DC2703A-A-KIT

### PERFORMANCE SUMMARY Specifications are at $T_A = 25^\circ\text{C}$

SYMBOL	PARAMETER	CONDITIONS	MIN	TYP	MAX	UNITS
$V_{IN}$	Input Supply Range	Note: Output Power Is Limited by Input Current Limit When $V_{IN} < 24\text{V}$ (See Figure 2)	17	30	54	V
$V_{OUT}$	Charge Voltage			14.2		V
$I_{IN}$	Maximum Input Current			10		A
$I_{OUT}$	Maximum Output Current	$V_{IN} > 24\text{V}, V_{OUT} = 12\text{V}$		16.6		A
$f_{SW}$	Switching Frequency			150		kHz
$P_{OUT}/P_{IN}$	Efficiency at DC Input	$V_{IN} = 48\text{V}, V_{OUT} = 14.2\text{V}, I_{OUT} = 15\text{A}$ $V_{IN} = 36\text{V}, V_{OUT} = 14.2\text{V}, I_{OUT} = 15\text{A}$ $V_{IN} = 24\text{V}, V_{OUT} = 14.2\text{V}, I_{OUT} = 8\text{A}$		95.6 96.1 97.1		% % %

**Note 1:**  $V_{IN}$  MIN and MAX specifications are for solar panel as an input power source. For further information refer to data sheet section: HW Config: Solar Panel Powered Charging. For DC supply as an input power source,  $V_{IN}$  MIN can be as low as 10V.

### TYPICAL PERFORMANCE CHARACTERISTICS

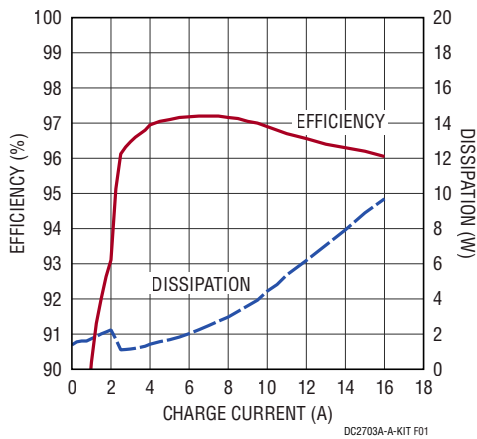

**Figure 1. Efficiency vs Output Battery Charge Current (DC Input:  $V_{IN} = 28\text{V}, V_{OUT} = 14.2\text{V}$ )**

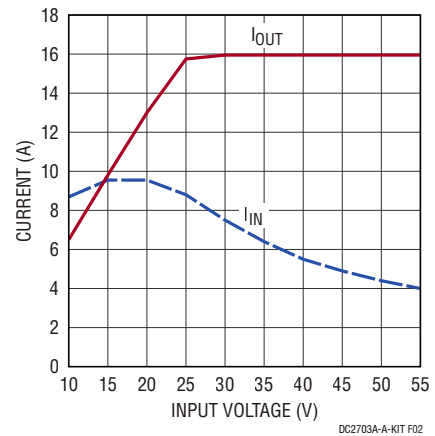

**Figure 2. Input and Output Currents vs Input Voltage (DC Input Current Limited to 10A,  $V_{OUT} = 13.6\text{V}$ )**

### QUICK START PROCEDURE

1. Connect a 12V lead acid battery to the VBAT connector (J2), making sure that the polarity is correct. A suitable battery size is a 150Ah 12V deep cycle sealed lead acid battery, but also smaller 12V lead acid batteries can be used for testing the charging functions. Use a short battery cable that is rated for 15A or higher.
2. Connect the solar panel to the PANEL IN connector (J1), making sure that the polarity is correct. A suitable panel is a 200W 60 cell solar panel, but any panel with 36 to 72 cells (54V maximum open circuit voltage) can be used.
3. Download and install the Windows-Based GUI (Graphical User Interface) application called “simpleLT8491”. Refer to the GUI application user guide (from the GUI window select Help > User Guide) to explore the full functionality of the GUI. The communication between the Windows-Based PC and DC2703A-A-KIT demo board is done using either a [DC1613A](#) or a [DC2026C](#) Linduino®, which are USB-based controllers. Connect the DC1613A or the DC2026C Linduino to the PC USB port using a USB cable. If using a DC1613A, connect the output of the DC1613A to the DC1613A PORT connector (J9) on the DC2703A-A-KIT demo board. If using a DC2026C Linduino, connect the output of the DC2026C Linduino to the Linduino HDR connector (J10) on the DC2703A-A-KIT demo board.  
  
Note: If using the DC2026C Linduino, the user will need to make sure that it has the appropriate sketch loaded before interfacing with the DC2703A-A-KIT demo board. Refer to the GUI application user guide on how to load the appropriate sketch.
4. Point the solar panel towards sunlight to power the charger and monitor the MPPT charger function under different conditions, using ampere meters and voltmeters and other test equipment as needed. Run the

“simpleLT8491” application by selecting it from the Windows START menu. In the GUI window under “LT8491 Address” section, it will display “Address 1 0x10” indicating that LT8491 with I<sup>2</sup>C chip address 0x10 has been detected. Click the Poll or One Shot button to display the charger telemetry and status registers data in the GUI Dashboard tab. In the event the GUI application is running but the DC2703A-A-KIT demo board is power cycled or LT8491 is reset, reconnect the GUI application and demo board by selecting from GUI window “Tools > Connect Interface”.

Note: By default, the charger will not start unless the output battery voltage is above 4.5V. However, this threshold can be changed by writing to CFG\_UV\_S0/CFG\_S0\_UV configuration registers if needed. For further information refer to I<sup>2</sup>C Register Descriptions: CFG\_UV\_S0, CFG\_S0\_UV in the data sheet.

5. The charger will also work with a DC power supply connected to the DC IN connector (J7). Disconnect the solar panel before turning on the DC supply. (The charger can operate from both power sources simultaneously. However, the MPPT function will be disabled while there is DC voltage on the DC IN input, so the solar panel may not be operating at its maximum power point if the charger is also powered from the DC IN connector.) A suitable supply is a 24VDC supply that can deliver at least 12A, but any DC power supply that has an output voltage in the range of 10V to 54V and is able to deliver 250W power or 12A current can be used for evaluation.
6. Read the LT8491 data sheet for more details on the function of the circuit and how to change the charging algorithm by writing to the appropriate configuration registers via the I<sup>2</sup>C interface.

## QUICK START PROCEDURE

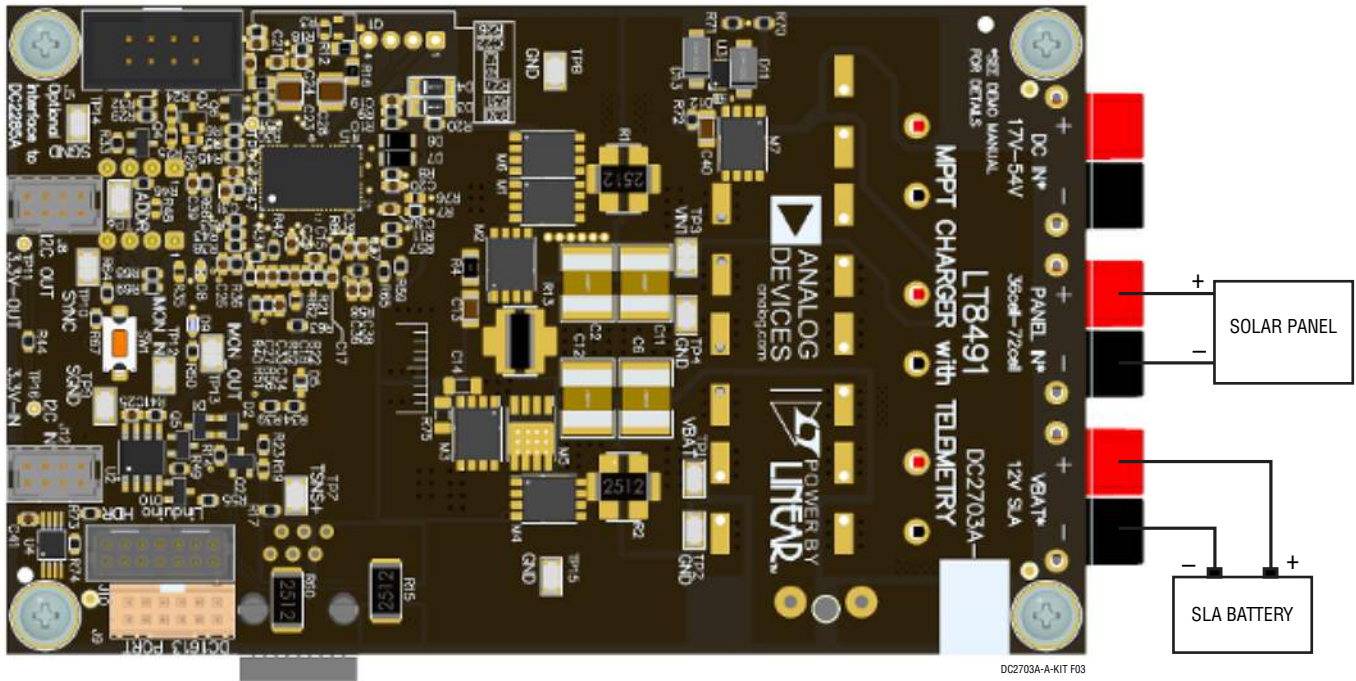

Figure 3. SOLAR Panel and SLA Battery Connections

## QUICK START PROCEDURE

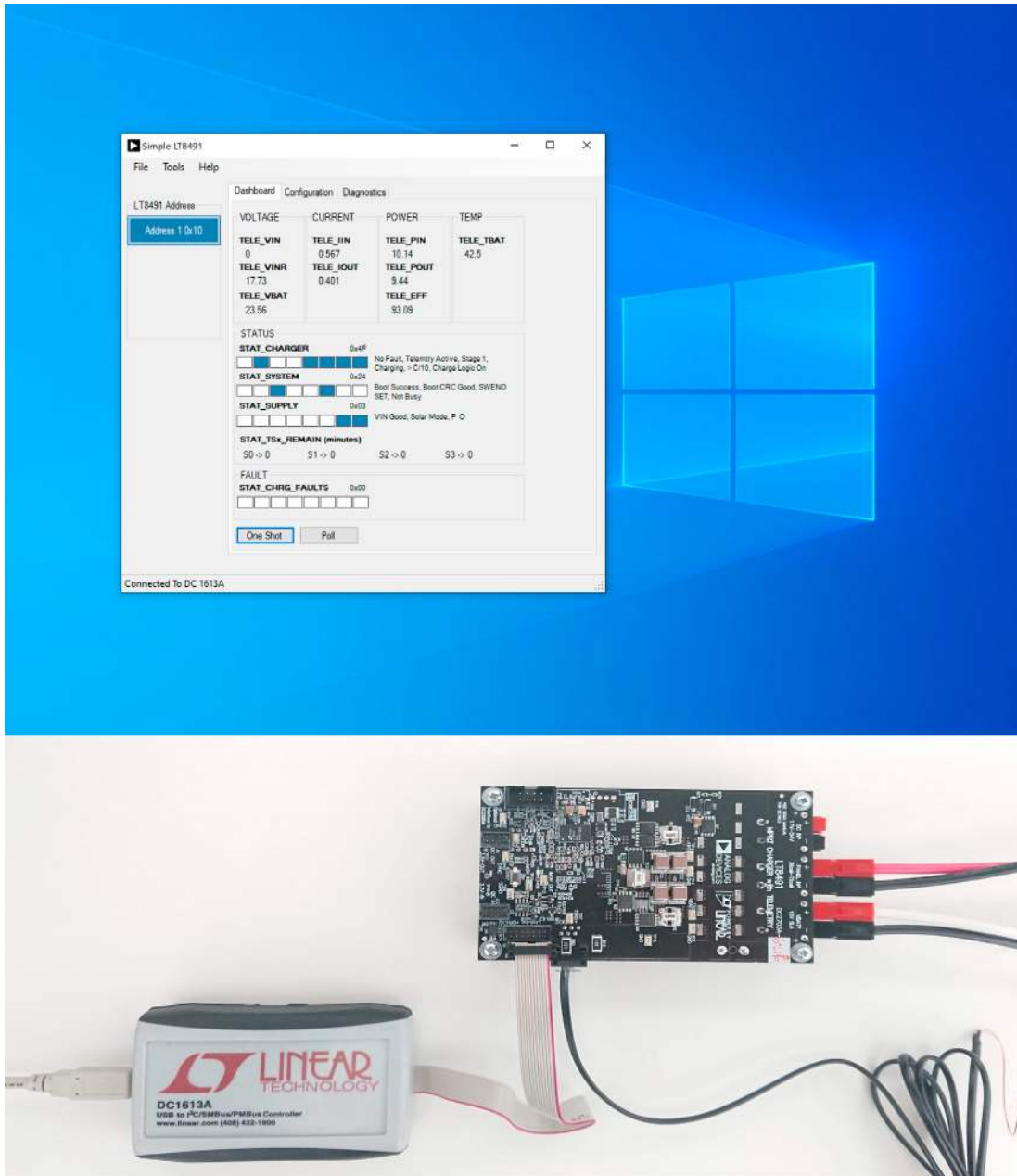

Figure 4. DC2703A-A-KIT Connected to DC1613A and Windows-Based GUI “simpleLT8491” Application

# DEMO MANUAL

## DC2703A-A-KIT

### PARTS LIST

ITEM	QTY	REFERENCE	PART DESCRIPTION	MANUFACTURER/PART NUMBER
<b>Required Circuit Components</b>				
1	4	C2, C6, C11, C12	CAP, 10 $\mu$ F, X7R, 100V, 20%, 2220, STACKED	TDK, CKG57NX7R2A106M
2	1	C3	CAP, 150 $\mu$ F, ALUM.ELECT., 25V, 20%, 8mm $\times$ 10.5mm SMD	SUN ELECTRONIC INDUSTRIES, 25HVH150M
3	2	C4, C8	CAP, 33 $\mu$ F, ALUM. ELECT., 63V, 20%, 10mm $\times$ 10.5mm SMD	SUN ELECTRONIC INDUSTRIES, 63HVH33M
4	1	C13	CAP, 0.001 $\mu$ F, X7R, 100V, $\pm$ 10%, 1206	WURTH ELEKTRONIK, 885012208106
5	1	C15	CAP, 1000pF, X7R, 16V, 10%, 0603	AVX, 0603YC102KAT2A
6	2	C16, C21	CAP, 0.01 $\mu$ F, X7R, 100V, 10%, 0603	WURTH ELEKTRONIK, 885012206114
7	2	C17, C18	CAP, 0.0033 $\mu$ F, X7R, 50V, 10%, 0603	WURTH ELEKTRONIK, 885012206086
8	2	C19, C20	CAP, 0.220 $\mu$ F, X7R, 16V, 10%, 0603	WURTH ELEKTRONIK, 885012206048
9	2	C22, C24	CAP, 0.470 $\mu$ F, X7R, 16V, 10%, 0603	WURTH ELEKTRONIK, 885012206050
10	1	C23	CAP, 2.2 $\mu$ F, X7R, 100V, 10%, 1210	AVX, 12101C225KAT2A
11	3	C26, C34, C37	CAP, 0.1 $\mu$ F, X7R, 16V, 10%, 0603	AVX, 0603YC104KAT2A
12	2	C27, C32	CAP, 1 $\mu$ F, X7R, 16V, 10%, 0603	WURTH ELEKTRONIK, 885012206052
13	1	C28	CAP, 1 $\mu$ F, X7R, 100V, 10%, 1210	AVX, 12101C105KAT2A
14	3	C29, C30, C31	CAP, 4.7 $\mu$ F, X5R, 16V, 20%, 0603	MURATA, GRM188R61C475MAAJD
15	2	C33, C35	CAP, 0.0047 $\mu$ F, X7R, 16V, 10%, 0603	WURTH ELEKTRONIK, 885012206038
16	1	C36	CAP, 220pF, C0G, 50V, 5%, 0603	AVX, 06035A221JAT2A
17	1	C38	CAP, 0.0068 $\mu$ F, X7R, 50V, 10%, 0603	WURTH ELEKTRONIK, 885012206088
18	1	C39	CAP, 0.068 $\mu$ F, X7R, 16V, 10%, 0603	WURTH ELEKTRONIK, 885012206045
19	2	D3, D4	DIODE, RECT., 200V, 1A, SOD-123F	CENTRAL SEMI., CMMR1U-02 TR
20	2	D6, D7	DIODE, SCHOTTKY, 100V, 1A, POWERDI-123	DIODES INC., DFLS1100-7
21	1	L1	IND., 10 $\mu$ H, SHIELDED, HIGH CURRENT, 15%, 30A, 2.4m $\Omega$	WURTH ELEKTRONIK, 7443641000
22	2	M1, M6	XSTR., MOSFET, N-CH, 60V, PG-TDSON-8	INFINEON, BSC028N06NS
23	1	M2	XSTR., MOSFET, N-CH, 60V, 8-PIN PG-TDSON FL	INFINEON, BSC016N06NSATMA1
24	2	M3, M4	XSTR., MOSFET, N-CHAN, 25V, PG-TDSON-8	INFINEON, BSC010NE2LSI
25	1	R1	RES., 5m $\Omega$ , 1%, 2W, 2512	TT ELECTRONICS, LRMAT2512-R005FT4
26	1	R2	RES., SENSE, 3m $\Omega$ , 1%, 2W, 2512	TT ELECTRONICS, LRMAT2512-R003FT4
27	1	R4	RES., 1.2 $\Omega$ , 5%, 1/4W, 1206	VISHAY, CRCW12061R20JNEA
28	1	R5	RES., 30.1k, 1%, 1/10W, 0603	VISHAY, CRCW060330K1FKEA
29	1	R6	RES., 8.06k, 1%, 1/10W, 0603	YAGEO, RC0603FR-078K06L
30	4	R7, R9, R10, R47	RES., 1 $\Omega$ , 1%, 1/10W, 0603	YAGEO, RC0603FR-071RL
31	7	R8, R11, R23, R29, R36, R44, R66	RES., 0 $\Omega$ , 1/10W, 0603	BOURNS, CR0603-J/-000ELF
32	8	R12, R18, R21, R22, R26, R27, R41, R63	RES., 10 $\Omega$ , 1%, 1/10W, 0603	VISHAY, CRCW060310R0FKEA
33	1	R13	RES., 3m $\Omega$ , 1%, 3W, 1225, METAL, SENSE	SUSUMU, KRL6432E-M-R003-F-T1
34	6	R17, R49, R55, R58, R73, R74	RES., 4.99k, 1%, 1/10W, 0603	STACKPOLE, RMCFO603FT3R30
35	1	R20	RES., 3.3 $\Omega$ , 1%, 1/10W, 0603	STACKPOLE, RMCFO603FT3R30
36	1	R30	RES., 196k, 1%, 1/10W, 0603	VISHAY, CRCW0603196KfKEA
37	1	R31	RES., 102k, 1%, 1/10W, 0603	VISHAY, CRCW0603102KfKEA
38	1	R37	RES., 5.9k, 1%, 1/10W, 0603	PANASONIC, ERJ3EKf5901V
39	2	R38, R65	RES., 53.6k, 1%, 1/10W, 0603	VISHAY, CRCW060353K6fKEA

Rev. 0

### PARTS LIST

ITEM	QTY	REFERENCE	PART DESCRIPTION	MANUFACTURER/PART NUMBER
40	3	R39, R56, R59	RES., 10k, 1%, 1/10W, 0603	VISHAY, CRCW060310K0FKEC
41	1	R40	RES., 3.48k, 1%, 1/10W, 0603	VISHAY, CRCW06033K48FKEA
42	1	R42	RES., 1.1k, 1%, 1/10W, 0603	PANASONIC, ERJ3EKF1101V
43	1	R43	RES., 11.3k, 1%, 1/10W, 0603	PANASONIC, ERJ3EKF1132V
44	1	R46	RES., 49.9k, 1%, 1/10W, 0603	NIC, NRC06F4992TRF
45	1	R51	RES., 18.2k, 1%, 1/10W, 0603	PANASONIC, ERJ3EKF1822
46	1	R52	RES., 21k, 1%, 1/10W, 0603	ROHM, MCR03EZPFX2102
47	1	R53	RES., 3.01k, 1%, 1/10W, 0603	VISHAY, CRCW06033K01FKEA
48	1	R57	RES., 301k, 1%, 1/10W, 0603	NIC, NRC06F3013TRF
49	1	R61	RES., 124k, 1%, 1/10W, 0603	PANASONIC, ERJ3EKF1243V
50	1	R64	RES., 110k, 1%, 1/10W, 0603	PANASONIC, ERJ3EKF1103V
51	1	R67	RES., 35.7k, 1%, 1/10W, 0603	NIC, NRC06F3572TRF
52	1	U1	IC., BATTERY CHARGE CONTROLLER	ANALOG DEVICES, LT8491EUKJ#PBF

#### Additional Demo Board Circuit Components And Options

53	5	C1, C5, C7, C9, C10	CAP, OPTION, ALUM. ELECT., SMD	OPT
54	1	C14	CAP, OPTION, 1206	OPT
55	1	C41	CAP, 1 $\mu$ F, X7R, 16V, 10%, 0603	WURTH ELEKTRONIK, 885012206052
56	1	D8	LED, OPTION, 0603	OPT: LUMEX OPTO/COMPONENTS INC., SML-LX0603SIW-TR
57	1	D9	LED, GREEN, COLORLESS DIFFUSED, 0603	OSRAM, LG L29K-G2J1-24-Z
58	1	F1	FUSE BLADE FAST ACTING, 30A, 58V, 10.9mm x 3.8mm x 8.8mm	LITTLEFUSE, 0997030.WXN
59	1	FH1	FUSE HOLDER, 125V, 2-PIN, THT-HOLE	LITTELFUSE, 178.6764.0001
60	1	HL1	IND., OPTION	OPT
61	1	M5	XSTR., MOSFET, N-CHAN, 25V, PG-TDSON-8	OPT: INFINEON, BSC010NE2LSI
62	1	R24	RES., 0 $\Omega$ , 1/10W, 0603	OPT: BOURNS, CR0603-J/-000ELF
63	1	R35	RES., OPTION, 0603	OPT
64	1	R45	RES., 1.3k, 1%, 1/10W, 0603	VISHAY, CRCW06031K30FKEA
65	2	R48, R62	RES., OPTION, 0603	OPT
66	1	R50	RES., 549 $\Omega$ , 1%, 1/10W, 0603	VISHAY, CRCW0603549RFKEA
67	2	R68, R69	RES., 10k, 1%, 1/10W, 0603	VISHAY, CRCW060310K0FKEC
68	1	R75	RES., OPTION, 1206	OPT
69	1	R76	RES., 1 $\Omega$ , 1%, 1/10W, 0603	OPT: YAGEO, RC0603FR-071RL
70	1	SW1	SWITCH, TACT, NO SPST, 0.05A, 12V, J-BEND, SMD 6.0mm x 3.5mm	WURTH ELEKTRONIK, 434123050816
71	1	U4	IC., MEMORY, EEPROM, 2Kb (256x8), TSSOP-8	MICROCHIP, 24LC025-I/ST

#### Optional Remote Sense for VBAT: Installed

72	1	C25	CAP, 0.010 $\mu$ F, X7R, 16V, 10%, 0603	WURTH ELEKTRONIK, 885012206040
73	3	D1, D2, D10	DIODE, SWITCHING, 75V, 300mA, 350mW, SOT-23	DIODES INC., BAV99-7-F
74	1	D5	DIODE, OPTION, SOD-323	OPT
75	1	J3	CONN., RJ-25, FEMALE, 6-POS, 2.54mm, THT RA	TE CONNECTIVITY, 5555165-1
76	1	Q2	XSTR., MOSFET, P-CH, 50V, 0.13A, SOT23-3	FAIRCHILD SEMI, BSS84
77	2	Q4, Q5	XSTR., NPN, 40V, 200mA, SOT23-3	ON SEMICONDUCTOR, MMBT3904LT1G
78	1	R14	RES., 100k, 1%, 1/10W, 0603	YAGEO, RC0603FR-07100KL

# DEMO MANUAL

## DC2703A-A-KIT

### PARTS LIST

ITEM	QTY	REFERENCE	PART DESCRIPTION	MANUFACTURER/PART NUMBER
79	2	R15, R60	RES., 100Ω, 5%, 1W, 2512	PANASONIC, ERJ1TYJ101U
80	1	R19	RES., OPTION, 0603	OPT
81	1	R32	RES., 200k, 1%, 1/10W, 0603	NIC, NRC06F2003TRF
82	1	R33	RES., 27.4k, 1%, 1/10W, 0603	VISHAY, CRCW060327K4FKEA
83	1	R34	RES., 113k, 1%, 1/10W, 0603	PANASONIC, ERJ3EKF1133V
84	1	U2	IC., OP AMP, SO8	ANALOG DEVICES, LT1636CS8#PBF
<b>Optional DC Input Source: Installed</b>				
85	1	C40	CAP, 2.2μF, X7R, 100V, 10%, 1210	AVX, 12101C225KAT2A
86	1	D11	DIODE, TVS, UNI-DIRECT, 70V, 400W, SMA	DIODES INC., SMAT70A-13-F
87	1	D12	DIODE, ZENER, 12V, 150mW, SOD-523	DIODES INC., DDZ9699T-7
88	1	D13	DIODE, TVS, UNI-DIRECT, 24V, 400W, SMA	DIODES INC., SMAJ24A-13-F
89	1	J7	ANDERSON PP15/45 1x2 ASSEMBLED FROM MP1-MP15	ANDERSON POWER, MULTI-PART PP15
90	1	M7	XSTR., MOSFET, N-CH, 100V, 80A, PG-TDSON-8	INFINEON, BSC070N10NS5
91	1	Q6	XSTR., NPN, 40V, 200mA, SOT23-3	ON SEMICONDUCTOR, MMBT3904LT1G
92	1	R70	RES., 100k, 1%, 1/10W, 0603	YAGEO, RC0603FR-07100KL
93	1	R71	RES., 33.2k, 1%, 1/10W, 0603	PANASONIC, ERJ3EKF3322V
94	1	R72	RES., 1k, 1%, 1/10W, 0603	VISHAY, CRCW06031K00FKEA
95	1	U3	IC., IDEAL DIODE CONTROLLER, 6-PIN DFN EP	ANALOG DEVICES, LTC4359DCB#PBF
<b>Optional EXT<sub>CC</sub> Disconnect: Not Installed</b>				
96	1	Q1	XSTR., MOSFET, P-CH, 50V, 0.13A, SOT23-3	OPT: FAIRCHILD SEMI, BSS84
97	1	Q3	XSTR., NPN, 40V, 200mA, SOT23-3	OPT: ON SEMICONDUCTOR, MMBT3904LT1G
98	1	R3	RES., 100k, 1%, 1/10W, 0603	OPT: YAGEO, RC0603FR-07100KL
99	1	R16	RES., 10Ω, 1%, 1/10W, 0603	OPT: VISHAY, CRCW060310R0FKEA
100	1	R25	RES., 200k, 1%, 1/10W, 0603	OPT: NIC, NRC06F2003TRF
101	1	R28	RES., 26.1k, 1%, 1/10W, 0603	OPT: NIC, NRC06F2612TRF
<b>Hardware, Connectors, Etc.</b>				
102	2	J1, J2	ANDERSON PP15/45 1x2 ASSEMBLED FROM MP1-MP15	ANDERSON POWER, MULTI-PART PP15
103	2	J4, J6	CONN., HDR, MALE, 1x4, 2.54mm, STR, VERT, THT, AU	HTSW SERIES SAMTEC, HTSW-104-07-G-S
104	1	J5	CONN., HEADER SHROUDED, M, 8-POS, 2.54mm, THT- HOLE STR	WURTH ELEKTRONIK, 61200821621
105	2	J8, J12	CONN., HEADER, HDR, 8-POS, 2mm, ST THT-HOLE	AMPHENOL, 98414-G06-08ULF
106	1	J9	CONN., HDR, SHROUDED, MALE, 2x6, 2mm, VERT, ST, THT	AMPHENOL, 98414-G06-12ULF
107	1	J10	CONN., HDR, SHROUDED, MALE, 2x7, 2mm, VERT, ST, THT	MOLEX, 87831-1420
108	1	J11	CONN., HDR, MALE, 1x4, 2.54mm, STR, VERT, THT, AU	HTSW SERIES SAMTEC, HTSW-104-07-G-S
109	3	MP1, MP6, MP11	CONN., POWERPOLE, HOUSING, + PIN, RED, 15A, 1-POS	ANDERSON POWER PRODUCTS, 1327
110	3	MP2, MP7, MP12	CONN., POWERPOLE, HOUSING, - PIN, BLACK, 15A, 1-POS	ANDERSON POWER PRODUCTS, 1327G6
111	6	MP3, MP4, MP8, MP9, MP13, MP14	CONN., POWER, SKT, 25.7mm, RA/THT-HOLE	ANDERSON POWER PRODUCTS, 1377G12-BK
112	3	MP5, MP10, MP15	CONN., PCB MTG STAPLES, 1x2, STR, 12mm x 14.5mm	ANDERSON POWER PRODUCTS, 114555P2
113	4	MTG1, MTG2, MTG3, MTG4	SCREW, MACHINE, 4-40 x 3/4, PHILIPS PAN HEAD, STL, ZINC CR3	OLANDER CO, 4C25PPIZR
114	4	SO1, SO2, SO3, SO4	STANDOFF, F/F, HEX, 4-40 x 1-INCH	KEYSTONE, 2205
115	13	TP1, TP2, TP3, TP4, TP6, TP7, TP8, TP9,	TP10, TP12, TP13, TP14, TP15 TEST POINT, SILVER PLATE, PHOSPHOR BRONZE, 3.81mm x 2.03mm, 2.29mm H, SMT	KEYSTONE, 5019





# DEMO MANUAL DC2703A-A-KIT

## SCHEMATIC DIAGRAM

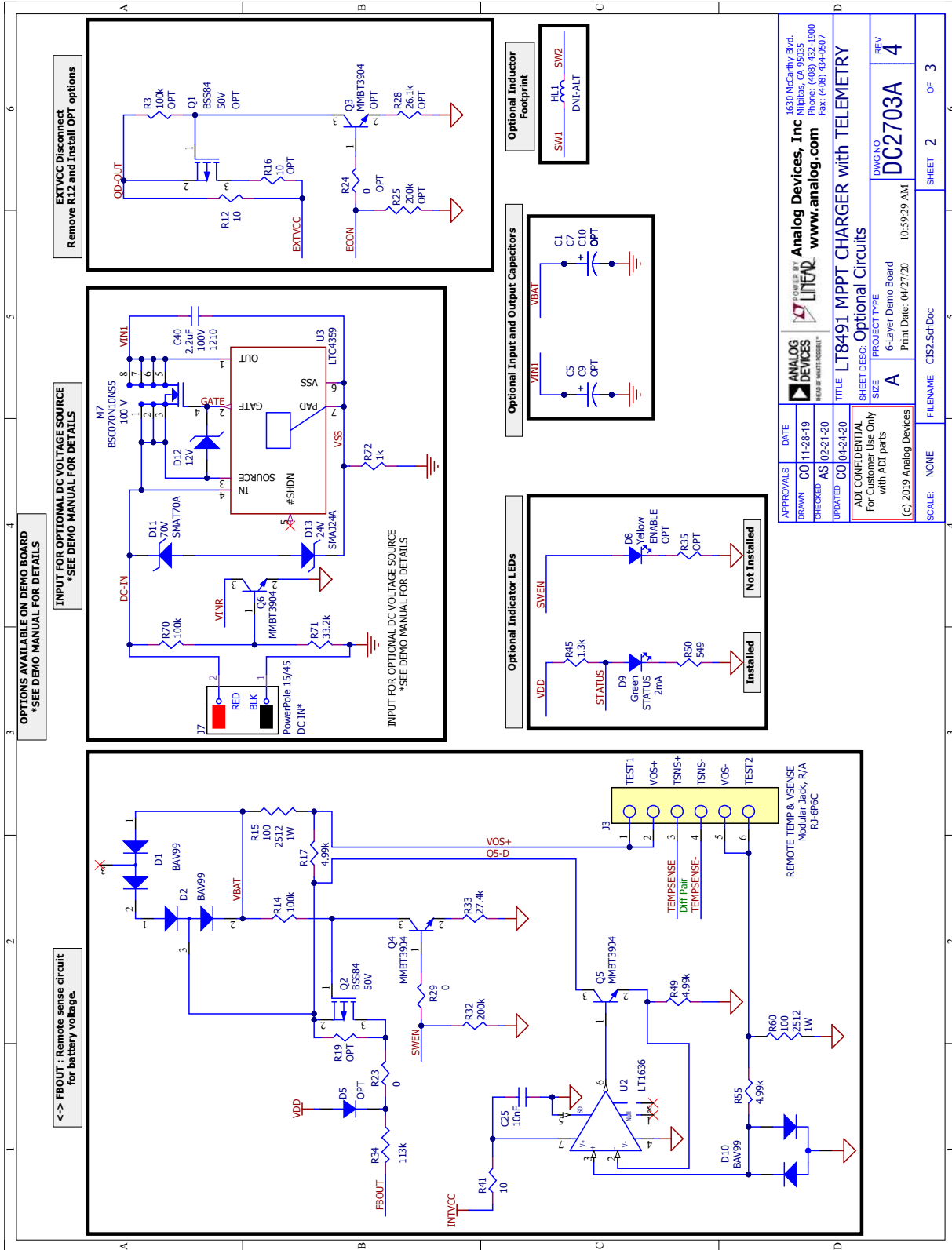

## SCHEMATIC DIAGRAM

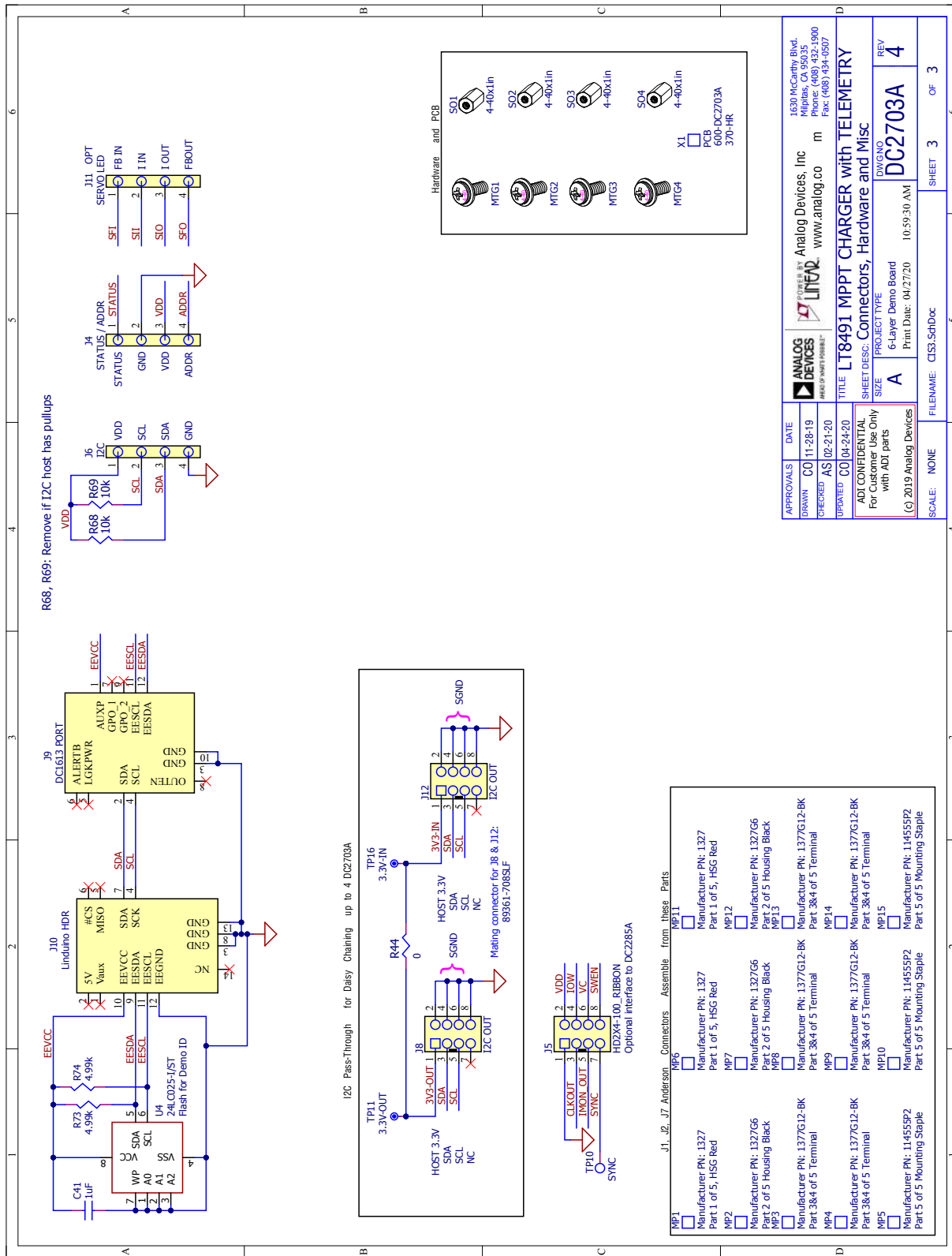

# DEMO MANUAL DC2703A-A-KIT

## BOARD PHOTO: TOP SIDE

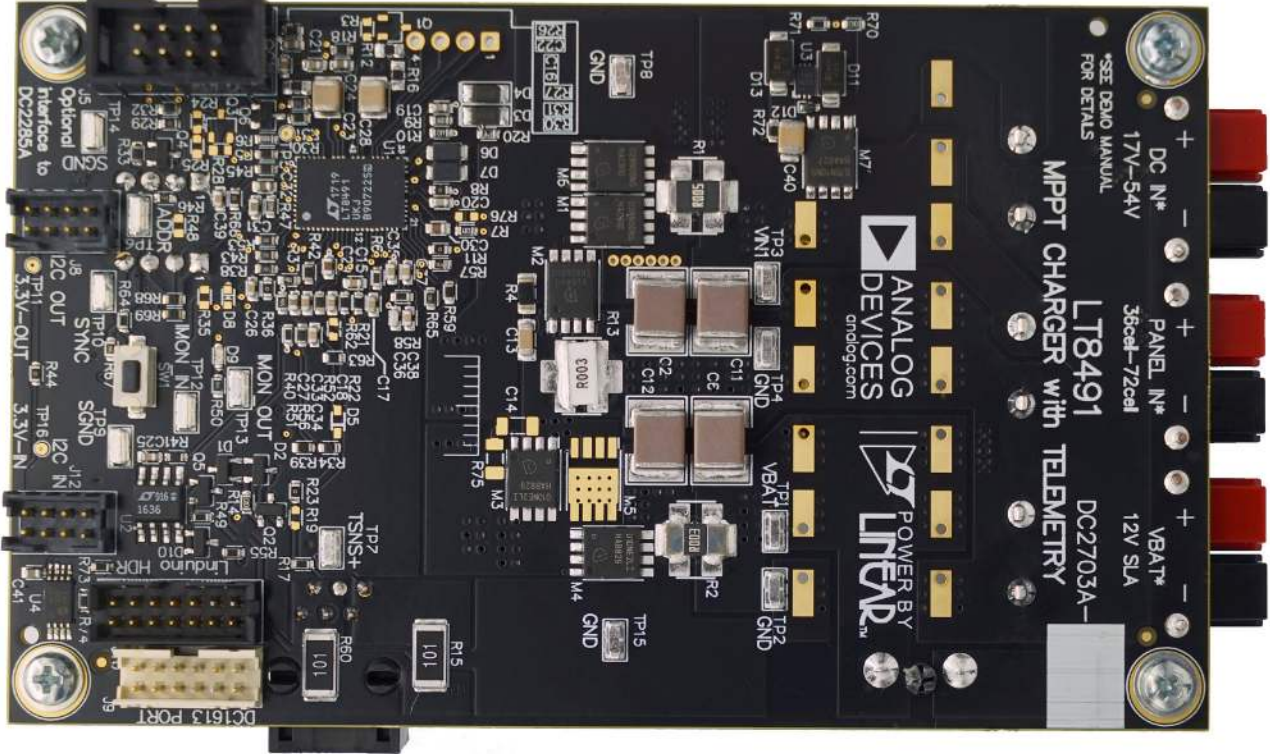

Figure 5. DC2703A-A-KIT Top Side

## BOARD PHOTO: BOTTOM SIDE

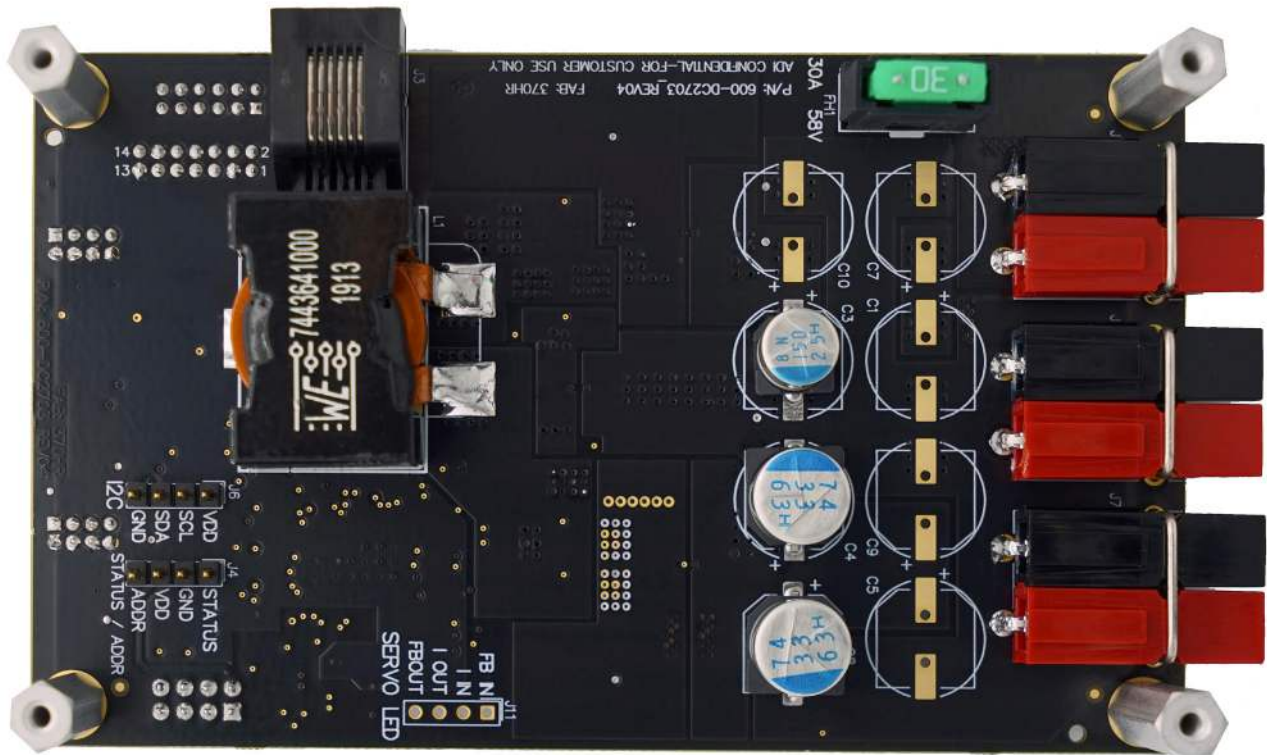

Figure 6. DC2703A-A-KIT Bottom Side



### ESD Caution

**ESD (electrostatic discharge) sensitive device.** Charged devices and circuit boards can discharge without detection. Although this product features patented or proprietary protection circuitry, damage may occur on devices subjected to high energy ESD. Therefore, proper ESD precautions should be taken to avoid performance degradation or loss of functionality.

### Legal Terms and Conditions

By using the evaluation board discussed herein (together with any tools, components documentation or support materials, the "Evaluation Board"), you are agreeing to be bound by the terms and conditions set forth below ("Agreement") unless you have purchased the Evaluation Board, in which case the Analog Devices Standard Terms and Conditions of Sale shall govern. Do not use the Evaluation Board until you have read and agreed to the Agreement. Your use of the Evaluation Board shall signify your acceptance of the Agreement. This Agreement is made by and between you ("Customer") and Analog Devices, Inc. ("ADI"), with its principal place of business at One Technology Way, Norwood, MA 02062, USA. Subject to the terms and conditions of the Agreement, ADI hereby grants to Customer a free, limited, personal, temporary, non-exclusive, non-sublicensable, non-transferable license to use the Evaluation Board FOR EVALUATION PURPOSES ONLY. Customer understands and agrees that the Evaluation Board is provided for the sole and exclusive purpose referenced above, and agrees not to use the Evaluation Board for any other purpose. Furthermore, the license granted is expressly made subject to the following additional limitations: Customer shall not (i) rent, lease, display, sell, transfer, assign, sublicense, or distribute the Evaluation Board; and (ii) permit any Third Party to access the Evaluation Board. As used herein, the term "Third Party" includes any entity other than ADI, Customer, their employees, affiliates and in-house consultants. The Evaluation Board is NOT sold to Customer; all rights not expressly granted herein, including ownership of the Evaluation Board, are reserved by ADI. CONFIDENTIALITY. This Agreement and the Evaluation Board shall all be considered the confidential and proprietary information of ADI. Customer may not disclose or transfer any portion of the Evaluation Board to any other party for any reason. Upon discontinuation of use of the Evaluation Board or termination of this Agreement, Customer agrees to promptly return the Evaluation Board to ADI. ADDITIONAL RESTRICTIONS. Customer may not disassemble, decompile or reverse engineer chips on the Evaluation Board. Customer shall inform ADI of any occurred damages or any modifications or alterations it makes to the Evaluation Board, including but not limited to soldering or any other activity that affects the material content of the Evaluation Board. Modifications to the Evaluation Board must comply with applicable law, including but not limited to the RoHS Directive. TERMINATION. ADI may terminate this Agreement at any time upon giving written notice to Customer. Customer agrees to return to ADI the Evaluation Board at that time. LIMITATION OF LIABILITY. THE EVALUATION BOARD PROVIDED HEREUNDER IS PROVIDED "AS IS" AND ADI MAKES NO WARRANTIES OR REPRESENTATIONS OF ANY KIND WITH RESPECT TO IT. ADI SPECIFICALLY DISCLAIMS ANY REPRESENTATIONS, ENDORSEMENTS, GUARANTEES, OR WARRANTIES, EXPRESS OR IMPLIED, RELATED TO THE EVALUATION BOARD INCLUDING, BUT NOT LIMITED TO, THE IMPLIED WARRANTY OF MERCHANTABILITY, TITLE, FITNESS FOR A PARTICULAR PURPOSE OR NON-INFRINGEMENT OF INTELLECTUAL PROPERTY RIGHTS. IN NO EVENT WILL ADI AND ITS LICENSORS BE LIABLE FOR ANY INCIDENTAL, SPECIAL, INDIRECT, OR CONSEQUENTIAL DAMAGES RESULTING FROM CUSTOMER'S POSSESSION OR USE OF THE EVALUATION BOARD, INCLUDING BUT NOT LIMITED TO LOST PROFITS, DELAY COSTS, LABOR COSTS OR LOSS OF GOODWILL. ADI'S TOTAL LIABILITY FROM ANY AND ALL CAUSES SHALL BE LIMITED TO THE AMOUNT OF ONE HUNDRED US DOLLARS (\$100.00). EXPORT. Customer agrees that it will not directly or indirectly export the Evaluation Board to another country, and that it will comply with all applicable United States federal laws and regulations relating to exports. GOVERNING LAW. This Agreement shall be governed by and construed in accordance with the substantive laws of the Commonwealth of Massachusetts (excluding conflict of law rules). Any legal action regarding this Agreement will be heard in the state or federal courts having jurisdiction in Suffolk County, Massachusetts, and Customer hereby submits to the personal jurisdiction and venue of such courts. The United Nations Convention on Contracts for the International Sale of Goods shall not apply to this Agreement and is expressly disclaimed.