



HARWIN

Component Specification

C00313

2.54mm Pitch Jumper Sockets
November 2022

SECTION	TITLE	PAGE
1	Description of Connector and Intended Application	2
2	Ratings	2
Appendix 1	Gauges	3



1. DESCRIPTION OF CONNECTOR AND INTENDED APPLICATION

A range of 2.54mm pitch jumper sockets, consisting of a moulded outer body holding phosphor bronze spring contacts. The contacts are either tin plated overall, or selectively gold plated on the contact area. The component is intended to interconnect two adjacent 0.64mm square or round section pins on 2.54mm pitch centres. Connectors can be mounted side by side in either direction on 2.54mm pitch centres. Double and single contact versions are available, with either open or closed tops on the single row versions.

2. RATINGS

2.1. Electrical Characteristics

Current (at ambient temperature):

M758X range.....1A max

Others.....3A max

Working Voltage (at sea level).....250V DC nominal or AC peak

Voltage Proof (at sea level):

M758X range.....500V AC

Others.....750V rms at 50Hz

Contact Resistance:

Initial.....20mΩ max

After conditioning30mΩ max Tin, 25mΩ max Gold

Insulation Resistance (measured between two pins not electrically connected):

M758X range.....5,000MΩ min

Others, initial.....100,000MΩ min

Others, hot after conditioning1,000MΩ min

2.2. Environmental Characteristics

Environmental Classification.....40/85/21

Low Air Pressure Severity300 mbar

Operating Temperature Range:

M758X range.....-55°C to +105°C

Others.....-40°C to +85°C

2.3. Mechanical Characteristics

Durability:

Gold on contact area300 mating operations

Tin on contact area.....50 mating operations

High Temperature, Long Term (current as in 2.1.)1,000 hours at 70°C

High Temperature, Short Term (no electrical load).....250 hours at 85°C

Contact Holding Force (with 0.64mm square pin).....100gram deadweight

Insertion force (0.64mm square pin):

M758X range.....13.7N max, 2.0N min

Others.....14.5N max, 5.0N min

Withdrawal force:

M758X range.....7.4N max, 1.0N min

Others.....5.0N max, 1.0N min



APPENDIX 1 – GAUGES

NOTES:

1. Material = Steel to BS1407 or equivalent.
2. Gauging surfaces to be hardened/ground, 650 HV5 min.
3. These gauges to be used for testing fully assembled components only.
4. Ultimate wear limit 0.005mm is allowable on gauging dimensions.

A1.1. Engaging and Separating Gauge

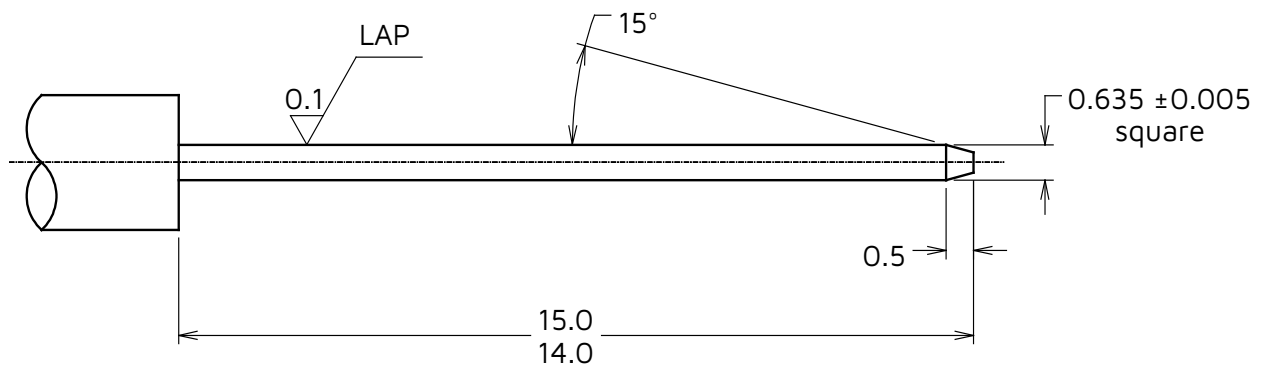

A1.2. Contact Push-out Gauge

