

APPROVAL SHEET

WLFM_C Multi-Layer Power Inductor

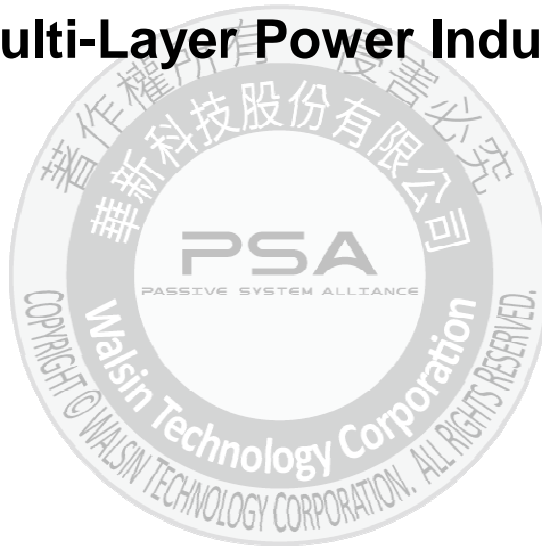

*Contents in this sheet are subject to change without prior notice.

Features

1. General purpose chip ferrite power inductor for high integration electronics device.
2. Ceramic structure provides high reliability · high productivity.
3. Low DC resistance with high current.
4. RoHS compliance.

Applications

1. DC line filter, DC/DC inductor.
2. Suitable for DVD,DSC,PND,PC,NB,Power Line.

Shape and Dimension

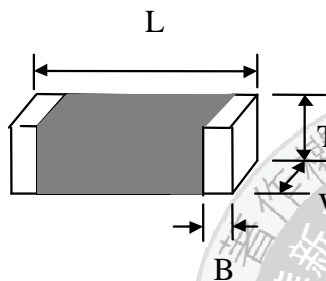

Unit: mm (inches)

WLFM Series	L	W	T	B (Min/Max)
WLFM201209	2.00±0.20	1.25±0.20	0.90±0.10	0.50±0.30
WLFM201609	2.00±0.20	1.60±0.20	0.90±0.10	0.50±0.30
WLFM252009	2.50±0.20	2.00±0.20	0.90±0.10	0.50±0.30

Ordering Information

WL	FM	2012	09	M	R47	P	C
Product Code WL: Inductor	Series Multilayer	Dimensions 2012:EIA 0805 2016:EIA 0806 2520:EIA 1008	Thickness 09= 0.9mm	Tolerance M: ± 20%	Value R47=0.47uH 2R2=2.2uH	Packing Code P=7" Reeled (Embossed tape)	C General

Electrical Characteristics

WLFM_C Series

Walsin Part Number	L(μH) Inductance	Tolerance	Test Freq (MHz)	RDC DC Resistance (Ω) Max.	Rated Current (mA)	SRF (MHz)
WLFM201209M1R0PC	1.00	±20%	1	0.10	1100	90
WLFM201209M2R2PC	2.20	±20%	1	0.17	900	70
WLFM201209M3R3PC	3.30	±20%	1	0.20	800	50
WLFM201209M4R7PC	4.70	±20%	1	0.23	800	40
Walsin Part Number	L(μH) Inductance	Tolerance	Test Freq (MHz)	RDC DC Resistance (Ω) Max.	Rated Current (mA)	SRF (MHz)
WLFM201609M2R2PC	2.20	±20%	1	0.12	1100	40
WLFM201609M4R7PC	4.70	±20%	1	0.16	900	20
Walsin Part Number	L(μH) Inductance	Tolerance	Test Freq (MHz)	RDC DC Resistance (Ω) Max.	Rated Current (mA)	SRF (MHz)
WLFM252009MR47PC	0.47	±20%	1	0.04	1800	100
WLFM252009M1R0PC	1.00	±20%	1	0.055	1600	60
WLFM252009M1R5PC	1.50	±20%	1	0.07	1500	50
WLFM252009M2R2PC	2.20	±20%	1	0.08	1300	40
WLFM252009M3R3PC	3.30	±20%	1	0.10	1200	30
WLFM252009M4R7PC	4.70	±20%	1	0.11	1100	25
WLFM252009M6R8PC	6.80	±20%	1	0.20	1100	25

*1 : For special part number which is not shown in the above table, please refer to appendix.

*2 : **Apply DC 0.4 ~ 0.6A to chip for 1 ~ 3 sec. before to measure inductance.**

Test Instrument :

- HP4291B-RF Impedance / Material Analyzer
- HP4338A/B Milliohm meter
- Test Frequency : 1MHz / OSC Level : 100mV

General Technical Data

Operating temperature range : - 40°C ~ +85°C
 Storage Condition : Less than 40°C and 70% RH
 Storage Time : 12 months Max.
 Soldering method : Reflow

Land Patterns for Reflow Soldering

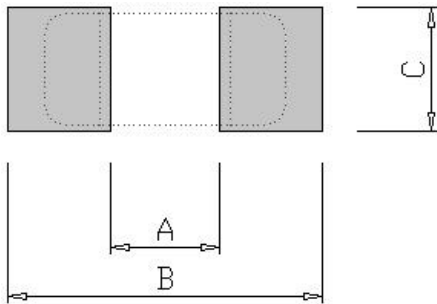

Size(mm)	A	B	C
2012	1.0 ~ 1.2	3.0 ~ 4.0	0.8 ~ 1.1
2016	1.0 ~ 1.2	3.0 ~ 4.0	1.0 ~ 1.5
2520	1.2~1.5	3.5~4.0	1.5~2.0

Reliability and Test Conditions

Test item	Test condition	Criteria
Resistance to Solder Heat	Solder temperature : $260 \pm 5^{\circ}\text{C}$ Flux : Rosin DIP time : 10 ± 1 sec	1. More than 95 % of terminal electrode should be covered with new solder 2. No mechanical damage 3. Inductance value should be within $\pm 20\%$ of the initial value * Apply DC 0.4 ~ 0.6A to chip for 1 ~ 3 sec. before to measure inductance.
Solderability	Solder temperature : $235 \pm 5^{\circ}\text{C}$ Flux : Rosin 3. DIP time : 5 ± 1 sec	1. More than 95 % of terminal electrode should be covered with new solder 2. No mechanical damage
Adhesive Test	Reflow temperature : 245°C It shall be Soldered on the substrate applying direction parallel to the substrate Apply force(F) : 5 N Test time : 10 sec	1. No mechanical damage 2. Soldering the products on PCB after the pulling test force > 5 N
Temperature Cycle	Temperature: $-40 \sim 85^{\circ}\text{C}$ For 30 minutes each Cycle: 100 cycles Measurement: At ambient temperature 24 hours after test completion	1. No mechanical damage 2. Inductance should be within $\pm 20\%$ of the initial value * Apply DC 0.4 ~ 0.6A to chip for 1 ~ 3 sec. before to measure inductance.
High Temperature Resistance	Temperature: $85 \pm 5^{\circ}\text{C}$ Testing time: 1000 hrs Measurement: at ambient temperature 24 hours after test completion	1. No mechanical damage 2. Inductance should be within $\pm 20\%$ of the initial value * Apply DC 0.4 ~ 0.6A to chip for 1 ~ 3 sec. before to measure inductance.
Humidity	Temperature: $40^{\circ}\text{C} \pm 2^{\circ}\text{C}$ Humidity: 90-95 % RH Testing time: 1000 hrs Measurement: At ambient temperature 24 hours after test completion	1. No mechanical damage 2. Inductance should be within $\pm 20\%$ of the initial value * Apply DC 0.4 ~ 0.6A to chip for 1 ~ 3 sec. before to measure inductance.
Rated Current	At ambient temperature & humidity Testing time: 5 minutes (under full rated current)	WLFM product surface temp .. below room temperature plus 40°C

Tape and Reel Specifications
Plastic Carries(E)

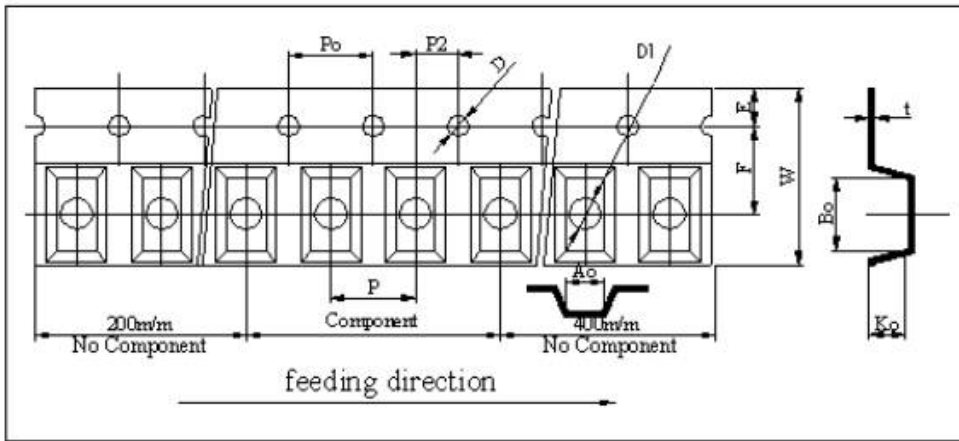

Paper Carrier(P)

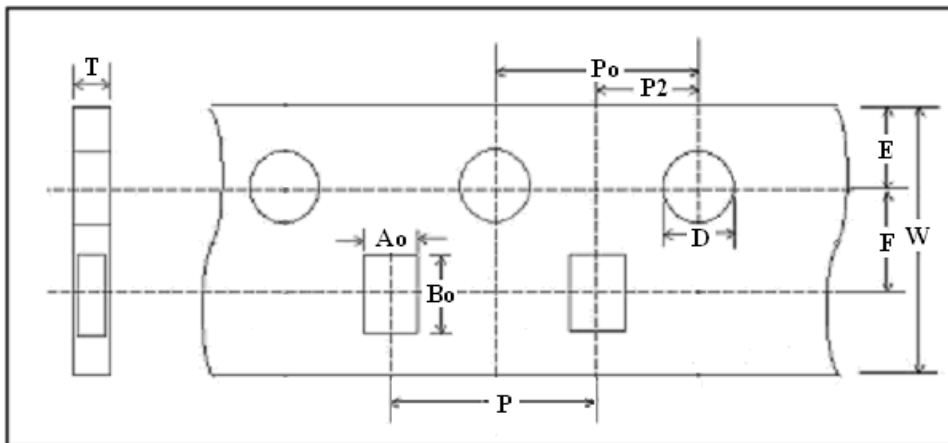

Taping Dimensions

(mm)	2012	2016	2520
Symbol	E	E	E
W	8.00 ± 0.10	8.00 ± 0.10	8.00 ± 0.10
P	4.00 ± 0.10	4.00 ± 0.10	4.00 ± 0.10
E	1.75 ± 0.10	1.75 ± 0.10	1.75 ± 0.10
F	3.50 ± 0.10	3.50 ± 0.10	3.50 ± 0.10
D	1.55 ± 0.05	1.55 ± 0.05	1.55 ± 0.05
D1	1.00 ± 0.05	1.00 ± 0.05	1.00 ± 0.05
Po	4.00 ± 0.10	4.00 ± 0.10	4.00 ± 0.10
10Po	40.0 ± 0.20	40.0 ± 0.20	40.0 ± 0.20
P2	2.00 ± 0.10	2.00 ± 0.10	2.00 ± 0.10
Ao	1.40 ± 0.10	1.80 ± 0.10	2.25 ± 0.10
Bo	2.30 ± 0.10	2.20 ± 0.10	2.80 ± 0.10
Ko(T)	1.13 ± 0.10	1.15 ± 0.10	1.35 ± 0.10
t	0.22 ± 0.05	0.22 ± 0.05	0.22 ± 0.05

Reel Dimensions

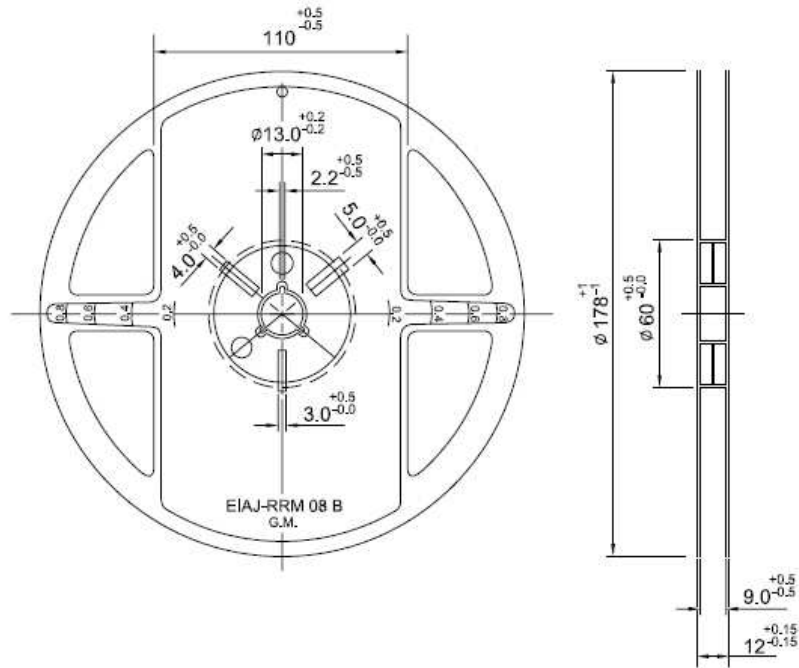

7" Reel Packaging Quantity			
PART SIZE (EIA SIZE)	2012 (0805)	2016 (0806)	2520 (1008)
Qty.(pcs)	3,000	3,000	3,000
BOX	5 reels / inner box	5 reels / inner box	5 reels / inner box

Recommended Soldering Conditions

