

SPECIFICATION FOR APPROVAL

CUSTOMER : _____

PRODUCT TYPE : SMD TCXO 7.0 * 5.0

NOMINAL FREQ. : 10.000000MHz

TXC P/N : 7N10071003

REVISION : S2

CUSTOMER P/N : _____

PM / SALES : _____

DATE : _____

CUSTOMER CONFIRMATION : _____
(Singnature)

_____ (Date)

- (1) TXC requires one copy returned with signature and title of authorized individual that signifies acceptance of the attached specifications.
- (2) Orders received and accepted by TXC after return of signed copy of specification will be produced per these specifications.
- (3) Any changes to these specifications must be agreed upon by both parties and new revision of the Product Specification Sheet will be issued.
- (4) Any issuance of purchase order prior to consigning back the Approval page of "Specification Sheets" from customers will be regarded as the agreement on the contents of these specifications.

MSL:Level 1
RoHS Compliant

(for glass crystal only : Pb used in sealing glass material is exempt from EU directive)

PRODUCT SPECIFICATION SHEET

PRODUCT TYPE : SMD TCXO 7.0 * 5.0

NOMINAL FREQ. : 10.000000MHz

TXC P/N : 7N10071003

REVISION : S2

PE/RD	QA	MFG
<i>Eric Tsao</i> Eric Tsao		
<i>30-Jun-21</i>		

NOTE:

- (1) If customer's application involves ultrasonic · molding · PCBA dicing and manual soldering processes or customer's products are used in automotive system, the applicability should be confirmed with TXC R&D responsible person.
- (2) The green product standard set by TXC is based upon the international standards. Related information is publicly described on the TXC's Website, and updated regularly. The document is compliant with the latest green product quality system directives at the time.
- (3) Revision "Sx" is for engineering samples only. PE/RD's approval required.
- (4) Revision "Ax" is production ready. PE, QA and MFG's approval required.

MSL:Level 1
RoHS Compliant

(for glass crystal only : Pb used in sealing glass material is exempt from EU directive)

<u>Rev</u>	<u>Revise page</u>	<u>Revise contents</u>	<u>Date</u>	<u>Ref.No.</u>	<u>Reviser</u>
S1	N/A	Initial released	2021/06/30	N/A	Tomy Teng
S2	N/A	MK code update	2022/12/27	N/A	Polly Li

ELECTRICAL SPECIFICATIONS

Item	Parameters		Condition	Electrical Specifications				Note
				MIN	TYP	MAX	UNITS	
1	Nominal Frequency			10.000000			MHz	
2	Operating Temperature Range			-40		+105	°C	
3	Storage Temperature			-55		+125	°C	
4	Supply Voltage			2.97	3.30	3.63	V	
5	Current Drain		With standard output load			6.0	mA	
6	Output Type			CMOS				
7	Output Load		Capacitance	13.5	15	16.5	pF	
8	Output Low					0.1*Vcc	V	
9	Output High			0.9*Vcc			V	
10	Enable Voltage High		Output Enabled	2.97			V	
11	Enable Voltage Low		Output Disable			0.33	V	
12	Rise Time		10% to 90% output swing			5	ns	
13	Fall Time		90% to 10% output swing			5	ns	
14	Duty Cycle			45	50	55	%	
15	Start-up Time	Output Level	To 90% of Vp-p			10	ms	
16	Initial Frequency Tolerance		25 °C ± 2 °C			±1.0	ppm	
17	Frequency Tolerance After Reflow		2 times			±1.0	ppm	1
18	Frequency Stability	vs. Temperature	-40 °C to +105 °C			±0.25	ppm	2
19		vs. Load	Standard output load ±10%			±0.1	ppm	3
20		vs. Supplu Voltage	Standard Vcc ± 10%			±0.1	ppm	4
21	Slope over Temperature (ΔF/ΔT)					±0.1	ppm/°C	
22	Holdover stability , constant temperature		24 hr			±50	ppb	5
22	Aging		1 years			±1.0	ppm	
23	Free-run Accurary		20years			±4.6	ppm	6
24	Phase Noise	@ 1 Hz offset				-72	dBc/Hz	
25		@ 10 Hz offset				-110	dBc/Hz	
26		@ 100 Hz offset				-135	dBc/Hz	
27		@ 1 kHz offset				-152	dBc/Hz	
28		@ 10 kHz offset				-158	dBc/Hz	
29		@ 100 kHz offset				-159	dBc/Hz	
30		@ 1 MHz offset				-160	dBc/Hz	
31	RMS Jitter		10Hz - 1MHz		0.9	1.8	ps	
32	Short Term Frequency Stability		Tau=1 sec			0.1	ppb/s	5
33	G-sensitivity		Gamma vector of all three axes from 30 Hz to 1500 Hz			2.0	ppb/g	

Note 1 Operation after reflow 2hrs, refer to nominal frequency

Note 2 Reference (Fmax + Fmin)/2

Note 3 Reference to frequency at 15 pF

Note 4 Reference to frequency at 3.3 V

Note 5 After 48hrs continuous operation and fix temperautre

Note 6 Inclusive of calibration tolerance at 25°C, frequency vs. change in temperature, change in supply voltage (±10%), load change (±10%), reflow soldering and 20 years aging.

TESTING CIRCUIT

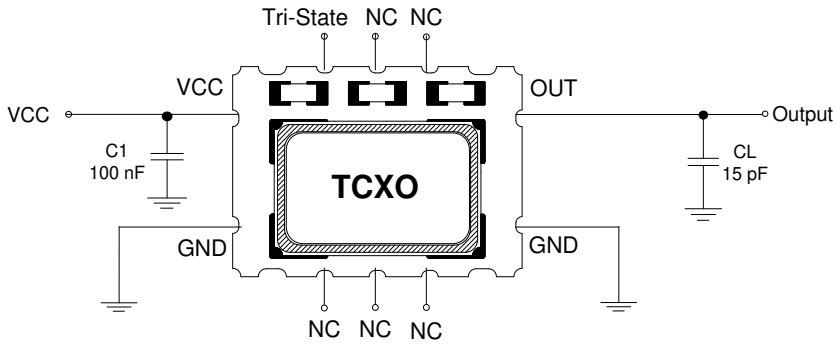

Note: Bypass capacitor (C1) should be placed.

External Components

Name	Function
C1	AC Noise Bypass for VCC
CL	Load Capacitance

DIMENSIONS

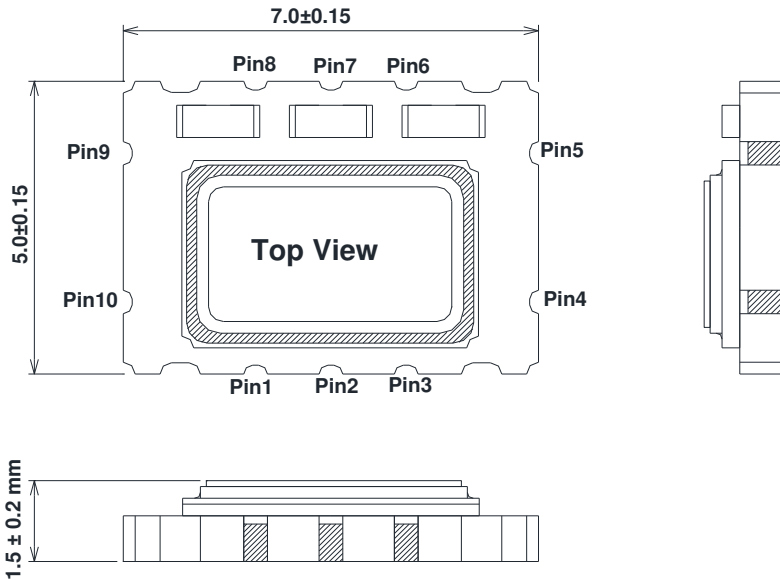

Pin Connection

Name	Function
Pin 1	NC
Pin 2	NC
Pin 3	NC
Pin 4	GND
Pin 5	Output
Pin 6	NC
Pin 7	NC
Pin 8	Tri-State
Pin 9	VCC
Pin 10	GND or NC

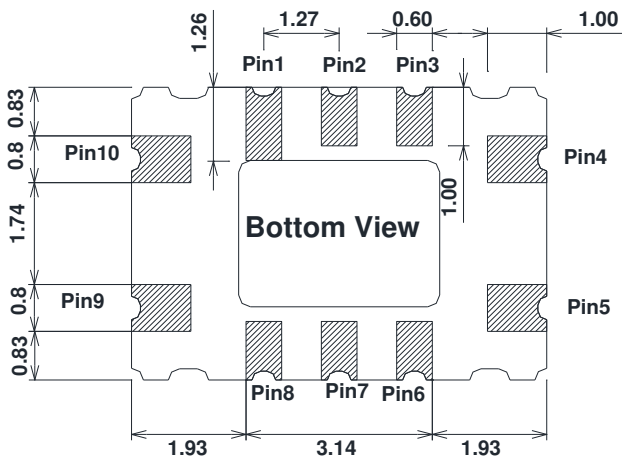

Recommended Land Pattern

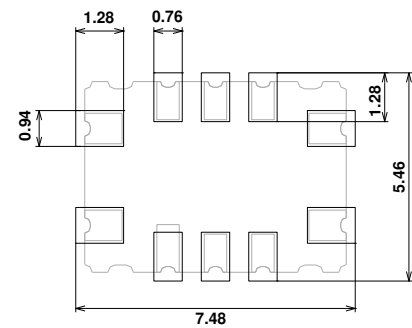

Unit : mm

■ SUGGESTED REFLOW PROFILE

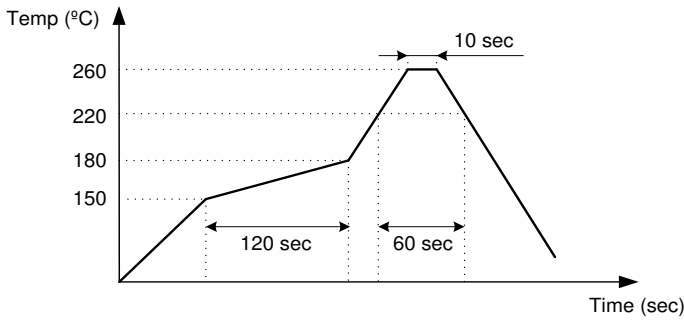

Note 1: Period while temperature exceeds the solder melting point : 220°C should be less than 200 sec.

Note 2: Period while temperature stays at the top melting point : 260°C should be less than 30 sec.

■ MARKING

No Divide Mode :

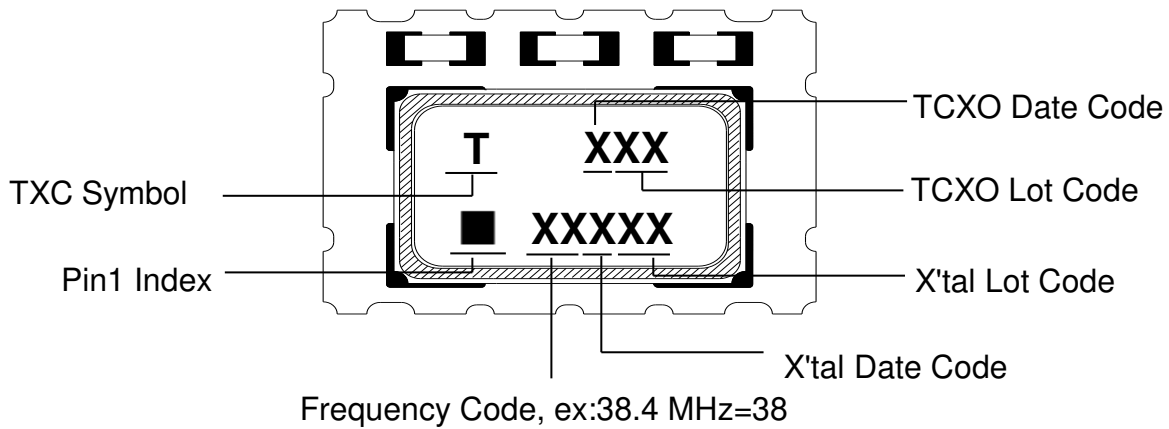

Divide Mode :

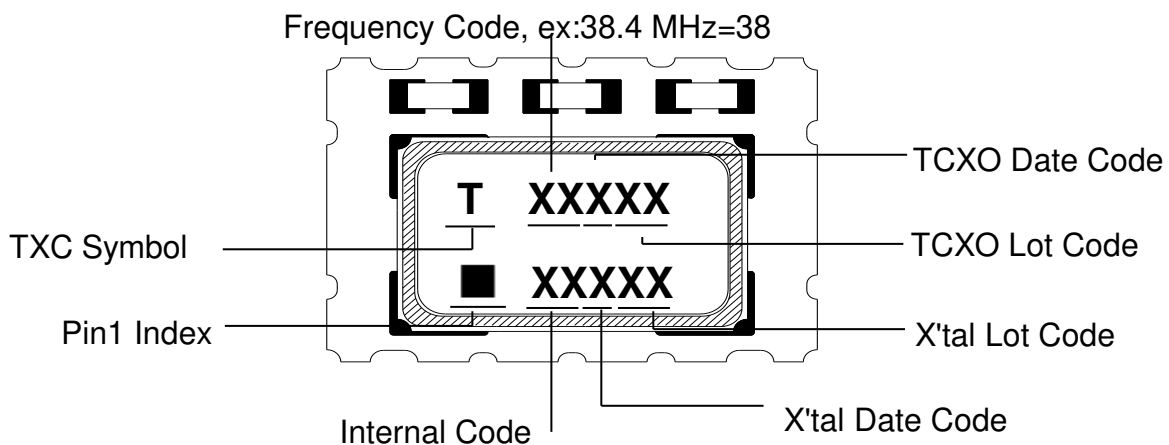

YEAR					MONTH											
					JAN	FEB	MAR	APR	MAY	JUN	JUL	AUG	SEP	OCT	NOV	DEC
2021	2025	2029	2033	2037	A	B	C	D	E	F	G	H	J	K	L	M
2022	2026	2030	2034	2038	N	P	Q	R	S	T	U	V	W	X	Y	Z
2023	2027	2031	2035	2039	a	b	c	d	e	f	g	h	j	k	l	m
2024	2028	2032	2036	2040	n	p	q	r	s	t	u	v	w	x	y	z

* This date code will be cycled every four years.

■ **PACKING : (EIA-481-2)**

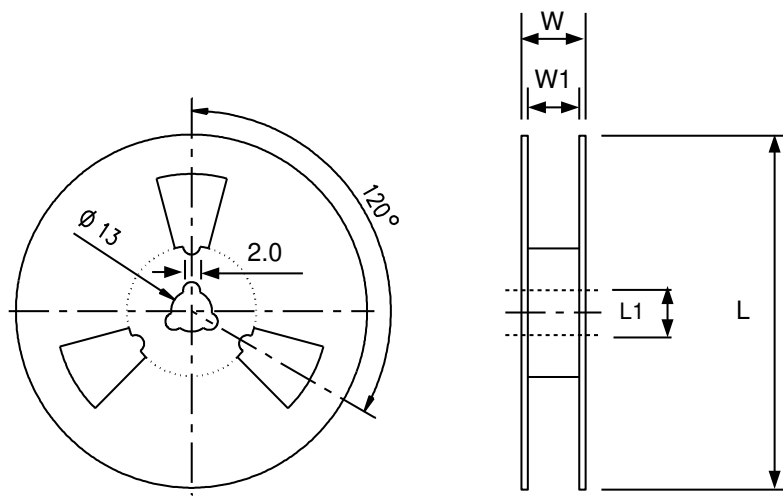
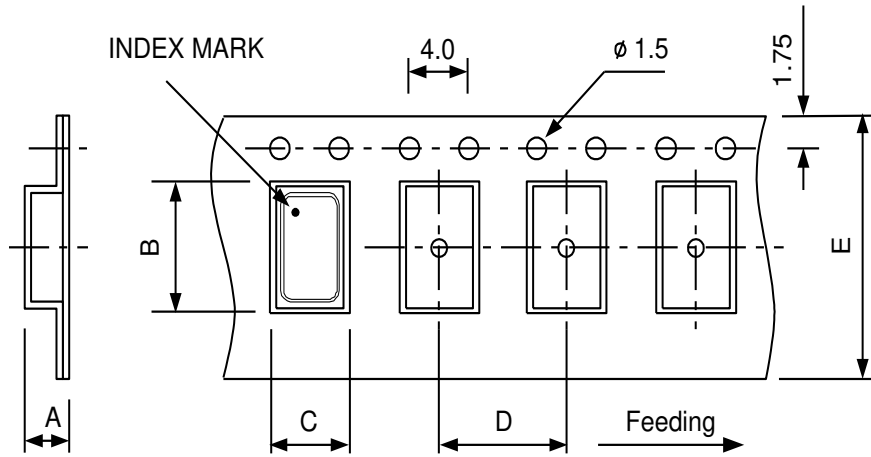

Unit: mm

DIMENSIONS (mm)	A	B	C	D	E	L	L1	W	W1	Standard Reel Quantity is 1,000 pcs per reel
	2.00	7.90	5.45	8.00	16.00	180	13.0	20.5	16.0	

■ **WEIGHT**

0.137 g / piece(TYP) , 137±5 g / 1 kpcs(regardless of tape weight)

STRUCTURE ILLUSTRATION

Crystal Enclosure Seal:

Seam Welding

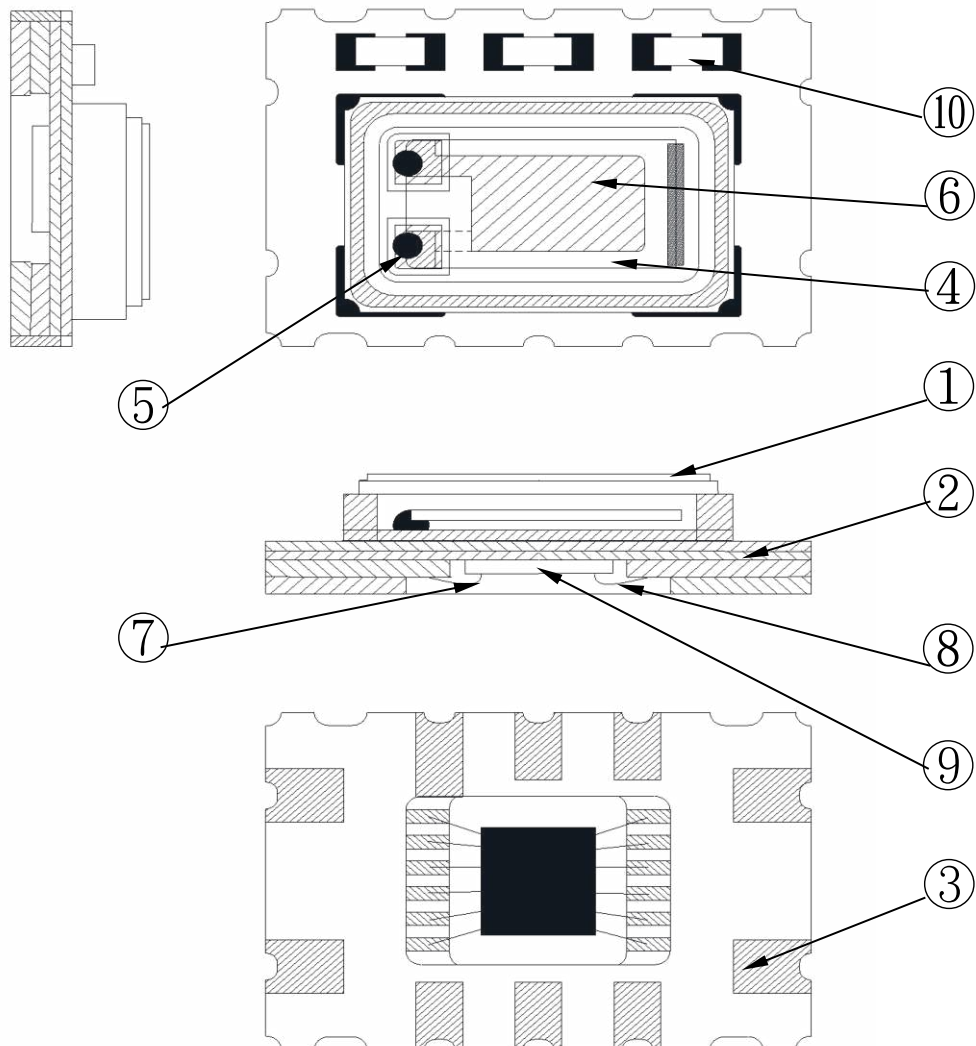

No.	COMPONENTS	MATERIALS	FINISH/SPECIFICATIONS
1	Cap	Metal(Fe + Co + Ni)	-
2	Base	Ceramic	Color Black
3	Pad	Au	Tungsten Metalize + Ni Plating + Au Plating
4	Crystal Blank	SiO ₂	-
5	Conductive Adhesive	Ag	Silicone Resin
6	Electrode	Noble Metal	-
7	Underfill	Organic	Color Black
8	Bonding Wire	Au	
9	IC	Si	
10	Capacitor	Ceramic	

■ RELIABILITY SPECIFICATIONS

1. Mechanical Endurance

No.	Test Item	Test Methods	Standard
1.1	Drop Test	Height : 75 cm height Test cycles : 3 cycles Fall freely on to wood floor	IEC-68-02-27
1.2	Mechanical Shock	Acceleration : 1000 g Duration : 0.5 ms Test cycles : 3 times for all 3 directions	MIL-STD-202 Method 213B
1.3	Vibration	Acceleration : 20 g Duration : 4 hours/each direction Frequency range : 10 ~ 2000 Hz Amplitude : 1.52 mm Direction : X,Y,Z 3 directions Sweep speed : 20 minutes/cycle	MIL-STD-883 Method 2007.3
1.4	Solderability	Preheat temperature : $125^{\circ}\text{C} \pm 5^{\circ}\text{C}$ Preheat time : 120 sec Soldering temperature : $245^{\circ}\text{C} \pm 5^{\circ}\text{C}$ Duration : 5 ± 1 sec Method : Solder bath method Criterion : >90% Coated	J-STD-002

2. Environmental Endurance

No.	Test Item	Test Methods	Standard
2.1	High Temp. Storage	Temperature : $+125^{\circ}\text{C} \pm 3^{\circ}\text{C}$ Duration : 1000 hours	MIL-STD-883 Method 1005.8
2.2	Low Temp. Storage	Temperature : $-40^{\circ}\text{C} \pm 3^{\circ}\text{C}$ Duration : 1000 hours	MIL-STD-883 Method 1013
2.3	Thermal Shock (Air to Air)	$-55^{\circ}\text{C} \sim 125^{\circ}\text{C}$, Dwell: 15min, Maximum transfer time 20sec, 500 cycles	MIL-STD-202
2.4	High Temp & Humidity	Temperature : $85^{\circ}\text{C} \pm 3^{\circ}\text{C}$ Humidity: RH 85% Duration : 1000 hours	EIA-JESD22-A101-B
2.5	Aging	Temperature : $85^{\circ}\text{C} \pm 3^{\circ}\text{C}$ Duration : 1000 hours Voltage input by specification	JIS C6701
2.6	ESD	HBM : 2000 V	JESD22-A114-B
		CDM : 500 V	JESD22-C101-B
		MM : 200 V	JESD22-A115-B

[Note] This product is Level 1 for JEDEC J-STD-020D moisture sensitivity level.