

REVISIONS			
REV	DESCRIPTION	DATE	APPROVAL
B	REVISE AND REDRAW	7-11-89	96073 KDB
C	ADD P/N 5VA-12050-0N TO TAB	7-28-89	98089 RJM
D	ADD P/N 5VA-12050-0P TO TAB	10-24-91	91030 JL
E	CHANGE PWB ASSY PART NO	7-21-94	46033 JL
F	REMOVE P/N 5VA-12050-0N FROM CHART	7-21-99	96531
G	CHANGE 5VA1205000 BASE MKG P/N	8-29-01	16542

NOTES:

1. NOT ALL COMPONENTS SHOWN ON CIRCUIT BOARD ASSEMBLY FOR CLARITY.
2. HOT MELT PWB TO BASE AND CAP AND TUBE TO PWB.
3. HOT MELT POTS AFTER SETTING AT PRETEST.

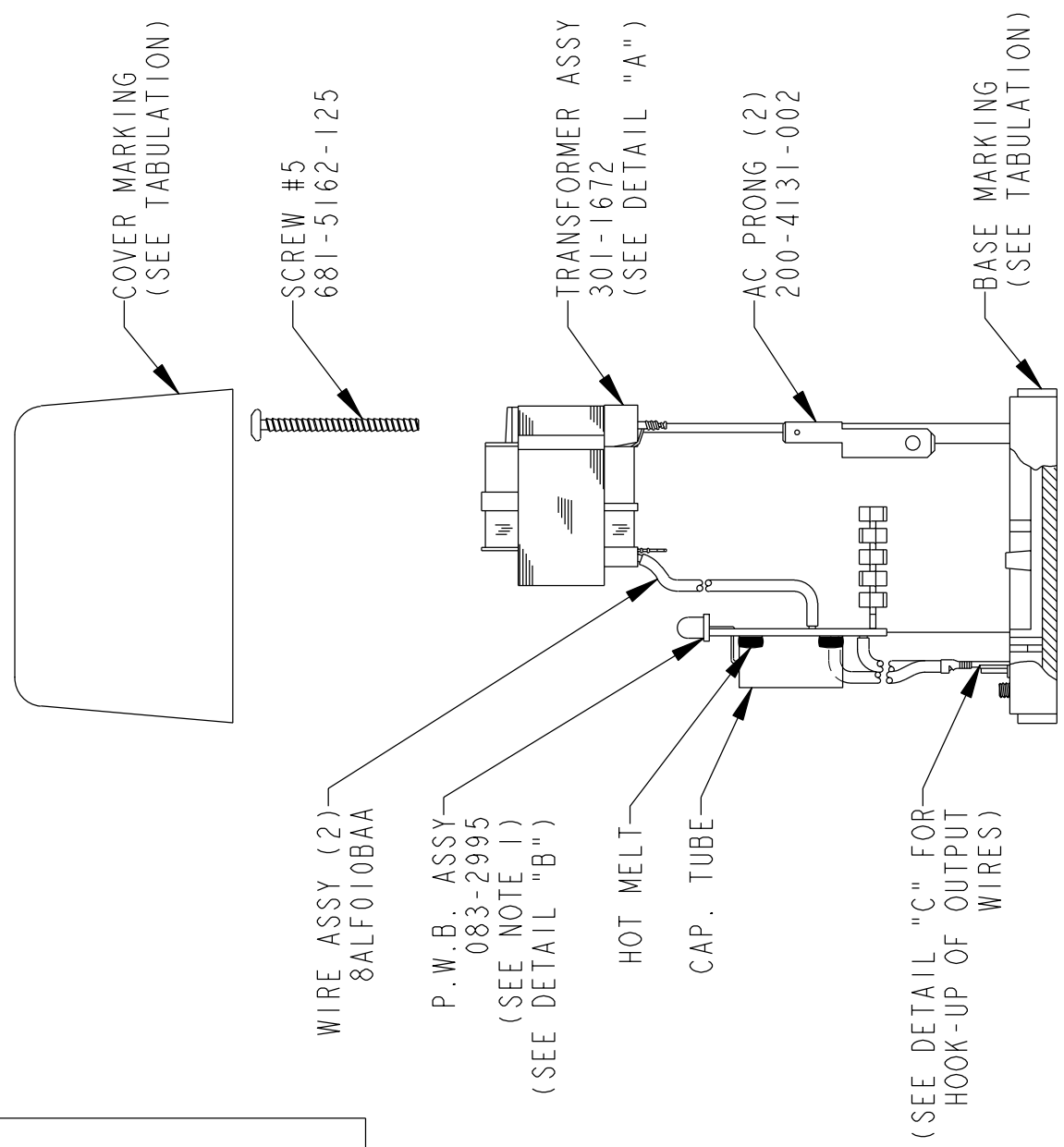

DETAIL "A"

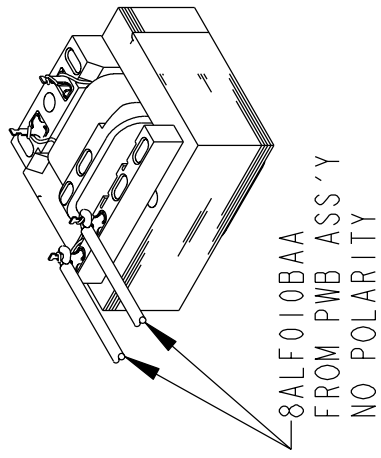

DETAIL "B"

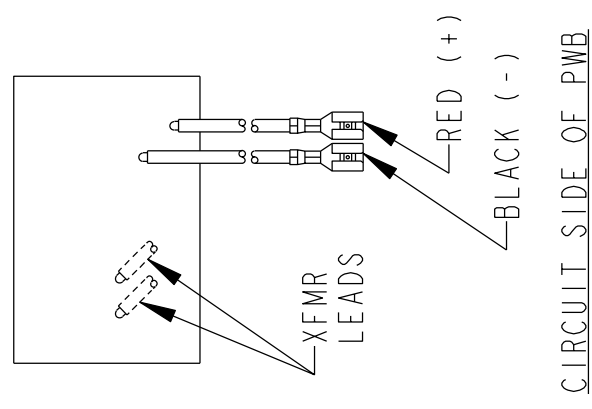

CIRCUIT SIDE OF PWB

DETAIL "C"

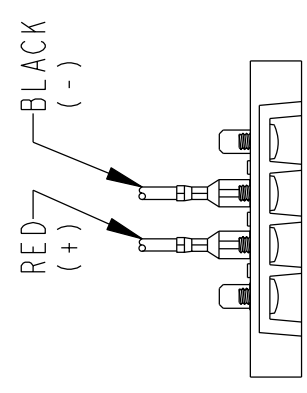

VIEW OF BASE AND LEADWIRE HOOK-UP ONLY

UNIT	PART NO	REV	BASE ASSY	COVER MARKING
5VA-12050-00	J	J	170-2071	150-1368
5VA-12050-02	J	J	150-1558	170-1974
5VA-12050-07	H	H	150-1370	150-1368
5VA-12050-0P	B	B	150-4580	150-4587

SUPPLEMENTARY INFORMATION FIRST USED

DO NOT SCALE DRAWING	
DRAWN BY	M. HOVDE 29-Aug-01
DESIGNER	
AGENCY	
ENGINEER	
APPROVED	RJM 4-22-85

TOLERANCES UNLESS NOTED OTHERWISE

.X	±.020
.XX	±.010
.XXX	±.005
ANGLES	±.5°

BATTERY CHARGER FINAL ASSEMBLY

SIZE	DRAWING NO.	REV
B	5VA120500X	G
SCALE		NONE
SHEET		1 OF 1

