

THIS DRAWING IS UNPUBLISHED. RELEASED FOR PUBLICATION
 © COPYRIGHT - By - ALL RIGHTS RESERVED.

LOC		DIST		REVISIONS			
P	LTR	DESCRIPTION		DATE	DWN	APVD	
AF	50	H1	REVISED PER ECR-19-013909	01OCT2019	PC	MB	

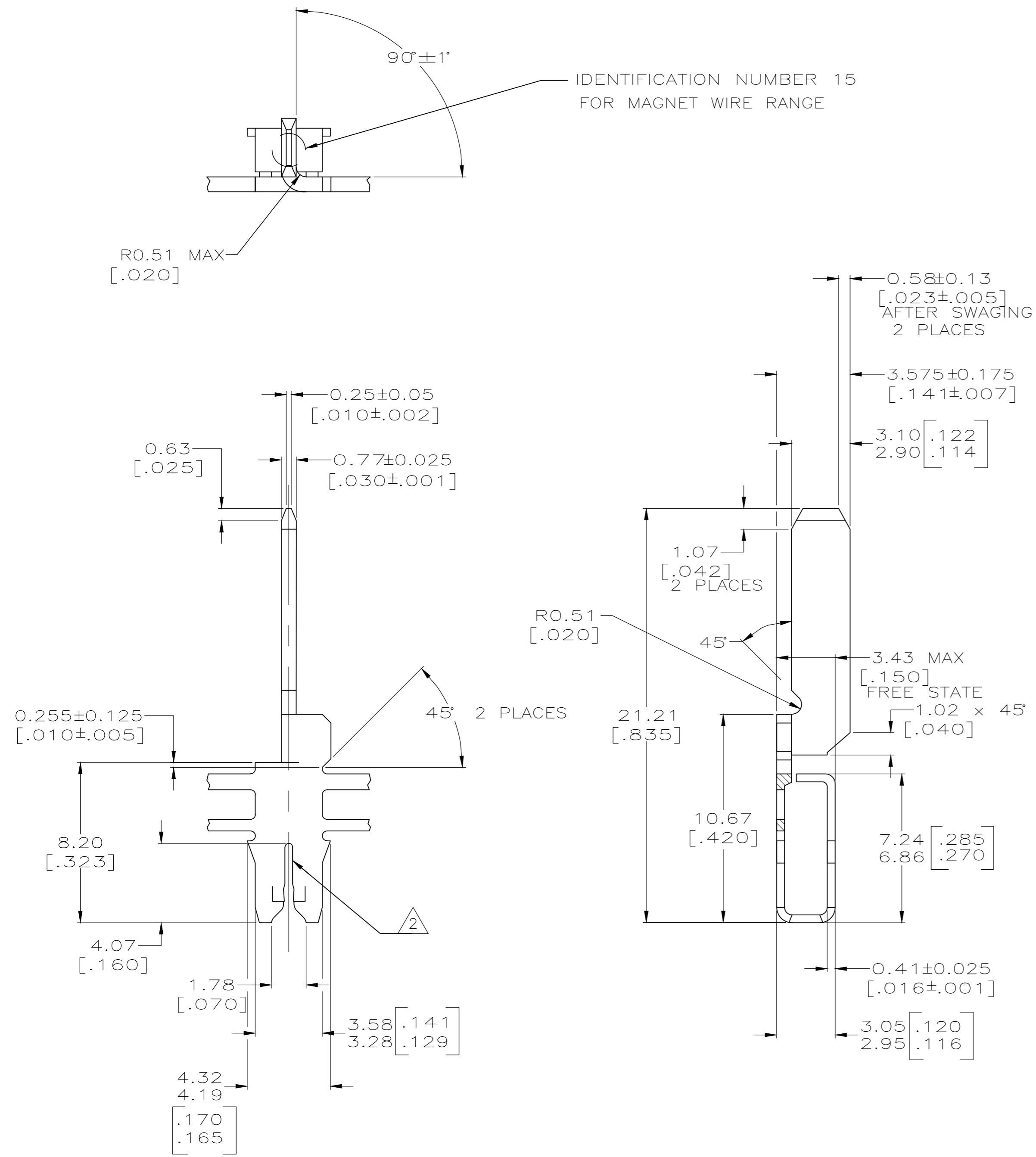

- 1 CONTINUOUS STRIP ON REELS WITH TERMINALS LOCATED ON 8.38 ± 0.076 [.330 ± .003] CENTERS
- 2 SLOT ACCEPTS 0.72mm DIA [#21] AWG COPPER MAGNET WIRE. COPPER RANGE #22-#20 AWG. ALUMINIUM RANGE #21-#19 AWG, ALUMINIUM WIRE RANGE APPLIES FOR POST TIN PLATED PART NUMBERS ONLY.
- 3 REFER TO DWG 87-1039-3 FOR ADDITIONAL CAVITY INFORMATION (MODIFIED DEPTH)
- 4 PRELIMINARY - NOT FOR PRODUCTION.
- 5 TIN PLATED
- 6 TIN PLATE OVER NICKEL PLATE

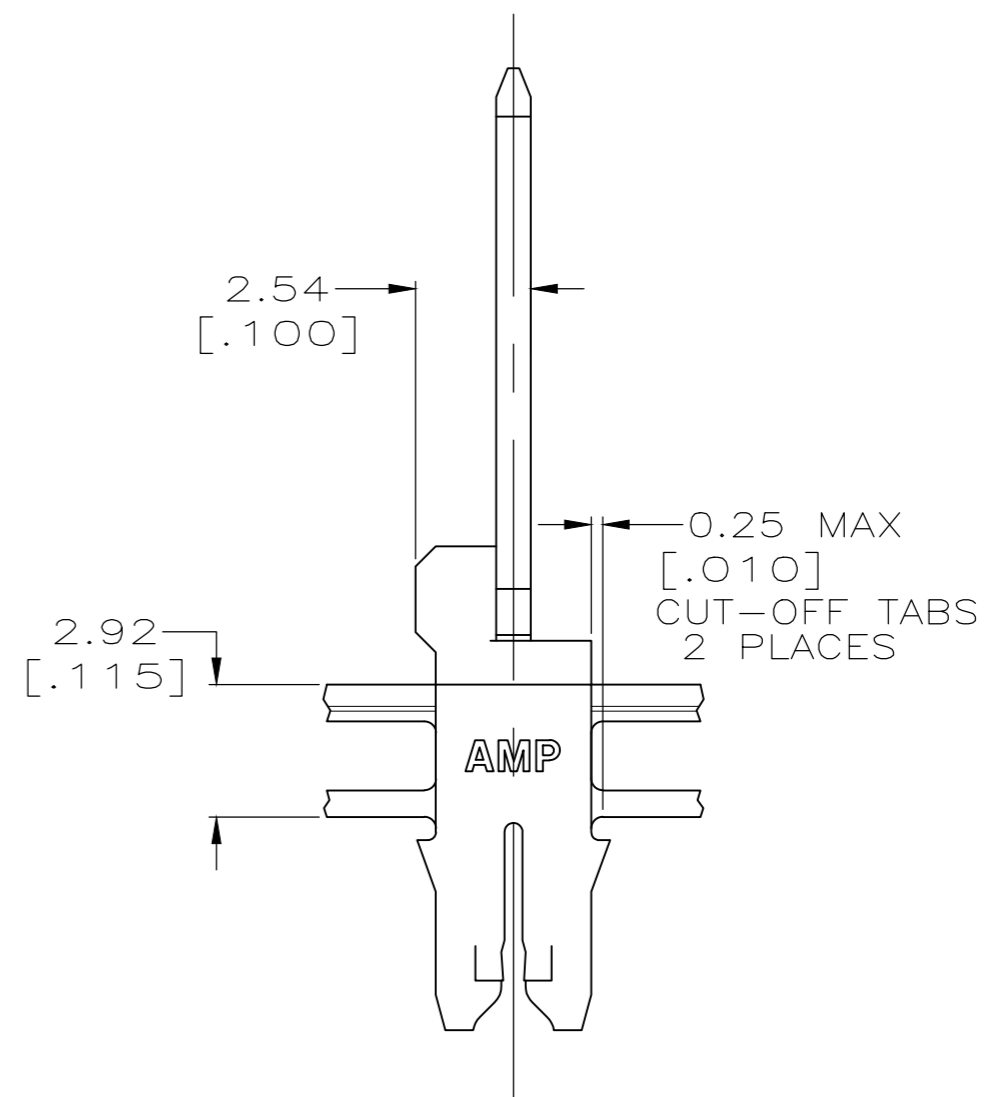

OBSOLETE	6	WELD	4	63463-3
OBSOLETE	5	SPLICE FREE	4	63463-2
	5	PAPER		63641-1
		FINISH	SPLICE	PART NUMBER

THIS DRAWING IS A CONTROLLED DOCUMENT.		DWN	R.GRZYBOWSKI	24JUN97	TE Connectivity	
DIMENSIONS: mm		CHK	M.S.FEHER	24JUN97	TAB, 3.00 [.118] CONNECTING, MAG-MATE	
TOLERANCES UNLESS OTHERWISE SPECIFIED:		APVD	N.E.NEFF	24JUN97	-	
0 PLC	± -	PRODUCT SPEC	108-2012	SIZE	CAGE CODE	DRAWING NO
1 PLC	± -	APPLICATION SPEC	114-2046	A2	00779	C=63463
2 PLC	± 0.25 [.010]			SCALE	SHEET	REV
3 PLC	± -			6:1	1 of 1	H1
4 PLC	± -					
ANGLES	± -					
MATERIAL	FINISH	WEIGHT				
BRASS	SEE TABLE					
CUSTOMER DRAWING						