

- 1. COORDINATE DIMENSION APPLIES FROM BASIC LOCATION.
- 2. 10 AND 14 POSITION SIZES CONTAIN ONLY ONE SLOT FOR SNAP-IN POLARIZER (MILITARY POLARIZATION) LOCATED AS SHOWN.
- 3. 10 POSITION SIZES CONTAIN ONLY ONE SLOT FOR DUAL POLARIZATION, LOCATED AS SHOWN.
- 4. RECOMMENDED PRINTED CIRCUIT BOARD THICKNESS IS 1.57 [.062].
- 5. DISTANCE REQUIRED BY EJECTION LATCHES IN THE OPEN POSITION.
- 6. HOUSING & LATCHES: GLASS FILLED NYLON OR POLYESTER, UL94V-0 RATED, BLACK. POSTS: PHOS BRONZE OR BRASS.
- 7. POSTS:  
 GOLD FLASH OVER PALLADIUM-NICKEL PLATE, 0.38µm [.000015] MIN TOTAL ON THE LOCALIZED PLATE AREA,  
 2.54µm [.000100] MIN TIN PLATE ON THE SOLDER-TAIL,  
 1.27µm [.000050] MIN NICKEL UNDERPLATE ON THE ENTIRE POST.  
 OR  
 0.38µm [.000015] MIN GOLD PLATE ON THE LOCALIZED PLATE AREA,  
 2.54µm [.000100] MIN TIN PLATE ON THE SOLDER-TAIL,  
 1.27µm [.000050] MIN NICKEL UNDERPLATE ON THE ENTIRE POST.
- 8. DATUMS -M- & -N- TO BE ESTABLISHED BY CUSTOMER.

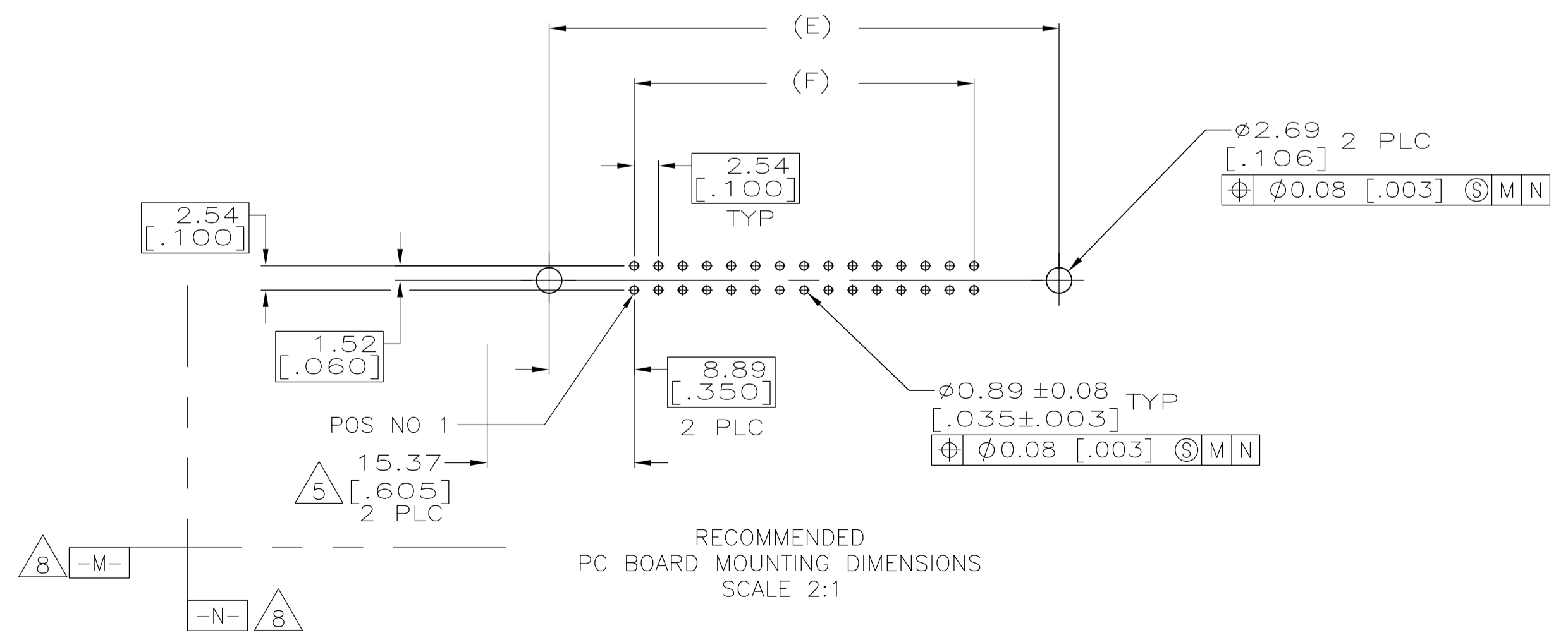
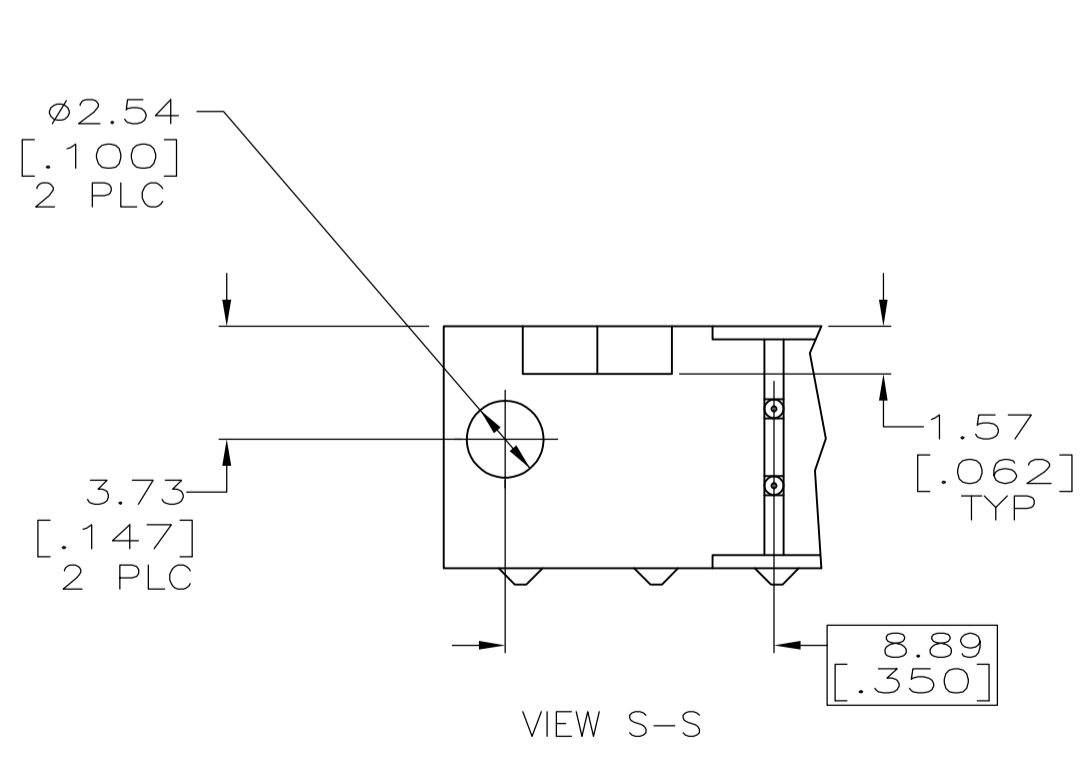
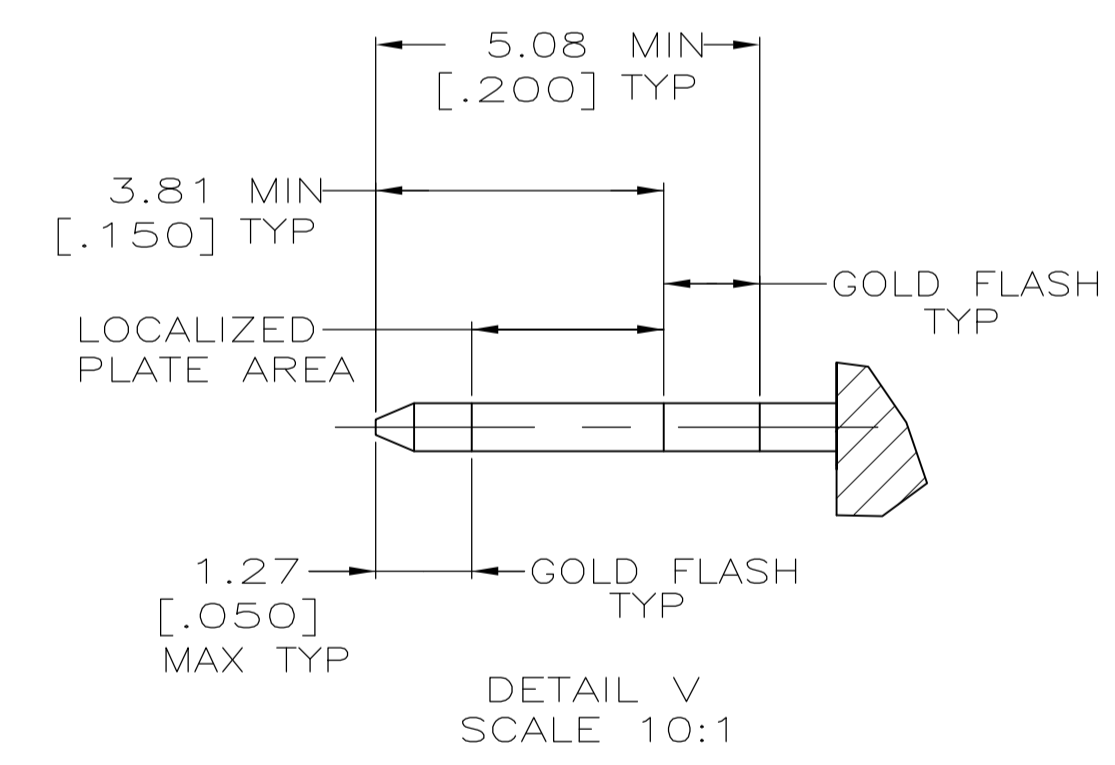
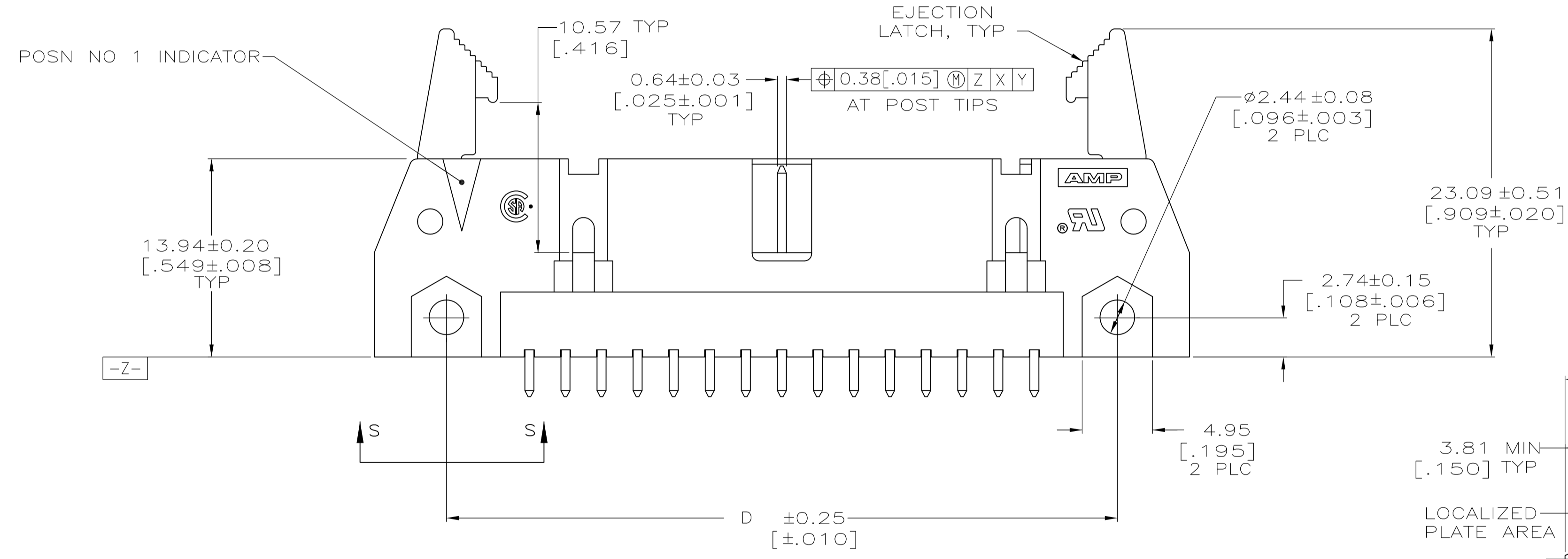

OBSOLETE	78.74	96.52	90.42	100.58	96.52	86.36	64	1-5499910-2
	[3.100]	[3.800]	[3.560]	[3.960]	[3.800]	[3.400]		
OBSOLETE	73.66	91.44	85.34	95.50	91.44	81.28	60	1-5499910-1
	[2.900]	[3.600]	[3.360]	[3.760]	[3.600]	[3.200]		
	60.96	78.74	72.64	82.80	78.74	68.58	50	1-5499910-0
	[2.400]	[3.100]	[2.860]	[3.260]	[3.100]	[2.700]		
	48.26	66.04	59.94	70.10	66.04	55.88	40	5499910-9
	[1.900]	[2.600]	[2.360]	[2.760]	[2.600]	[2.200]		
	40.64	58.42	52.32	62.48	58.42	48.26	34	5499910-8
	[1.600]	[2.300]	[2.060]	[2.460]	[2.300]	[1.900]		
	35.56	53.34	47.24	57.40	53.34	43.18	30	5499910-7
	[1.400]	[2.100]	[1.860]	[2.260]	[2.100]	[1.700]		
	30.48	48.26	42.16	52.32	48.26	38.10	26	5499910-6
	[1.200]	[1.900]	[1.660]	[2.060]	[1.900]	[1.500]		
	27.94	45.72	39.62	49.78	45.72	35.56	24	5499910-5
	[1.100]	[1.800]	[1.560]	[1.960]	[1.800]	[1.400]		
	22.86	40.64	34.54	44.70	40.64	30.48	20	5499910-4
	[.900]	[1.600]	[1.360]	[1.760]	[1.600]	[1.200]		
	17.78	35.56	29.46	39.62	35.56	25.40	16	5499910-3
	[.700]	[1.400]	[1.160]	[1.560]	[1.400]	[1.000]		
	15.24	33.02	26.92	37.08	33.02	22.86	14	5499910-2
	[.600]	[1.300]	[1.060]	[1.460]	[1.300]	[.900]		
	10.16	27.94	21.84	32.00	27.94	17.78	10	5499910-1
	[.400]	[1.100]	[.860]	[1.260]	[1.100]	[.700]		
	F	E	D	C	B	A	NO OF POSN	PART NUMBER

THIS DRAWING IS A CONTROLLED DOCUMENT.

DIMENSIONS: mm (INCHES)

TOLERANCES UNLESS OTHERWISE SPECIFIED:

0 PLC	±	-
1 PLC	±	-
2 PLC	±	0.13[.005]
3 PLC	±	-
4 PLC	±	-
ANGLES	±	-

MATERIAL: 6 FINISH: 7

APPROVED: L. VARELA - DOCKS 01-11-05  
S. BOLASH 01-11-05  
M. WALMSLEY 01-11-05

NAME: HEADER ASSY, UNIVERSAL, AMP-LATCH

PRODUCT SPEC: 108-40018

APPLICATION SPEC: -

SIZE: A1 CASE CODE: 00779 DRAWING NO: 5499910

RESTRICTED TO: -

CUSTOMER DRAWING SCALE: 4:1 SHEET: 1 OF 1 REV: C1