

A-MP* MINIATURE COAXICON* CONTACT CRIMPING DIES

FOR USE IN PNEUMATIC TOOLS NO. 69365† AND
69365-2 OR HAND TOOL NO. 69710

IS 1770-3

RELEASED 8-30-71

REVISED

MINIATURE CONTACT CRIMPING DIES		
69220-2	69315-4	69675
69222-2	69373	69675-1
69227-2	69440	
69230-1	69672	

1. A-MP Miniature COAXICON Contact Crimping Dies can be used in any of the tools listed above. First read instructions shipped with tools for information concerning Die Insertion, Crimping Procedure and General Tool Performance. Then refer to selection charts on AMP Instruction Sheet IS 1770 for proper Contacts and Cables to use. IS 1770 also contains information concerning Cable Stripping Lengths and assembly of contacts for crimping.

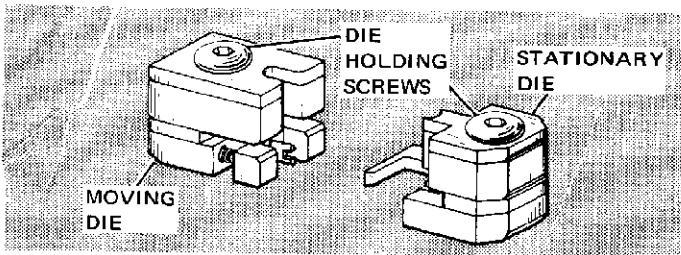

Figure 1

2. CRIMPING PROCEDURE

- (a) Place Crimping Dies in Tool.
- (b) Most Die Assemblies have three sets of Crimping Dies - one for Inner Wire Barrel of Contact, one for Braid Section of Ferrule and another for Outer Insulation Section of Ferrule. See Figure 2. All three crimps are made at the same time.
- (c) Place Contact in Upper Crimping Die as shown in Figure 3.
- (d) Line up Crimping Ports with Barrel Crimping Dies.
- (e) Push Contact "up" so that Upper Barrel Crimping Die enters Crimping Port and Ferrule bottoms against Braid-Ferrule Crimping Die. See Figure 3.
- (f) Make sure that Lower Barrel-Crimping Die is lined up with Crimping Port.

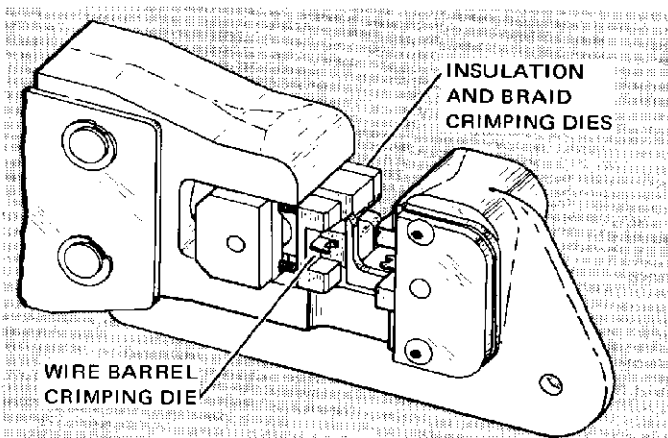

Figure 2

MAKE SURE THAT LOWER WIRE-BARREL CRIMPING DIE IS LINED UP WITH OTHER CRIMPING PORT BEFORE CLOSING TOOL HANDLES ALL THE WAY OR APPLYING POWER.

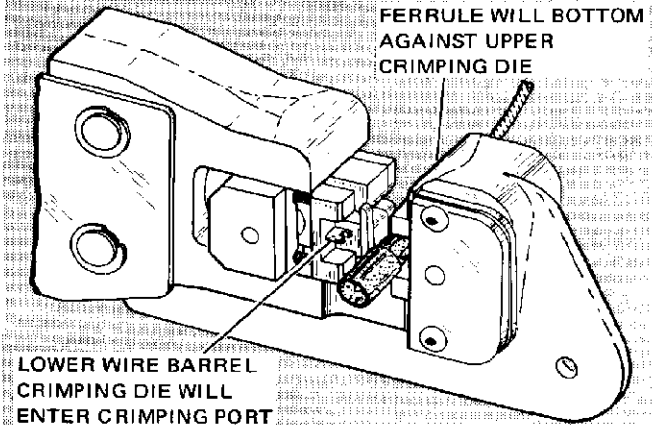

Figure 3

- (g) If Hand Tool No. 69710 is being used, observe Lower (spring-loaded) Crimping Die as Handles are closed part way. When Wire Barrel Crimping Die has entered Crimping Port, close Handles until CERTI-CRIMP* Ratchet releases to complete crimp.
- (h) If Pneumatic Tool No. 69365 is to be used, Manual Take-Up Attachment No. 69689 should be installed on Tool. This device will allow lower Crimping Die to be manually closed on the Contact while observing entrance of wire barrel Crimping Die in Crimping Port. Refer to Instruction Sheet shipped with Manual Take-Up Attachment No. 69689 for installation instructions for this accessory. Proceed as follows after Take-Up Attachment has been installed. This procedure also applies to Tool No. 69365-2.
 1. Place Contact on Stationary Die as previously described. See Figures 3 and 4.
 2. Pull handle on Take-Up Attachment forward to close Die on Contact.
 3. After Die has entered Crimping Port, Crimping Button can be pressed to complete crimp.

MANUAL TAKE-UP ATTACHMENT NO. 69689 USED
ON TOOL NO. 69365 (FACTORY INSTALLED ON
TOOL NO. 69365-2)

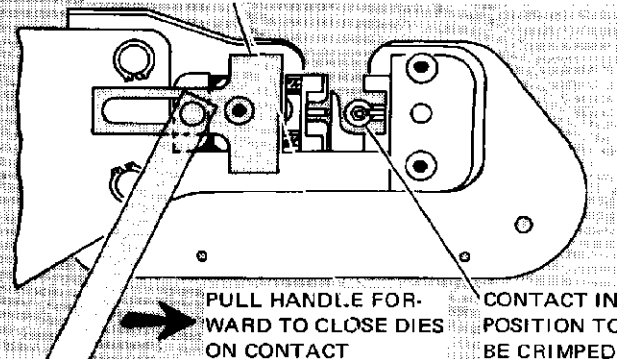

Figure 4