

C-MOS 3-TERMINAL POSITIVE VOLTAGE REGULATOR

■ GENERAL DESCRIPTION

The **NJU7201 series** is a C-MOS 3-terminal positive voltage regulator which contains internal accurate voltage reference, error amplifier, control transistor and output voltage setting resistor.

The regulation voltage is fixed by internal circuits and the following line-up of different output voltage versions are available.

The **NJU7201 series** is suitable for battery operated items and battery back-up systems because of low operating current and low dropout voltage.

■ PACKAGE OUTLINE

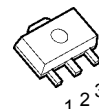

NJU7201U (SOT-89)

■ FEATURES

- Low Operating Current (19 μ A typ.)
- Wide Operating Voltage Range
- Low Dropout Voltage
 - ($\Delta V_{IO} < 0.3V$ 1.2 to 1.5V output, $I_{OUT} = 0.5mA$)
 - ($\Delta V_{IO} < 0.6V$ 2.5 to 3.5V output, $I_{OUT} = 20mA$)
 - ($\Delta V_{IO} < 0.6V$ 4.0 to 5.5V output, $I_{OUT} = 40mA$)
- Small Temperature Coefficient of Output Voltage
- Package Outline (SOT-89)
- C-MOS Technology

■ TERMINAL DESCRIPTION

No.	Description
1	GND
2	Input
3	Output

■ OUTPUT VOLTAGE LINE-UP

Output Voltage	SOT-89 Type	Output Voltage	SOT-89 Type
+1.2V	NJU7201U12	+3.5V	NJU7201U35
+1.5V	NJU7201U15	+4.0V	NJU7201U40
+2.5V	NJU7201U25	+4.5V	NJU7201U45
+2.7V	NJU7201U27	+5.0V	NJU7201U50
+3.0V	NJU7201U30	+5.2V	NJU7201U52
+3.2V	NJU7201U32	+5.5V	NJU7201U55

■ EQUIVALENT CIRCUIT

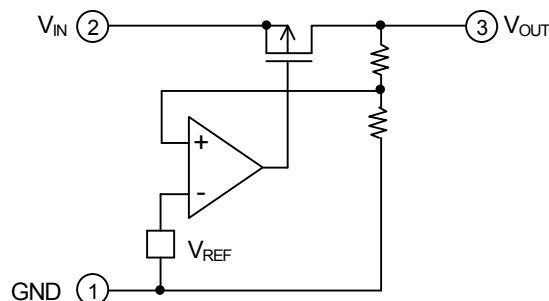

NJU7201 Series

■ ABSOLUTE MAXIMUM RATINGS

($T_a = 25^\circ\text{C}$)

PARAMETER	SYMBOL	RATINGS	UNIT
Input Voltage	V_{IN}	14	V
Output Voltage	V_{OUT}	$V_{IN}+0.3$ to GND-0.3	V
Output Current	I_{OUT}	100	mA
Power Dissipation	P_D	300 (SOT-89)	mW
Operating Temperature	T_{opr}	-25 to +75	$^\circ\text{C}$
Storage Temperature	T_{stg}	-40 to +125	$^\circ\text{C}$

■ ELECTRICAL CHARACTERISTICS

+1.2V Version

($C_{IN} = C_o = 0.1\mu\text{F}$, $T_a = 25^\circ\text{C}$)

PARAMETER	SYMBOL	CONDITION	MIN.	TYP.	MAX.	UNIT
Output Voltage	V_{OUT}	$V_{IN} = 3.0\text{V}$, $I_{OUT} = 5\text{mA}$	1.14	1.20	1.26	V
Dropout Voltage	ΔV_{IO}	$I_{OUT} = 0.5\text{mA}$	-	0.020	0.30	V
Input Voltage	V_{IN}		-	-	12	V
Operating Current	I_Q	$V_{IN} = 3.0\text{V}$	-	19	30	μA
Load Regulation	$\Delta V_{OUT} / \Delta I_{OUT}$	$V_{IN} = 3.0\text{V}$, $I_{OUT} = 1 \sim 15\text{mA}$	-	10	180	mV
Line Regulation	$\Delta V_{OUT} / (\Delta V_{IN} \cdot V_{OUT})$	$V_{IN} = 1.5 \sim 12\text{V}$	-	0.10	-	%/V

+1.5V Version

($C_{IN} = C_o = 0.1\mu\text{F}$, $T_a = 25^\circ\text{C}$)

PARAMETER	SYMBOL	CONDITION	MIN.	TYP.	MAX.	UNIT
Output Voltage	V_{OUT}	$V_{IN} = 3.0\text{V}$, $I_{OUT} = 5\text{mA}$	1.425	1.500	1.575	V
Dropout Voltage	ΔV_{IO}	$I_{OUT} = 0.5\text{mA}$	-	0.020	0.30	V
Input Voltage	V_{IN}		-	-	12	V
Operating Current	I_Q	$V_{IN} = 3.0\text{V}$	-	19	30	μA
Load Regulation	$\Delta V_{OUT} / \Delta I_{OUT}$	$V_{IN} = 3.0\text{V}$, $I_{OUT} = 1 \sim 15\text{mA}$	-	-	180	mV
Line Regulation	$\Delta V_{OUT} / (\Delta V_{IN} \cdot V_{OUT})$	$V_{IN} = 1.8 \sim 12\text{V}$	-	0.10	-	%/V

+2.5V Version

($C_{IN} = C_o = 0.1\mu\text{F}$, $T_a = 25^\circ\text{C}$)

PARAMETER	SYMBOL	CONDITION	MIN.	TYP.	MAX.	UNIT
Output Voltage	V_{OUT}	$V_{IN} = 4.5\text{V}$, $I_{OUT} = 10\text{mA}$	2.375	2.500	2.625	V
Dropout Voltage	ΔV_{IO}	$I_{OUT} = 20\text{mA}$	-	0.20	0.60	V
Input Voltage	V_{IN}		-	-	12	V
Operating Current	I_Q	$V_{IN} = 4.5\text{V}$	-	19	30	μA
Load Regulation	$\Delta V_{OUT} / \Delta I_{OUT}$	$V_{IN} = 4.5\text{V}$, $I_{OUT} = 1 \sim 20\text{mA}$	-	-	180	mV
Line Regulation	$\Delta V_{OUT} / (\Delta V_{IN} \cdot V_{OUT})$	$V_{IN} = 3.5 \sim 12\text{V}$	-	0.10	-	%/V

+2.7V Version

($C_{IN} = C_o = 0.1\mu\text{F}$, $T_a = 25^\circ\text{C}$)

PARAMETER	SYMBOL	CONDITION	MIN.	TYP.	MAX.	UNIT
Output Voltage	V_{OUT}	$V_{IN} = 4.7\text{V}$, $I_{OUT} = 10\text{mA}$	2.565	2.700	2.835	V
Dropout Voltage	ΔV_{IO}	$I_{OUT} = 20\text{mA}$	-	0.20	0.60	V
Input Voltage	V_{IN}		-	-	12	V
Operating Current	I_Q	$V_{IN} = 4.7\text{V}$	-	19	30	μA
Load Regulation	$\Delta V_{OUT} / \Delta I_{OUT}$	$V_{IN} = 4.7\text{V}$, $I_{OUT} = 1 \sim 20\text{mA}$	-	-	180	mV
Line Regulation	$\Delta V_{OUT} / (\Delta V_{IN} \cdot V_{OUT})$	$V_{IN} = 3.7 \sim 12\text{V}$	-	0.10	-	%/V

NJU7201 Series

+3.0V Version

($C_{IN} = C_o = 0.1\mu F$, $T_a = 25^\circ C$)

PARAMETER	SYMBOL	CONDITION	MIN.	TYP.	MAX.	UNIT
Output Voltage	V_{OUT}	$V_{IN} = 5.0V$, $I_{OUT} = 10mA$	2.85	3.00	3.15	V
Dropout Voltage	ΔV_{IO}	$I_{OUT} = 20mA$	-	0.20	0.60	V
Input Voltage	V_{IN}		-	-	12	V
Operating Current	I_Q	$V_{IN} = 5.0V$	-	19	30	μA
Load Regulation	$\Delta V_{OUT} / \Delta I_{OUT}$	$V_{IN} = 5.0V$, $I_{OUT} = 1 \sim 20mA$	-	15	180	mV
Line Regulation	$\Delta V_{OUT} / (\Delta V_{IN} \cdot V_{OUT})$	$V_{IN} = 4.0 \sim 12.0V$	-	0.10	-	%/V

+3.2V Version

($C_{IN} = C_o = 0.1\mu F$, $T_a = 25^\circ C$)

PARAMETER	SYMBOL	CONDITION	MIN.	TYP.	MAX.	UNIT
Output Voltage	V_{OUT}	$V_{IN} = 5.2V$, $I_{OUT} = 10mA$	3.04	3.20	3.36	V
Dropout Voltage	ΔV_{IO}	$I_{OUT} = 20mA$	-	0.20	0.60	V
Input Voltage	V_{IN}		-	-	12	V
Operating Current	I_Q	$V_{IN} = 5.2V$	-	19	30	μA
Load Regulation	$\Delta V_{OUT} / \Delta I_{OUT}$	$V_{IN} = 5.2V$, $I_{OUT} = 1 \sim 20mA$	-	-	180	mV
Line Regulation	$\Delta V_{OUT} / (\Delta V_{IN} \cdot V_{OUT})$	$V_{IN} = 4.2 \sim 12.0V$	-	0.10	-	%/V

+3.5V Version

($C_{IN} = C_o = 0.1\mu F$, $T_a = 25^\circ C$)

PARAMETER	SYMBOL	CONDITION	MIN.	TYP.	MAX.	UNIT
Output Voltage	V_{OUT}	$V_{IN} = 5.5V$, $I_{OUT} = 10mA$	3.325	3.500	3.675	V
Dropout Voltage	ΔV_{IO}	$I_{OUT} = 20mA$	-	0.20	0.60	V
Input Voltage	V_{IN}		-	-	12	V
Operating Current	I_Q	$V_{IN} = 5.5V$	-	19	30	μA
Load Regulation	$\Delta V_{OUT} / \Delta I_{OUT}$	$V_{IN} = 5.5V$, $I_{OUT} = 1 \sim 20mA$	-	-	180	mV
Line Regulation	$\Delta V_{OUT} / (\Delta V_{IN} \cdot V_{OUT})$	$V_{IN} = 4.5 \sim 12.0V$	-	0.10	-	%/V

+4.0V Version

($C_{IN} = C_o = 0.1\mu F$, $T_a = 25^\circ C$)

PARAMETER	SYMBOL	CONDITION	MIN.	TYP.	MAX.	UNIT
Output Voltage	V_{OUT}	$V_{IN} = 6.0V$, $I_{OUT} = 30mA$	3.8	4.0	4.2	V
Dropout Voltage	ΔV_{IO}	$I_{OUT} = 40mA$	-	0.30	0.60	V
Input Voltage	V_{IN}		-	-	12	V
Operating Current	I_Q	$V_{IN} = 6.0V$	-	19	30	μA
Load Regulation	$\Delta V_{OUT} / \Delta I_{OUT}$	$V_{IN} = 6.0V$, $I_{OUT} = 1 \sim 40mA$	-	-	120	mV
Line Regulation	$\Delta V_{OUT} / (\Delta V_{IN} \cdot V_{OUT})$	$V_{IN} = 5.0 \sim 12.0V$	-	0.10	-	%/V

NJU7201 Series

+4.5V Version

($C_{IN} = C_o = 0.1\mu F, T_a = 25^\circ C$)

PARAMETER	SYMBOL	CONDITION	MIN.	TYP.	MAX.	UNIT
Output Voltage	V_{OUT}	$V_{IN} = 6.5V, I_{OUT} = 30mA$	4.275	4.5	4.725	V
Dropout Voltage	ΔV_{IO}	$I_{OUT} = 40mA$	-	0.30	0.60	V
Input Voltage	V_{IN}		-	-	12	V
Operating Current	I_Q	$V_{IN} = 6.5V$	-	19	30	μA
Load Regulation	$\Delta V_{OUT} / \Delta I_{OUT}$	$V_{IN} = 6.5V, I_{OUT} = 1 \sim 40mA$	-	-	120	mV
Line Regulation	$\Delta V_{OUT} / (\Delta V_{IN} \cdot V_{OUT})$	$V_{IN} = 5.5 \sim 12.0V$	-	0.10	-	%/V

+5.0V Version

($C_{IN} = C_o = 0.1\mu F, T_a = 25^\circ C$)

PARAMETER	SYMBOL	CONDITION	MIN.	TYP.	MAX.	UNIT
Output Voltage	V_{OUT}	$V_{IN} = 7.0V, I_{OUT} = 30mA$	4.75	5.00	5.25	V
Dropout Voltage	ΔV_{IO}	$I_{OUT} = 40mA$	-	0.30	0.60	V
Input Voltage	V_{IN}		-	-	12	V
Operating Current	I_Q	$V_{IN} = 7.0V$	-	19	30	μA
Load Regulation	$\Delta V_{OUT} / \Delta I_{OUT}$	$V_{IN} = 7.0V, I_{OUT} = 1 \sim 40mA$	-	35	120	mV
Line Regulation	$\Delta V_{OUT} / (\Delta V_{IN} \cdot V_{OUT})$	$V_{IN} = 6.0 \sim 12.0V$	-	0.10	-	%/V

+5.2V Version

($C_{IN} = C_o = 0.1\mu F, T_a = 25^\circ C$)

PARAMETER	SYMBOL	CONDITION	MIN.	TYP.	MAX.	UNIT
Output Voltage	V_{OUT}	$V_{IN} = 7.2V, I_{OUT} = 30mA$	4.94	5.20	5.46	V
Dropout Voltage	ΔV_{IO}	$I_{OUT} = 40mA$	-	0.30	0.60	V
Input Voltage	V_{IN}		-	-	12	V
Operating Current	I_Q	$V_{IN} = 7.2V$	-	19	30	μA
Load Regulation	$\Delta V_{OUT} / \Delta I_{OUT}$	$V_{IN} = 7.2V, I_{OUT} = 1 \sim 40mA$	-	-	120	mV
Line Regulation	$\Delta V_{OUT} / (\Delta V_{IN} \cdot V_{OUT})$	$V_{IN} = 6.2 \sim 12.0V$	-	0.10	-	%/V

+5.5V Version

($C_{IN} = C_o = 0.1\mu F, T_a = 25^\circ C$)

PARAMETER	SYMBOL	CONDITION	MIN.	TYP.	MAX.	UNIT
Output Voltage	V_{OUT}	$V_{IN} = 7.5V, I_{OUT} = 30mA$	5.225	5.500	5.775	V
Dropout Voltage	ΔV_{IO}	$I_{OUT} = 40mA$	-	0.30	0.60	V
Input Voltage	V_{IN}		-	-	12	V
Operating Current	I_Q	$V_{IN} = 7.5V$	-	19	30	μA
Load Regulation	$\Delta V_{OUT} / \Delta I_{OUT}$	$V_{IN} = 7.5V, I_{OUT} = 1 \sim 40mA$	-	-	120	mV
Line Regulation	$\Delta V_{OUT} / (\Delta V_{IN} \cdot V_{OUT})$	$V_{IN} = 6.5 \sim 12.0V$	-	0.10	-	%/V

MEASUREMENT CIRCUIT

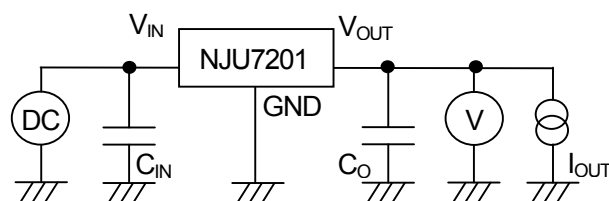

■ TYPICAL CHARACTERISTICS

Output Voltage vs. Input Voltage

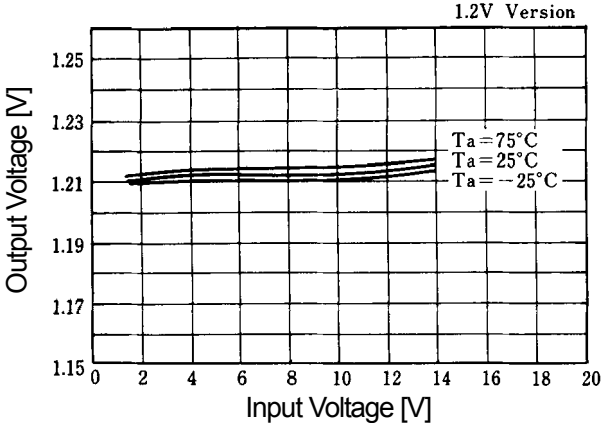

Output Voltage vs. Input Temperature

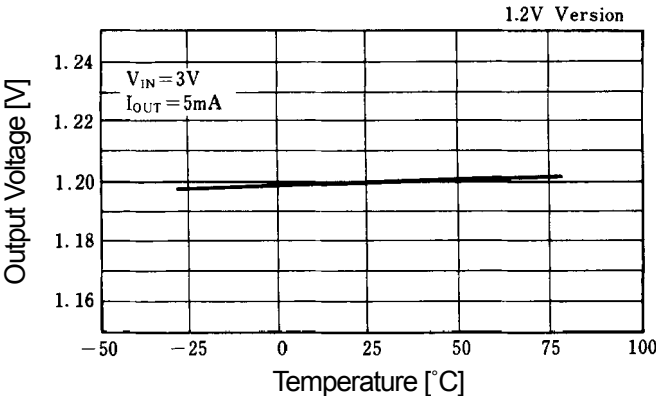

Output Voltage vs. Input Voltage

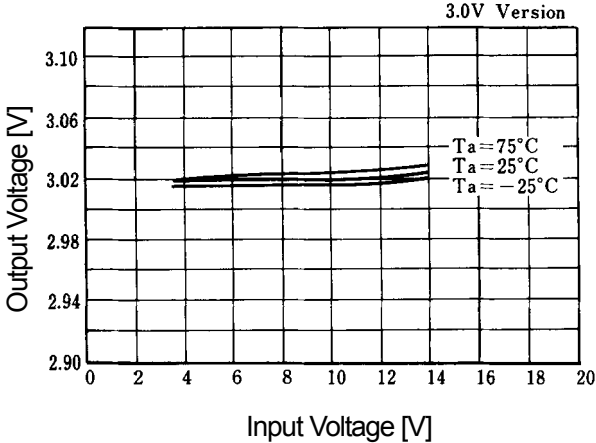

Output Voltage vs. Input Temperature

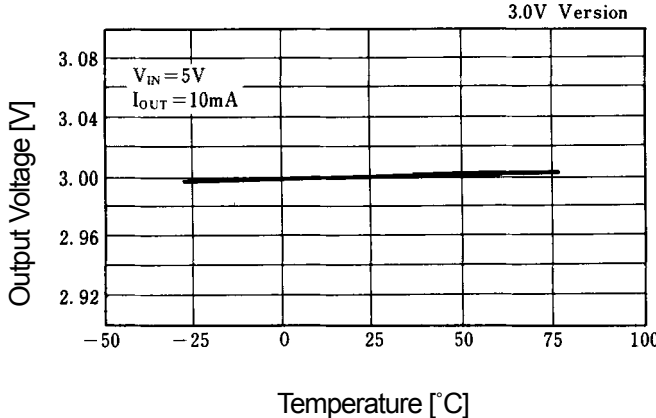

Output Voltage vs. Input Voltage

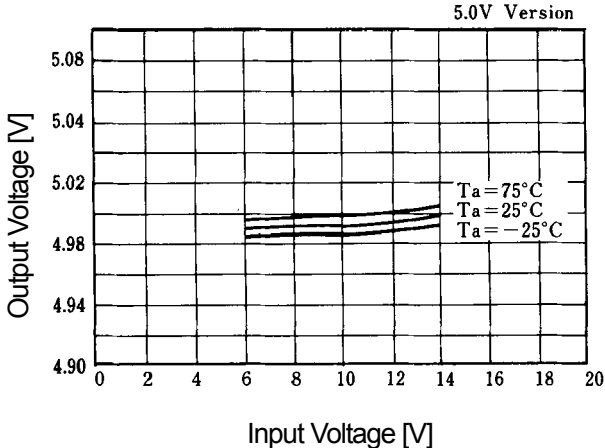

Output Voltage vs. Input Temperature

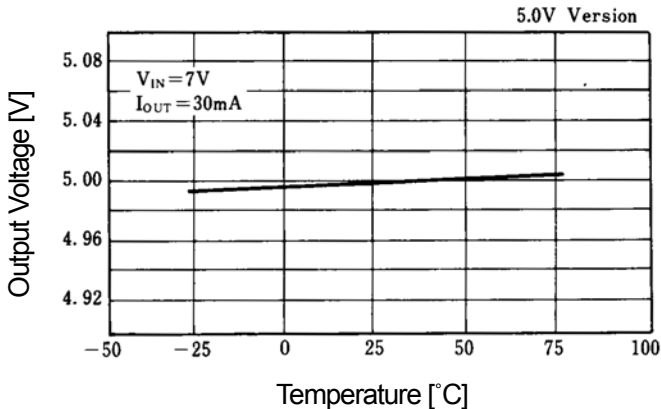

NJU7201 Series

■ TYPICAL CHARACTERISTICS

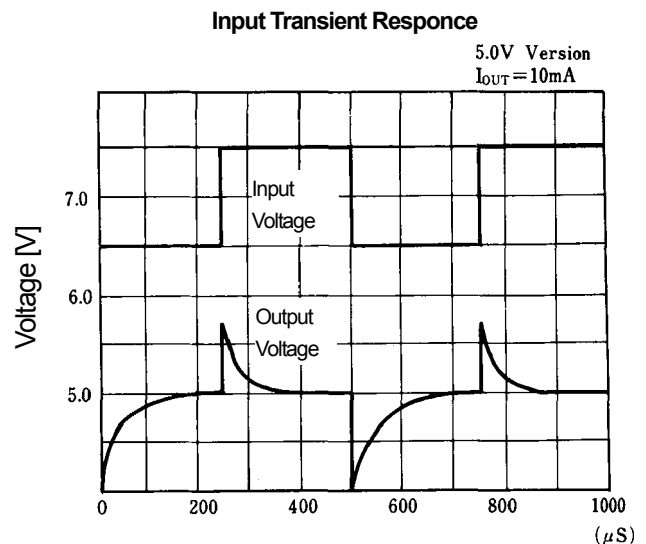
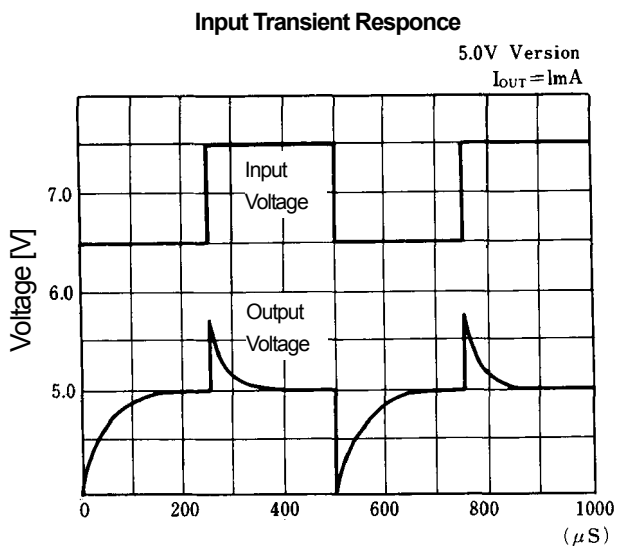
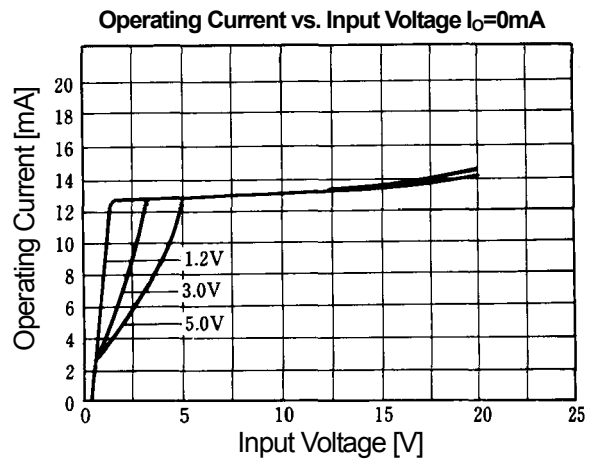
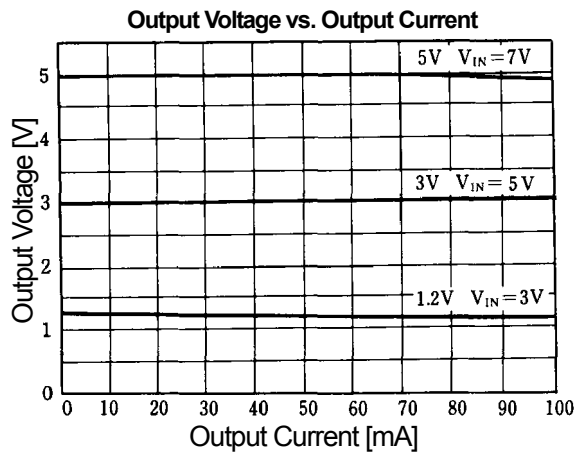
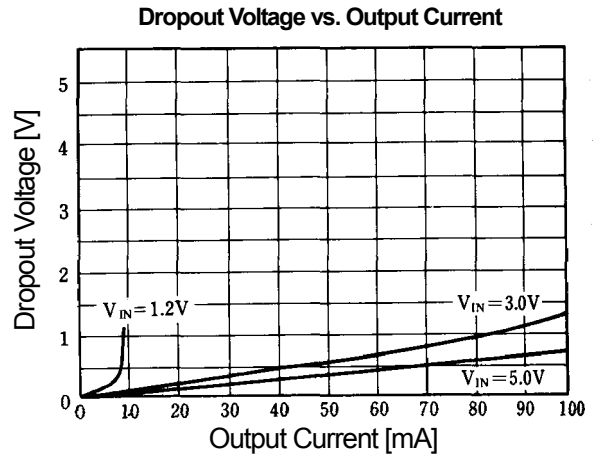
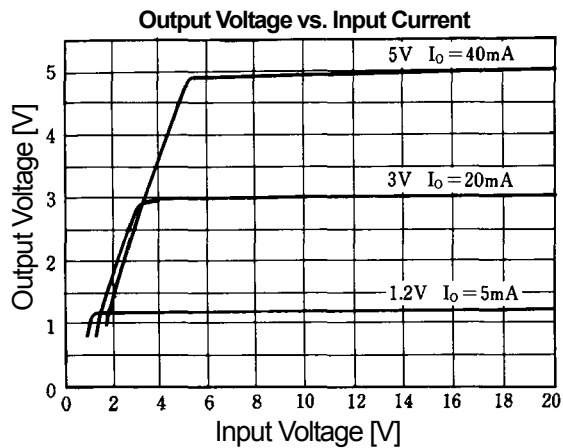

[CAUTION]
The specifications on this databook are only given for information, without any guarantee as regards either mistakes or omissions. The application circuits in this databook are described only to show representative usages of the product and not intended for the guarantee or permission of any right including the industrial rights.