

87C196KC

16-Bit High-Performance CHMOS Microcontroller

The 87C196KC 16-bit microcontroller is a high-performance member of the MCS® 96 microcontroller family. The 87C196KC is an enhanced 8XC196KB device with 488 bytes RAM, 16 MHz operation and 16 Kbytes of on-chip EPROM. This CHMOS process provides a high performance processor along with low power consumption.

Four high-speed capture inputs are provided to record times when events occur. Six high-speed outputs are available for pulse or waveform generation. The high-speed output can also generate four software timers or start an A/D conversion. Events can be based on the timer or up/down counter.

Rochester Electronics Manufactured Components

Rochester branded components are manufactured using either die/wafers purchased from the original suppliers or Rochester wafers recreated from the original IP. All re-creations are done with the approval of the Original Component Manufacturer (OCM).

Parts are tested using original factory test programs or Rochester developed test solutions to guarantee product meets or exceeds the OCM data sheet.

Quality Overview

- ISO-9001
- AS9120 certification
- Qualified Manufacturers List (QML) MIL-PRF-35835
 - Class Q Military
 - Class V Space Level
- Qualified Suppliers List of Distributors (QSLD)
 - Rochester is a critical supplier to DLA and meets all industry and DLA standards.

Rochester Electronics, LLC is committed to supplying products that satisfy customer expectations for quality and are equal to those originally supplied by industry manufacturers.

The original manufacturer's datasheet accompanying this document reflects the performance and specifications of the Rochester manufactured version of this device. Rochester Electronics guarantees the performance of its semiconductor products to the original OCM specifications. 'Typical' values are for reference purposes only. Certain minimum or maximum ratings may be based on product characterization, design, simulation, or sample testing.

FOR REFERENCE ONLY



87C196KC

16-BIT HIGH-PERFORMANCE CHMOS MICROCONTROLLER

Automotive

- -40°C to $+125^{\circ}\text{C}$
- 16 Kbytes of On-Chip EPROM
- 232 Byte Register File
- 256 Bytes of Additional RAM
- Register-to-Register Architecture
- 28 Interrupt Sources/16 Vectors
- Peripheral Transaction Server
- $1.75\ \mu\text{s}$ 16 x 16 Multiply (16 MHz)
- $3.0\ \mu\text{s}$ 32/16 Divide (16 MHz)
- Powerdown and Idle Modes
- Five 8-Bit I/O Ports
- 16-Bit Watchdog Timer
- Dynamically Configurable 8-Bit or 16-Bit Buswidth
- Full Duplex Serial Port
- High-Speed I/O Subsystem
- 16-Bit Timer
- 16-Bit Up/Down Counter with Capture
- 3 Pulse-Width-Modulated Outputs
- Four 16-Bit Software Timers
- 8- or 10-Bit 8-Channel A/D Converter with Sample/Hold
- $\overline{\text{HOLD}}/\overline{\text{HLDA}}$ Bus Protocol
- OTP One-Time Programmable and QROM Versions
- Available in 12 MHz and 16 MHz Versions
- 16 MHz Operation

The 87C196KC 16-bit microcontroller is a high-performance member of the MCS[®] 96 microcontroller family. The 87C196KC is an enhanced 8XC196KB device with 488 bytes RAM, 16 MHz operation and 16 Kbytes of on-chip EPROM. Intel's CHMOS process provides a high performance processor along with low power consumption.

Four high-speed capture inputs are provided to record times when events occur. Six high-speed outputs are available for pulse or waveform generation. The high-speed output can also generate four software timers or start an A/D conversion. Events can be based on the timer or up/down counter.

NOTICE:

This datasheet contains information on products in full production. Specifications within this datasheet are subject to change without notice. Verify with your local Intel sales office that you have the latest datasheet before finalizing a design.

*Other brands and names are the property of their respective owners.

Information in this document is provided in connection with Intel products. Intel assumes no liability whatsoever, including infringement of any patent or copyright, for sale and use of Intel products except as provided in Intel's Terms and Conditions of Sale for such products. Intel retains the right to make changes to these specifications at any time, without notice. Microcomputer Products may have minor variations to this specification known as errata.

COPYRIGHT © INTEL CORPORATION, 2004

July 2004

Order Number 270864-005

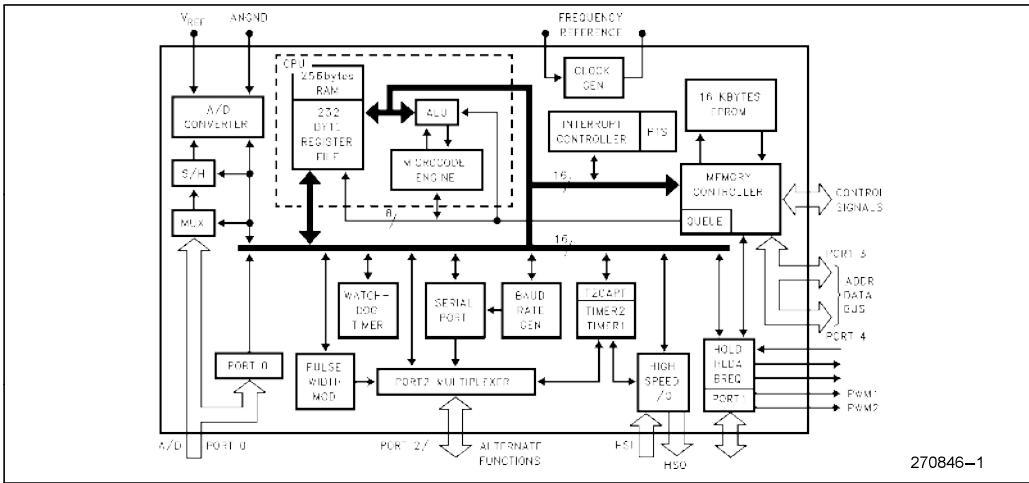

Figure 1. 87C196KC Block Diagram

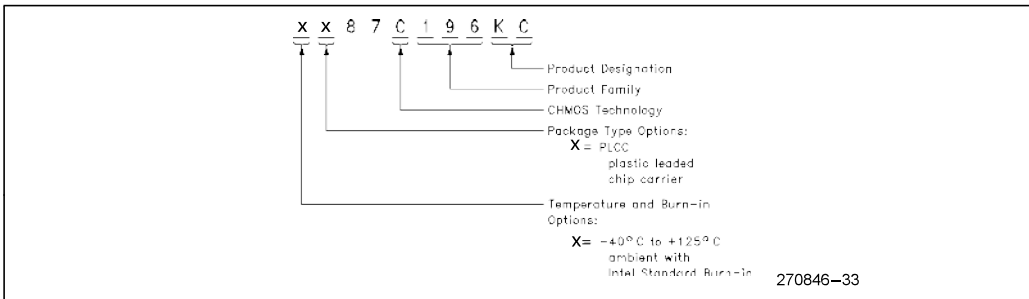

Figure 2. The 87C196KC Family Nomenclature

87C196KC Enhanced Feature Set over the 87C196KB

1. The 87C196KC has twice the RAM and twice the EPROM of the 87C196KB. Also, a Vertical Register Windowing Scheme allows the extra 256 bytes of RAM to be used as registers. This greatly reduces the context switching time.
2. Peripheral Transaction Server (PTS). The PTS is an alternative way to service an interrupt, reducing latency and overhead. Each interrupt can be mapped to its PTS channel, which acts like a DMA channel. Each interrupt can now do a single or block transfer, without executing an Interrupt service routine. Special PTS modes exist for the A/D converter, HSI, and HSO.
3. Two extra Pulse Width Modulated outputs. The 87C196KC has added 2 PWM outputs that are functionally compatible to the 87C196KB PWM.
4. Timer2 Internal Clocking. Timer2 can now be clocked with an internal source, every 1 or 8 state times.
5. The A/D can now perform an 8- as well as a 10-bit conversion. 8-bit conversion allows for a faster conversion time.
6. Additional On-chip Memory Security. Two UPROM (Uneraseable Programmable Read Only Memory) bits can be programmed to disable the bus controller for external code and data fetches. Once programmed, a UPROM bit cannot be erased. By shutting off the bus controller for external fetches, no one can try and gain access to your code by executing from external memory.
7. New Instructions. The 87C196KC has 5 new instructions. An exchange (XCHB/XCHW) instruction swaps two memory locations, an Interruptable Block Move Instruction (BMOVI), a Table Indirect Jump (TIJMP) instruction, and two instructions for enabling and disabling the PTS (EPTS/DPTS).

PACKAGING

PLCC	Description	PLCC	Description	PLCC	Description
9	ACH7/P0.7	54	AD6/P3.6	31	P1.6/ $\overline{\text{HLDA}}$
8	ACH6/P0.6	53	AD7/P3.7	30	P1.5/ $\overline{\text{BREQ}}$
7	ACH2/P0.2	52	AD8/P4.0	29	HSO.1
6	ACH0/P0.0	51	AD9/P4.1	28	HSO.0
5	ACH1/P0.1	50	AD10/P4.2	27	HSO.5/HSI.3
4	ACH3/P0.3	49	AD11/P4.3	26	HSO.4/HSI.2
3	NMI	48	AD12/P4.4	25	HSI.1
2	$\overline{\text{EA}}$	47	AD13/P4.5	24	HSI.0
1	V _{CC}	46	AD14/P4.6	23	P1.4/PWM2
68	V _{SS}	45	AD15/P4.7	22	P1.3/PWM1
67	XTAL1	44	T2CLK/P2.3	21	P1.2
66	XTAL2	43	READY	20	P1.1
65	CLKOUT	42	T2RST/P2.4	19	P1.0
64	BUSWIDTH	41	$\overline{\text{BHE}}/\overline{\text{WRH}}$	18	TXD/P2.0
63	INST	40	$\overline{\text{WR}}/\overline{\text{WRL}}$	17	RXD/P2.1
62	$\overline{\text{ALE}}/\overline{\text{ADV}}$	39	PWM0/P2.5	16	$\overline{\text{RESET}}$
61	$\overline{\text{RD}}$	38	P2.7/T2CAPTURE	15	EXTINT/P2.2
60	AD0/P3.0	37	V _{PP}	14	V _{SS}
59	AD1/P3.1	36	V _{SS}	13	V _{REF}
58	AD2/P3.2	35	HSO.3	12	ANGND
57	AD3/P3.3	34	HSO.2	11	ACH4/P.04
56	AD4/P3.4	33	P2.6/T2UP-DN	10	ACH5/P.05
55	AD5/P3.5	32	P1.7/ $\overline{\text{HOLD}}$		

Figure 3. 68-Pin PLCC Functional Pin-out

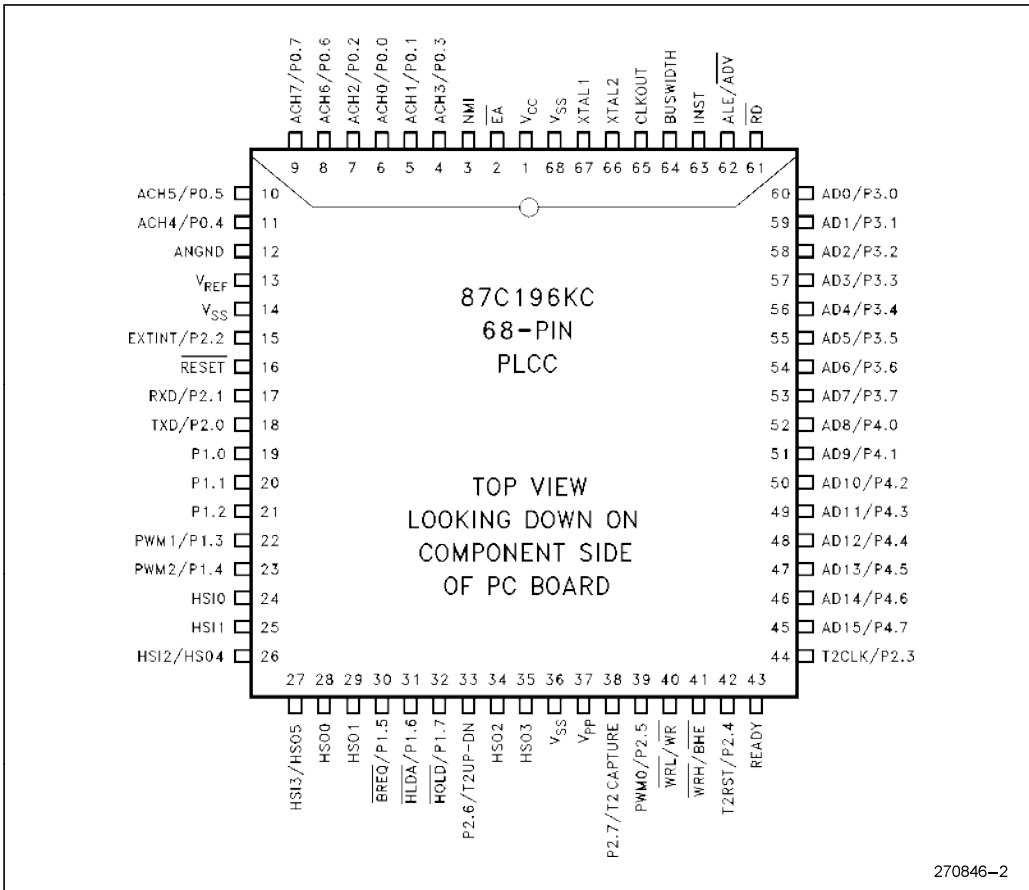

Figure 4. 68-Pin PLCC Package

PIN DESCRIPTIONS

Symbol	Name and Function
V _{CC}	Main supply voltage (5V).
V _{SS}	Digital circuit ground (0V). There are three V _{SS} pins, all of which must be connected.
V _{REF}	Reference voltage for the A/D converter (5V). V _{REF} is also the supply voltage to the analog portion of the A/D converter and the logic used to read Port 0. Must be connected for A/D and Port 0 to function.
ANGND	Reference ground for the A/D converter. Must be held at nominally the same potential as V _{SS} .
V _{PP}	Timing pin for the return from powerdown circuit. Connect this pin with a 1 μF capacitor to V _{SS} and a 1 MΩ resistor to V _{CC} . If this function is not used V _{PP} may be tied to V _{CC} . This pin is the programming voltage on the EPROM device.
XTAL1	Input of the oscillator inverter and of the internal clock generator.
XTAL2	Output of the oscillator inverter.
CLKOUT	Output of the internal clock generator. The frequency of CLKOUT is 1/2 the oscillator frequency.
$\overline{\text{RESET}}$	Reset input to the chip.
BUSWIDTH	Input for buswidth selection. If CCR bit 1 is a one, this pin selects the bus width for the bus cycle in progress. If BUSWIDTH is a 1, a 16-bit bus cycle occurs. If BUSWIDTH is a 0 an 8-bit cycle occurs. If CCR bit 1 is a 0, the bus is always an 8-bit bus.
NMI	A positive transition causes a vector through 203EH.
INST	Output high during an external memory read indicates the read is an instruction fetch. INST is valid throughout the bus cycle. INST is activated only during external memory accesses and output low for a data fetch.
$\overline{\text{EA}}$	Input for memory select (External Access). $\overline{\text{EA}}$ equal to a TTL-high causes memory accesses to locations 2000H through 5FFFH to be directed to on-chip ROM/EPROM. $\overline{\text{EA}}$ equal to a TTL-low causes accesses to those locations to be directed to off-chip memory.
ALE/ $\overline{\text{ADV}}$	Address Latch Enable or Address Valid output, as selected by CCR. Both pin options provide a signal to demultiplex the address from the address/data bus. When the pin is $\overline{\text{ADV}}$, it goes inactive high at the end of the bus cycle. ALE/ $\overline{\text{ADV}}$ is activated only during external memory accesses.
$\overline{\text{RD}}$	Read signal output to external memory. $\overline{\text{RD}}$ is activated only during external memory reads.
$\overline{\text{WR}}$ /WRL	Write and Write Low output to external memory, as selected by the CCR. $\overline{\text{WR}}$ will go low for every external write, while WRL will go low only for external writes where an even byte is being written. $\overline{\text{WR}}$ /WRL is activated only during external memory writes.
$\overline{\text{BHE}}$ /WRH	Bus High Enable or Write High output to external memory, as selected by the CCR. $\overline{\text{BHE}} = 0$ selects the bank of memory that is connected to the high byte of the data bus. $\text{A0} = 0$ selects the bank of memory that is connected to the low byte of the data bus. Thus accesses to a 16-bit wide memory can be to the low byte only ($\text{A0} = 0$, $\overline{\text{BHE}} = 1$), to the high byte only ($\text{A0} = 1$, $\overline{\text{BHE}} = 0$), or both bytes ($\text{A0} = 0$, $\overline{\text{BHE}} = 0$). If the WRH function is selected, the pin will go low if the bus cycle is writing to an odd memory location. $\overline{\text{BHE}}$ /WRH is valid only during 16-bit external memory write cycles.





PIN DESCRIPTIONS (Continued)

Symbol	Name and Function
READY	Ready input to lengthen external memory cycles, for interfacing to slow or dynamic memory, or for bus sharing. When the external memory is not being used, READY has no effect.
HSI	Inputs to High Speed Input Unit. Four HSI pins are available: HSI.0, HSI.1, HSI.2 and HSI.3. Two of them (HSI.2 and HSI.3) are shared with the HSO Unit.
HSO	Outputs from High Speed Output Unit. Six HSO pins are available: HSO.0, HSO.1, HSO.2, HSI.3, HSO.4 and HSO.5. Two of them (HSO.4 and HSO.5) are shared with the HSI Unit.
Port 0	8-bit high impedance input-only port. These pins can be used as digital inputs and/or as analog inputs to the on-chip A/D converter.
Port 1	8-bit quasi-bidirectional I/O port.
Port 2	8-bit multi-functional port. All of its pins are shared with other functions in the 87C196KC.
Ports 3 and 4	8-bit bidirectional I/O ports with open drain outputs. These pins are shared with the multiplexed address/data bus.
$\overline{\text{HOLD}}$	Bus Hold input requesting control of the bus.
$\overline{\text{HLDA}}$	Bus Hold acknowledge output indicating release of the bus.
$\overline{\text{BREQ}}$	Bus Request output activated when the bus controller has a pending external memory cycle.





ELECTRICAL CHARACTERISTICS

NOTICE: This is a production data sheet. The specifications are subject to change without notice.

Absolute Maximum Ratings*

Ambient Temperature
 Under Bias -40°C to +125°C
 Storage Temperature -65°C to +150°C
 Voltage On Any Pin to V_{SS} -0.5V to +7.0V
 Power Dissipation 0.43W

**WARNING: Stressing the device beyond the “Absolute Maximum Ratings” may cause permanent damage. These are stress ratings only. Operation beyond the “Operating Conditions” is not recommended and extended exposure beyond the “Operating Conditions” may affect device reliability.*

OPERATING CONDITIONS

Symbol	Description	Min	Max	Units
T _A	Ambient Temperature Under Bias	-40	+125	°C
V _{CC}	Digital Supply Voltage	4.50	5.50	V
V _{REF}	Analog Supply Voltage	4.50	5.50	V
F _{OSC}	Oscillator Frequency	4	16	MHz

NOTE:
 ANGND and V_{SS} should be nominally at the same potential.

DC CHARACTERISTICS (Over Specified Operating Conditions)

Symbol	Description	Min	Max	Units	Test Conditions
V _{IL}	Input Low Voltage	-0.5	0.8	V	
V _{IH}	Input High Voltage (Note 1)	0.2 V _{CC} + 1.0	V _{CC} + 0.5	V	
V _{IH1}	Input High Voltage on XTAL 1, EA	0.7 V _{CC}	V _{CC} + 0.5	V	
V _{IH2}	Input High Voltage on RESET	2.2	V _{CC} + 0.5	V	
V _{OL}	Output Low Voltage		0.3 0.45 1.5	V	I _{OL} = 200 μA I _{OL} = 2.8 mA I _{OL} = 7 mA
V _{OL1}	Output Low Voltage in RESET on P2.5 (Note 2)		0.8	V	I _{OL} = +0.2 mA
V _{OH}	Output High Voltage (Standard Outputs)	V _{CC} - 0.3 V _{CC} - 0.7 V _{CC} - 1.5		V	I _{OH} = -200 μA I _{OH} = -3.2 mA I _{OH} = -7 mA
V _{OH1}	Output High Voltage (Quasi-bidirectional Outputs)	V _{CC} - 0.3 V _{CC} - 0.7 V _{CC} - 1.5		V	I _{OH} = -10 μA I _{OH} = -30 μA I _{OH} = -60 μA
V _{OH2}	Output High Voltage in RESET on P2.0 (Note 2)	2.0		V	I _{OH} = -0.6 mA

NOTES:
 1. All pins except RESET, XTAL1 and EA.
 2. Violating these specifications in Reset may cause the part to enter test modes.





DC CHARACTERISTICS (Over Specified Operating Conditions)

Symbol	Description	Min	Typ	Max	Units	Test Conditions
I_{LI}	Input Leakage Current (Std. Inputs)			± 10	μA	$0 < V_{IN} < V_{CC} - 0.3V$
I_{LI1}	Input Leakage Current (Port 0)			± 3	μA	$0 < V_{IN} < V_{REF}$
I_{TL}	1 to 0 Transition Current (QBD Pins)			-650	μA	$V_{IN} = 2.0V$
I_{IL}	Logical 0 Input Current (QBD Pins)			-70	μA	$V_{IN} = 0.45V$
I_{CC}	Active Mode Current in Reset		50	70	mA	XTAL1 = 16 MHz $V_{CC} = V_{PP} = V_{REF} = 5.5V$
I_{REF}	A/D Converter Reference Current		2	5	mA	
I_{IDLE}	Idle Mode Current		15	30	mA	$V_{CC} = V_{PP} = V_{REF} = 5.5V$
I_{PD}	Powerdown Mode Current		50	T.B.D.	μA	
R_{RST}	Reset Pullup Resistor	6K		65K	Ω	$V_{CC} = 5.0V, V_{IN} = 4.0V$
C_S	Pin Capacitance (Any Pin to V_{SS})			10	pF	

NOTES:

(Notes apply to all specifications)

1. QBD (Quasi-bidirectional) pins include Port 1, P2.6 and P2.7.
2. Standard Outputs include AD0-15, \overline{RD} , \overline{WR} , ALE, \overline{BHE} , INST, HSO pins, PWM/P2.5, CLKOUT, RESET, Ports 3 and 4, TXD/P2.0 and RXD (in serial mode 0). The V_{OH} specification is not valid for RESET. Ports 3 and 4 are open-drain outputs.
3. Standard Inputs include HSI pins, READY, BUSWIDTH, NMI, RXD/P2.1, EXTINT/P2.2, T2CLK/P2.3 and T2RST/P2.4.
4. Maximum current per pin must be externally limited to the following values if V_{OL} is held above 0.45V or V_{OH} is held below $V_{CC} - 0.7V$:

- I_{OL} on Output pins: 10 mA
- I_{OH} on quasi-bidirectional pins: self limiting
- I_{OH} on Standard Output pins: 10 mA

5. Maximum current per bus pin (data and control) during normal operation is ± 3.2 mA.

6. During normal (non-transient) conditions the following total current limits apply:

Port 1, P2.6	I_{OL} : 29 mA	I_{OH} is self limiting
HSO, P2.0, RXD, \overline{RESET}	I_{OL} : 29 mA	I_{OH} : 26 mA
P2.5, P2.7, WR, \overline{BHE}	I_{OL} : 13 mA	I_{OH} : 11 mA
AD0-AD15	I_{OL} : 52 mA	I_{OH} : 52 mA
\overline{RD} , ALE, INST-CLKOUT	I_{OL} : 13 mA	I_{OH} : 13 mA

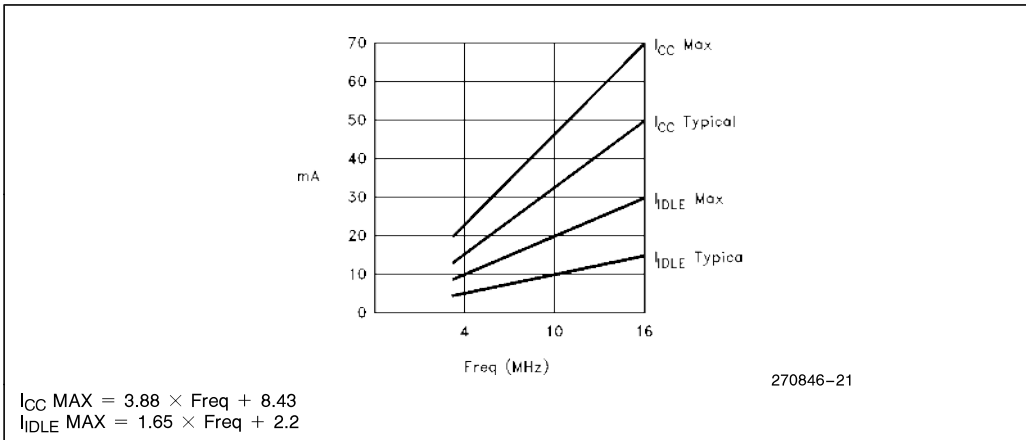

Figure 5. I_{CC} and I_{IDLE} vs Frequency

AC CHARACTERISTICS

For use over specified operating conditions.

Test Conditions: Capacitive load on all pins = 100 pF, Rise and fall times = 10 ns, F_{OSC} = 16 MHz

The system must meet these specifications to work with the 87C196KC:

Symbol	Description	Min	Max	Units	Notes
T _{AVYV}	Address Valid to READY Setup		2 T _{OSC} - 75	ns	
T _{LLYV}	ALE Low to READY Setup		T _{OSC} - 70	ns	
T _{YLYH}	Non READY Time	No upper limit		ns	
T _{CLYX}	READY Hold after CLKOUT Low	0	T _{OSC} - 30	ns	(Note 1)
T _{LLYX}	READY Hold after ALE Low	T _{OSC} - 15	2 T _{OSC} - 40	ns	(Note 1)
T _{AVGV}	Address Valid to Buswidth Setup		2 T _{OSC} - 75	ns	
T _{LLGV}	ALE Low to Buswidth Setup		T _{OSC} - 60	ns	
T _{CLGX}	Buswidth Hold after CLKOUT Low	0		ns	
T _{AVDV}	Address Valid to Input Data Valid		3 T _{OSC} - 55	ns	(Note 2)
T _{RLDV}	\overline{RD} Active to Input Data Valid		T _{OSC} - 30	ns	(Note 2)
T _{CLDV}	CLKOUT Low to Input Data Valid		T _{OSC} - 50	ns	
T _{RHDZ}	End of \overline{RD} to Input Data Float		T _{OSC}	ns	
T _{RDX}	Data Hold after \overline{RD} Inactive	0		ns	

NOTES:

1. If max is exceeded, additional wait states will occur.
2. If wait states are used, add 2 T_{OSC} * N, where N = number of wait states.



AC CHARACTERISTICS (Continued)

For use over specified operating conditions.

Test Conditions: Capacitive load on all pins = 100 pF, Rise and fall times = 10 ns, $F_{OSC} = 16$ MHz**The 87C196KC will meet these specifications:**

Symbol	Description	Min	Max	Units	Notes
F _{XTAL}	Frequency on XTAL ₁	4.0	16	MHz	(Note 1)
T _{OSC}	1/F _{XTAL}	62.5	250	ns	
T _{XHCH}	XTAL1 High to CLKOUT High or Low	20	110	ns	
T _{CLCL}	CLKOUT Cycle Time	2 T _{OSC}		ns	
T _{CHCL}	CLKOUT High Period	T _{OSC} - 10	T _{OSC} + 15	ns	
T _{CLLH}	CLKOUT Falling Edge to ALE Rising	-5	15	ns	
T _{LLCH}	ALE Falling Edge to CLKOUT Rising	-20	+15	ns	
T _{LHLH}	ALE Cycle Time	4 T _{OSC}		ns	(Note 4)
T _{LHLL}	ALE High Period	T _{OSC} - 10	T _{OSC} + 10	ns	
T _{AVLL}	Address Setup to ALE Falling Edge	T _{OSC} - 15			
T _{LLAX}	Address Hold after ALE Falling Edge	T _{OSC} - 40		ns	
T _{LLRL}	ALE Falling Edge to \overline{RD} Falling Edge	T _{OSC} - 30		ns	
T _{RLCL}	\overline{RD} Low to CLKOUT Falling Edge	0	35	ns	
T _{RLRH}	\overline{RD} Low Period	T _{OSC} - 5		ns	(Note 4)
T _{RHLH}	\overline{RD} Rising Edge to ALE Rising Edge	T _{OSC}	T _{OSC} + 25	ns	(Note 2)
T _{RLAZ}	\overline{RD} Low to Address Float		5	ns	
T _{LLWL}	ALE Falling Edge to \overline{WR} Falling Edge	T _{OSC} - 10		ns	
T _{CLWL}	CLKOUT Low to \overline{WR} Falling Edge	0	25	ns	
T _{QVWH}	Data Stable to \overline{WR} Rising Edge	T _{OSC} - 30			(Note 4)
T _{CHWH}	CLKOUT High to \overline{WR} Rising Edge	-10	15	ns	
T _{WLWH}	\overline{WR} Low Period	T _{OSC} - 30		ns	(Note 4)
T _{WHQX}	Data Hold after \overline{WR} Rising Edge	T _{OSC} - 25		ns	
T _{WHLH}	\overline{WR} Rising Edge to ALE Rising Edge	T _{OSC} - 10	T _{OSC} + 15	ns	(Note 2)
T _{WHBX}	\overline{BHE} , INST after \overline{WR} Rising Edge	T _{OSC} - 10		ns	
T _{WHAX}	AD8-15 HOLD after \overline{WR} Rising	T _{OSC} - 30		ns	(Note 3)
T _{RHBX}	\overline{BHE} , INST after \overline{RD} Rising Edge	T _{OSC} - 10		ns	
T _{RHAX}	AD8-15 HOLD after \overline{RD} Rising	T _{OSC} - 30		ns	(Note 3)

NOTES:

1. Testing performed at 4.0 MHz. However, the device is static by design and will typically operate below 1 Hz.
2. Assuming back-to-back bus cycles.
3. 8-Bit bus only.
4. If wait states are used, add 2 T_{OSC} * N, where N = number of wait states.

System Bus Timings

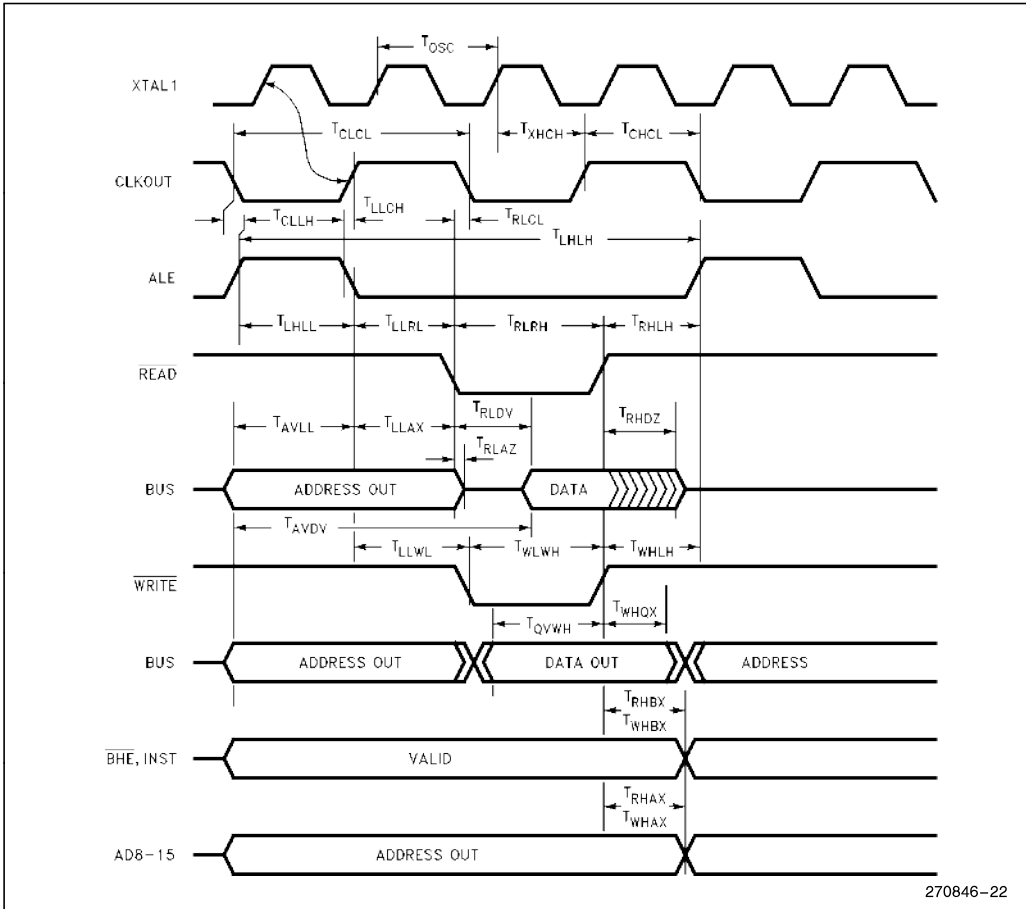

READY Timings (One Waitstate)

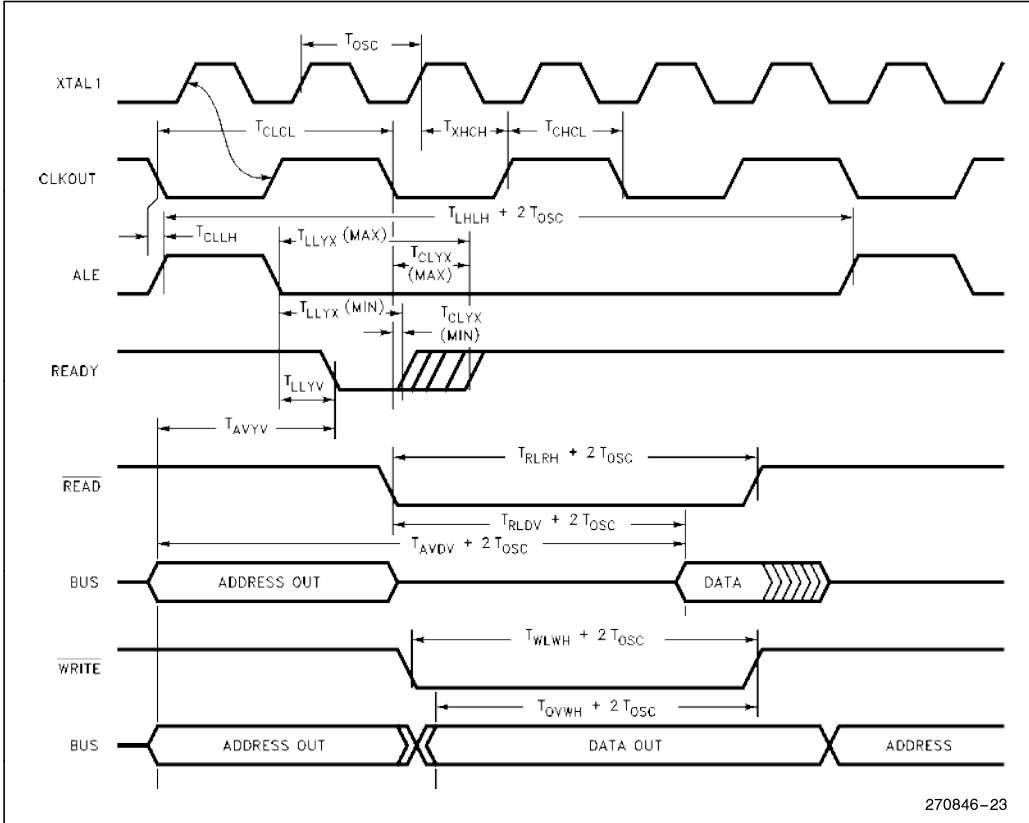

Buswidth Timings

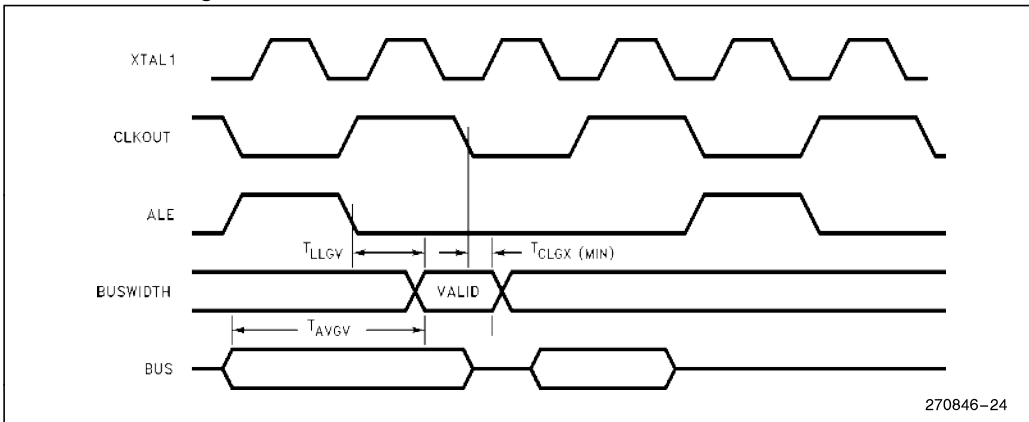

HOLD/HLDA Timings

Symbol	Description	Min	Max	Units	Notes
T _{HVCH}	HOLD Setup	55		ns	(Note 1)
T _{CLHAL}	CLKOUT Low to HLDA Low	-15	15	ns	
T _{CLBRL}	CLKOUT Low to BREQ Low	-15	15	ns	
T _{AZHAL}	HLDA Low to Address Float		15	ns	
T _{BZHAL}	HLDA Low to BHE, INST, RD, WR Weakly Driven		15	ns	
T _{CLHAH}	CLKOUT Low to HLDA High	-15	15	ns	
T _{CLBRH}	CLKOUT Low to BREQ High	-15	15	ns	
T _{HAHAX}	HLDA High to Address No Longer Float	-15		ns	
T _{HAHBV}	HLDA High to BHE, INST, RD, WR Valid	-10		ns	
T _{CLLH}	CLKOUT Low to ALE High	-5	15	ns	

NOTE:

1. To guarantee recognition at next clock.

DC SPECIFICATIONS IN HOLD

	Min	Max	Units
Weak Pullups on \overline{ADV} , \overline{RD} , \overline{WR} , WRL, BHE	50K	250K	$V_{CC} = 5.5V, V_{IN} = 0.45V$
Weak Pulldowns on ALE, INST	10K	50K	$V_{CC} = 5.5V, V_{IN} = 2.4$

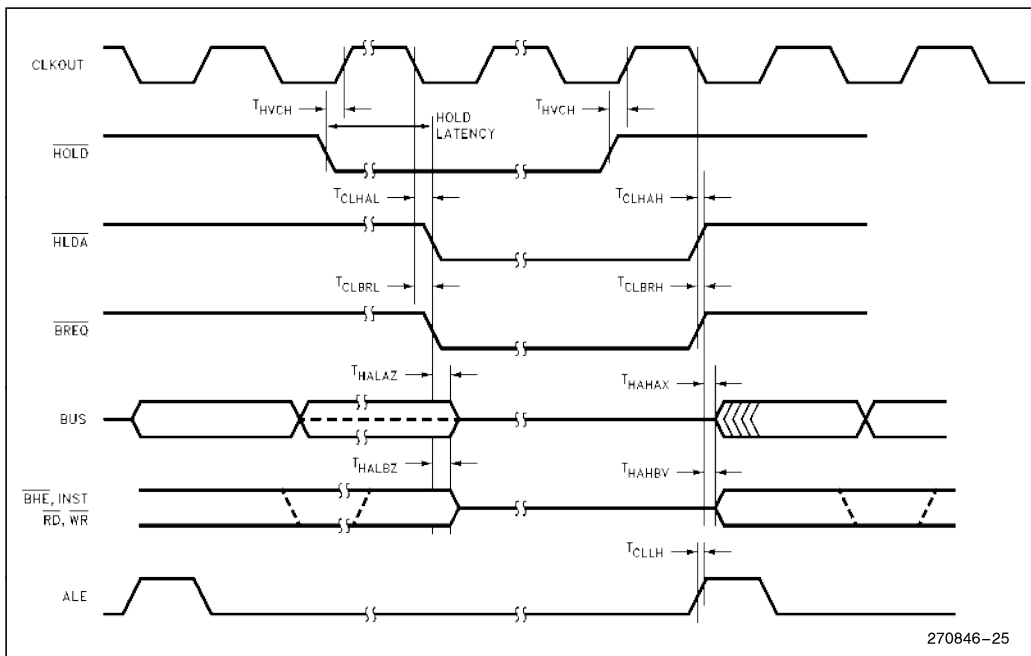

EXTERNAL CLOCK DRIVE

Symbol	Parameter	Min	Max	Units
1/T _{XLXL}	Oscillator Frequency	4.0	16.0	MHz
T _{XLXL}	Oscillator Frequency	62.5	250	ns
T _{XHXX}	High Time	22		ns
T _{XLXX}	Low Time	22		ns
T _{XLXH}	Rise Time		10	ns
T _{XHXL}	Fall Time		10	ns

EXTERNAL CLOCK DRIVE WAVEFORMS

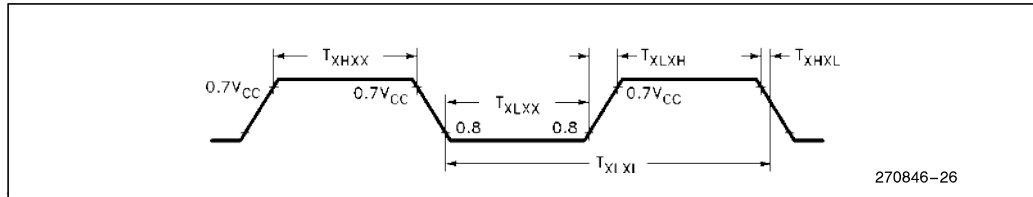

An external oscillator may encounter as much as a 100 pF load at XTAL1 when it starts-up. This is due to interaction between the amplifier and its feedback capacitance. Once the external signal meets the V_{IL} and V_{IH} specifications, the capacitance will not exceed 20 pF.

AC TESTING INPUT, OUTPUT WAVEFORMS

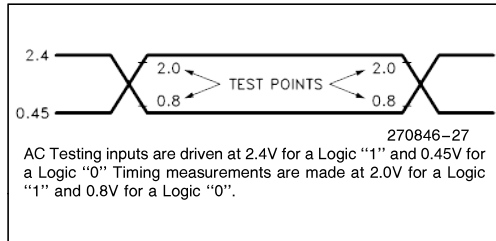

FLOAT WAVEFORMS

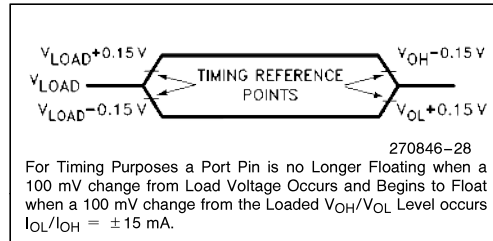

EXPLANATION OF AC SYMBOLS

Each symbol is two pairs of letters prefixed by "T" for time. The characters in a pair indicate a signal and its condition, respectively. Symbols represent the time between the two signal/condition points.

Conditions:

- H— High
- L— Low
- V— Valid
- X— No Longer Valid
- Z— Floating

Signals:

- A— Address
- B— BHE
- C— CLKOUT
- D— DATA
- G— Buswidth
- H— HOLD
- HA— HLDA

L— ALE/ \overline{ADV}

BR— \overline{BREQ}

R— \overline{RD}

W— $\overline{WR}/\overline{WRH}/\overline{WRL}$

X— XTAL1

Y— READY

Q— Data Out

AC CHARACTERISTICS—SERIAL PORT—SHIFT REGISTER MODE

SERIAL PORT TIMING—SHIFT REGISTER MODE

Symbol	Parameter	Min	Max	Units
T _{XLXL}	Serial Port Clock Period (BRR ≥ 8002H)	6 T _{OSC}		ns
T _{XLXH}	Serial Port Clock Falling Edge to Rising Edge (BRR ≥ 8002H)	4 T _{OSC} - 50	4 T _{OSC} + 50	ns
T _{XLXL}	Serial Port Clock Period (BRR = 8001H)	4 T _{OSC}		ns
T _{XLXH}	Serial Port Clock Falling Edge to Rising Edge (BRR = 8001H)	2 T _{OSC} - 50	2 T _{OSC} + 50	ns
T _{QVXH}	Output Data Setup to Clock Rising Edge	2 T _{OSC} - 50		ns
T _{XHQX}	Output Data Hold after Clock Rising Edge	2 T _{OSC} - 50		ns
T _{XHQV}	Next Output Data Valid after Clock Rising Edge		2 T _{OSC} + 50	ns
T _{DVXH}	Input Data Setup to Clock Rising Edge	T _{OSC} + 50		ns
T _{XHDX}	Input Data Hold after Clock Rising Edge	0		ns
T _{XHQZ}	Last Clock Rising to Output Float		1 T _{OSC}	ns

WAVEFORM—SERIAL PORT—SHIFT REGISTER MODE

SERIAL PORT WAVEFORM—SHIFT REGISTER MODE

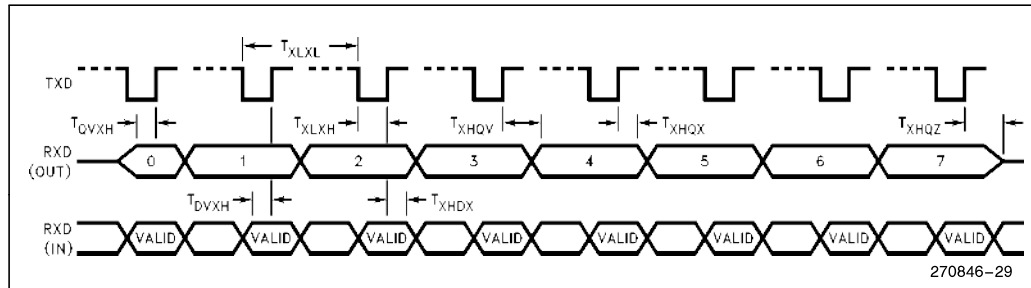

270846-29

EPROM SPECIFICATIONS

AC EPROM Programming Characteristics

Operating Conditions: Load Capacitance = 150 pF, $T_A = +25^\circ\text{C} \pm 5^\circ\text{C}$, V_{CC} , $V_{REF} = 5\text{V}$, V_{SS} , $ANGND = 0\text{V}$, $V_{PP} = 12.50\text{V} \pm 0.25\text{V}$, $EA = 12.50\text{V} \pm 0.25\text{V}$

Symbol	Description	Min	Max	Units
T_{SHLL}	Reset High to First $\overline{\text{PALE}}$ Low	1100		T_{OSC}
T_{LLH}	$\overline{\text{PALE}}$ Pulse Width	50		T_{OSC}
T_{AVLL}	Address Setup Time	0		T_{OSC}
T_{LLAX}	Address Hold Time	100		T_{OSC}
T_{PLDV}	$\overline{\text{PROG}}$ Low to Word Dump Valid		50	T_{OSC}
T_{PHDX}	Word Dump Data Hold		50	T_{OSC}
T_{DVPL}	Data Setup Time	0		T_{OSC}
T_{PLDX}	Data Hold Time	400		T_{OSC}
$T_{PLPH}^{(2)}$	$\overline{\text{PROG}}$ Pulse Width	50		T_{OSC}
T_{PHLL}	$\overline{\text{PROG}}$ High to Next $\overline{\text{PALE}}$ Low	220		T_{OSC}
T_{LHPL}	$\overline{\text{PALE}}$ High to $\overline{\text{PROG}}$ Low	220		T_{OSC}
T_{PHPL}	$\overline{\text{PROG}}$ High to Next $\overline{\text{PROG}}$ Low	220		T_{OSC}
T_{PHIL}	$\overline{\text{PROG}}$ High to $\overline{\text{AINC}}$ Low	0		T_{OSC}
T_{ILIH}	$\overline{\text{AINC}}$ Pulse Width	240		T_{OSC}
T_{ILVH}	$\overline{\text{PVER}}$ Hold after $\overline{\text{AINC}}$ Low	50		T_{OSC}
T_{ILPL}	$\overline{\text{AINC}}$ Low to $\overline{\text{PROG}}$ Low	170		T_{OSC}
T_{PHVL}	$\overline{\text{PROG}}$ High to $\overline{\text{PVER}}$ Valid		220	T_{OSC}

NOTES:

- Run Time Programming is done with $F_{OSC} = 6.0\text{ MHz to }12.0\text{ MHz}$, $V_{REF} = 5\text{V} \pm 0.50\text{V}$, $T_A = +25^\circ\text{C to } \pm 5^\circ\text{C}$ and $V_{PP} = 12.50\text{V}$. For run-time programming over a full operating range, contact the factory.
- This specification is for the Word Dump Mode. For programming pulses, use $300 T_{OSC} + 100 \mu\text{s}$.

DC EPROM Programming Characteristics

Symbol	Description	Min	Max	Units
I_{PP}	V_{PP} Supply Current (When Programming)		100	mA

NOTE:

V_{PP} must be within 1V of V_{CC} while $V_{CC} < 4.5\text{V}$. V_{PP} must not have a low impedance path to ground of V_{SS} while $V_{CC} > 4.5\text{V}$.



EPROM PROGRAMMING WAVEFORMS

SLAVE PROGRAMMING MODE DATA PROGRAM MODE WITH SINGLE PROGRAM PULSE

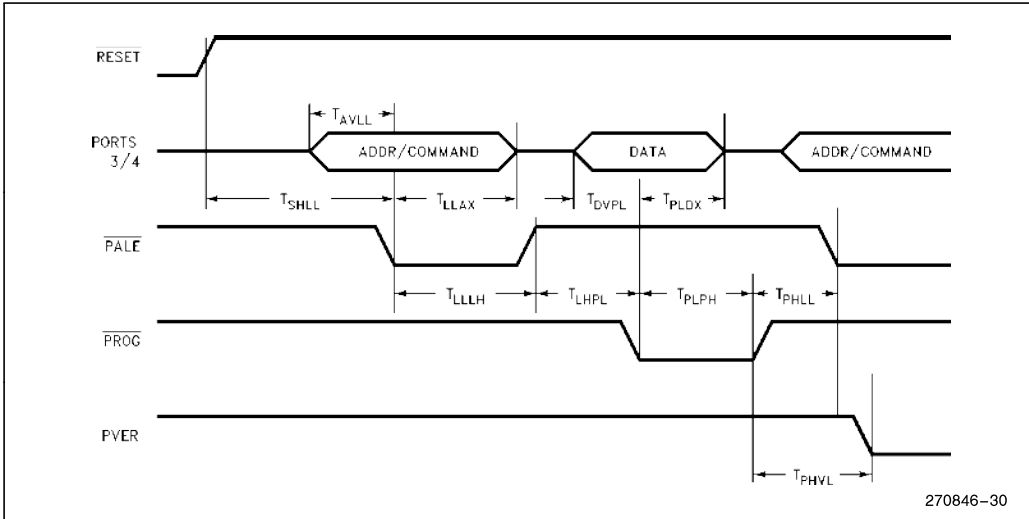

SLAVE PROGRAMMING MODE IN WORD DUMP WITH AUTO INCREMENT

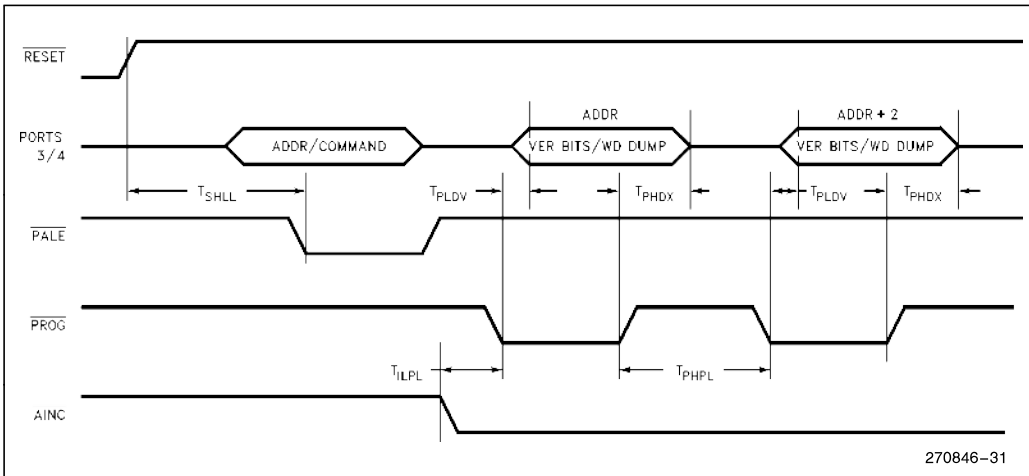

SLAVE PROGRAMMING MODE TIMING IN DATA PROGRAM WITH REPEATED PROG PULSE AND AUTO INCREMENT

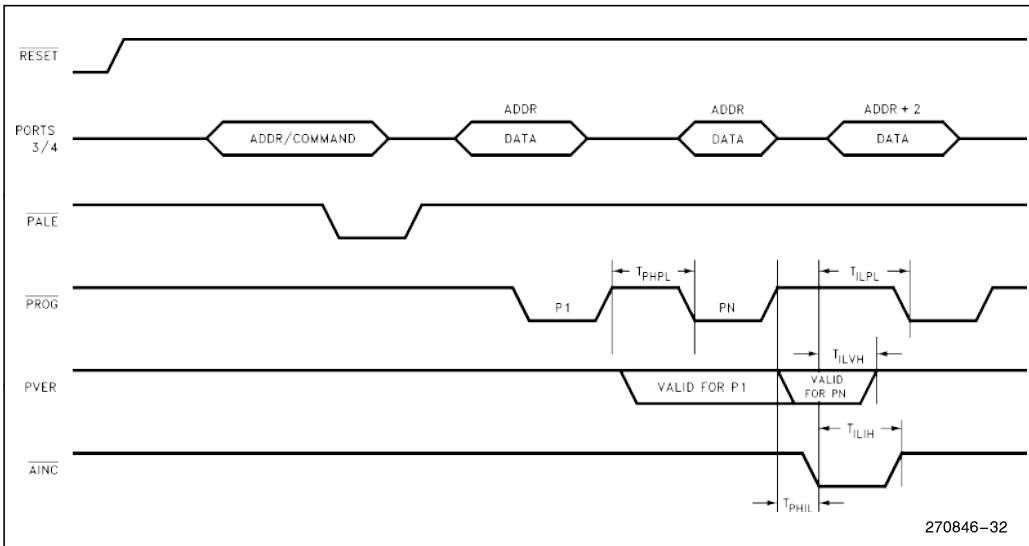

10-BIT A/D CHARACTERISTICS

The speed of the A/D converter in the 10-bit mode can be adjusted by setting a clock prescaler on or off. At high frequencies more time is needed for the comparator to settle. The maximum frequency with the clock prescaler disabled is 6 MHz. The conversion times with the prescaler turned on or off is shown in the table below. The AD_TIME register has not been characterized for the 10-bit mode.

The converter is ratiometric, so the absolute accuracy is dependent on the accuracy and stability

of V_{REF} . V_{REF} must be close to V_{CC} since it supplies both the resistor ladder and the digital section of the converter.

A/D CONVERTER SPECIFICATIONS

The specifications given below assume adherence to the Operating Conditions section of this data sheet. Testing is performed with $V_{REF} = 5.12V$.

Clock Prescaler On IOC2.4 = 0	Clock Prescaler Off IOC2.4 = 1
156.5 States 19.5 μs @ 16 MHz	89.5 States 29.8 μs @ 6 MHz

Parameter	Typical (3)	Minimum	Maximum	Units*	Notes
Resolution		1024 10	1024 10	Levels Bits	
Absolute Error		0	± 4	LSBs	
Full Scale Error	± 3			LSBs	
Zero Offset Error	± 3			LSBs	
Non-Linearity		0	± 4	LSBs	
Differential Non-Linearity Error		> -1	+2	LSBs	
Channel-to-Channel Matching		0	± 1	LSBs	
Repeatability	± 0.25			LSBs	
Temperature Coefficients:					
Offset	0.009			LSB/°C	
Full Scale	0.009			LSB/°C	
Differential Non-Linearity	0.009			LSB/°C	
Off Isolation		-60		dB	1, 2
Feedthrough	-60			dB	1
V_{CC} Power Supply Rejection	-60			dB	1
Input Resistance		750	1.2K	Ω	
DC Input Leakage		0	3.0	μA	
Sample Time: Prescaler On	16			States	
Prescaler Off	8			States	
Input Capacitance	3			pF	

NOTES:

- *An "LSB", as used here, has a value of approximately 5 mV.
- 1. DC to 100 KHz.
- 2. Multiplexer Break-Before-Make Guaranteed.
- 3. Typical values are expected for most devices at 25°C.



8-BIT MODE A/D CHARACTERISTICS

The 8-bit mode trades off resolution for a faster conversion time. The AD_TIME register must be used when performing an 8-bit conversion.

Sample Time 20 States	Convert Time 56 States
A6H in AD_TIME 9.8 μs @ 16 MHz	

The following specifications are tested @ 16 MHz with OA6H in AD_TIME. The actual AD_TIME register is tested with all possible values, to ensure functionality, but the accuracy of the A/D converter is not.

Parameter	Typical	Minimum	Maximum	Units*	Notes
Resolution		256 8	256 8	Levels Bits	
Absolute Error		0	±2	LSBs	
Full Scale Error	±1			LSBs	
Zero Offset Error	±2			LSBs	
Non-Linearity		0	±2	LSBs	
Differential Non-Linearity Error		> -1	+1	LSBs	
Channel-to-Channel Matching			±1	LSBs	
Repeatability	±0.25			LSBs	
Temperature Coefficients:					
Offset	0.003			LSB/°C	
Full Scale	0.003			LSB/°C	
Differential Non-Linearity	0.003			LSB/°C	

NOTES:

*An "LSB", as used here, has a value of approximately 20 mV.
1. Typical values are expected for most devices at 25°C.

8XC196KB TO 87C196KC DESIGN CONSIDERATIONS

1. Memory Map. The 87C196KC has 512 bytes of RAM/SFRs and 16K of ROM/EPROM. The extra 256 bytes of RAM will reside in locations 100H–1FFH and the extra 8K of EPROM will reside in locations 4000H–5FFFH. These locations are external memory on the 87C196KB.
2. The CDE pin on the KB has become a V_{SS} pin on the KC to support 16 MHz operation.
3. EPROM programming. The 87C196KC has a different programming algorithm to support 16K of on-board memory. When performing Run-Time Programming, use the section of code on page 99 of the 80C196KC User's Guide, Order Number 270704.

4. ONCE Mode Entry. The ONCE mode is entered on the 87C196KC by driving the TXD pin low on the rising edge of RESET. The TXD pin is held high by a pullup that is specified at 1.4 mA and remain at 2.0V. This Pullup must not be overridden or the 87C196KC will enter the ONCE mode.
5. During the bus HOLD state, the 87C196KC weakly holds RD, WR, ALE, BHE and INST in their inactive states. The 87C196KB only holds ALE in its inactive state.
6. A RESET pulse from the 87C196KC is 16 states rather than 4 states as on the 87C196KB (i.e., a watchdog timer overflow). This provides a longer RESET pulse for other devices in the system.



87C196KC B-3 STEP ERRATA

1. NMI during PTS skips an address: When an NMI interrupts a PTS routine, the first byte of the instruction following completion of the PTS cycle is lost. This results in incorrect code execution. Workaround: NMI must be disabled using external hardware during any PTS activity.
2. QBD port glitch. There is a strong negative glitch on all QBD Port pins (P1.x and P2.6, P2.7) synchronous with the first falling edge of CLKOUT. This glitch lasts about 10 ns, and only occurs one time following the initial application of V_{CC}. The time for the pin to return to V_{CC} may be several microseconds, depending on pin loading capacitance. Workaround: External systems and devices should be disabled from responding to this glitch until after the first CLKOUT falling edge has occurred.
3. Divide error during HOLD or READY. The result of a signed divide instruction may be off by one if executed while the device is held off the bus by HOLD or READY and the queue is empty. Specific timings of HOLD or READY going active or inactive must be met. Workaround for HOLD: disable HOLD during signed divide operations (using hardware or software). Workaround for READY: problem will only occur if unlimited wait state mode is selected, and 14 or more wait states are inserted.
4. The HSI unit has two errata: one dealing with resolution and the other with first entries into the FIFO.

The HSI resolution is 9 states instead of 8 states. Events on the same line may be lost if they occur faster than once every 9 state times.

There is a mismatch between the 9 state time HSI resolution and the 8 state time timer. This causes one time value to be unused every 9 timer counts.

Events may receive a time-tag on one count later than expected because of this “skipped” time value.

If the first two events into an empty FIFO (not including the Holding Register) occur in the same internal phase, both are recorded with one time-tag. Otherwise, if the second event occurs within 9 states after the first, its time-tag is one count later than the first time tag. If this is the “skipped” time value, the second event’s time-tag is 2 counts later than the first’s.

If the FIFO and Holding Register are empty, the first event will transfer into the Holding Register after 8 state times, leaving the FIFO empty again. If the second event occurs after this time, it will act as a new first event into an empty FIFO.

DATASHEET REVISION HISTORY

The following are the key differences between this datasheet and the -003/-004 version:

1. The “advanced information” status was dropped and replaced with production status (no label).
2. Trademarks were updated.
3. Product prefix variables are now indicated with an x

