

PTC04

Programmer for Melexis PTC Devices

1. Features

- Universal programming utility
- Fast development
- Fast plug-in for software applications
- Atmega128 Core
- Firmware updatable via RS232 and USB
- FPGA updatable via RS232 and USB
- 3 High Current Programmable Supplies
- 1 High Speed Fast Programmable Supply
- 16 bit Level Settings
- 16 bit differential Measurements
- 4 analog comparators
- Vector Generator
- I2C to Daughter Board
- Mountable in 19" Rack

2. Application Examples

- Experimental tool for Lab and Prototyping
- Production Equipment for Serial Programming
- Programming tool for characterization



3. Ordering information

Product Code	Description
PTC04	Programmer Unit (Full Set: Including adapter, cables, software)
PTC04-DB-HALL01	Daughter Board 1 st generation Linear Hall sensors products
PTC04-DB-HALL03	Daughter Board 2 nd generation Linear Hall and current Sensors
PTC04-DB-HALL04	Daughter Board PSI5 interface products
PTC04-DB-HALL05	Daughter Board Current sensor products
PTC04-DB-90316	Daughter Board Triaxis sensor products
PTC04-DB-HALL06	Daughter Board 2 nd and 3 rd generation Triaxis and Linear sensor products
PTC04-DB-PRESSURE01	Daughter Board Pressure sensors products
PTC04-DB-SPI	Daughter Board SPI interface products
PTC04-DB-FastLoader	Daughter Board LIN interface products
PTC04-DB-922xx	Daughter Board Latch and Switch products
PTC04-DB-xxxxx	Other Daughter Boards for future products
PTC04-19-x (with x equal to 1 till 2)	19" Rack with build in x number of PTC04

4. Accessories

Product Code	Description
Software Environment MPT (Windows)	Including Calibration Software and update tools
DLL for Mini-Tester (Windows)	
DLL's for all supported products (Windows)	
User Interface for most support products (Windows)	

5. Functional Diagram

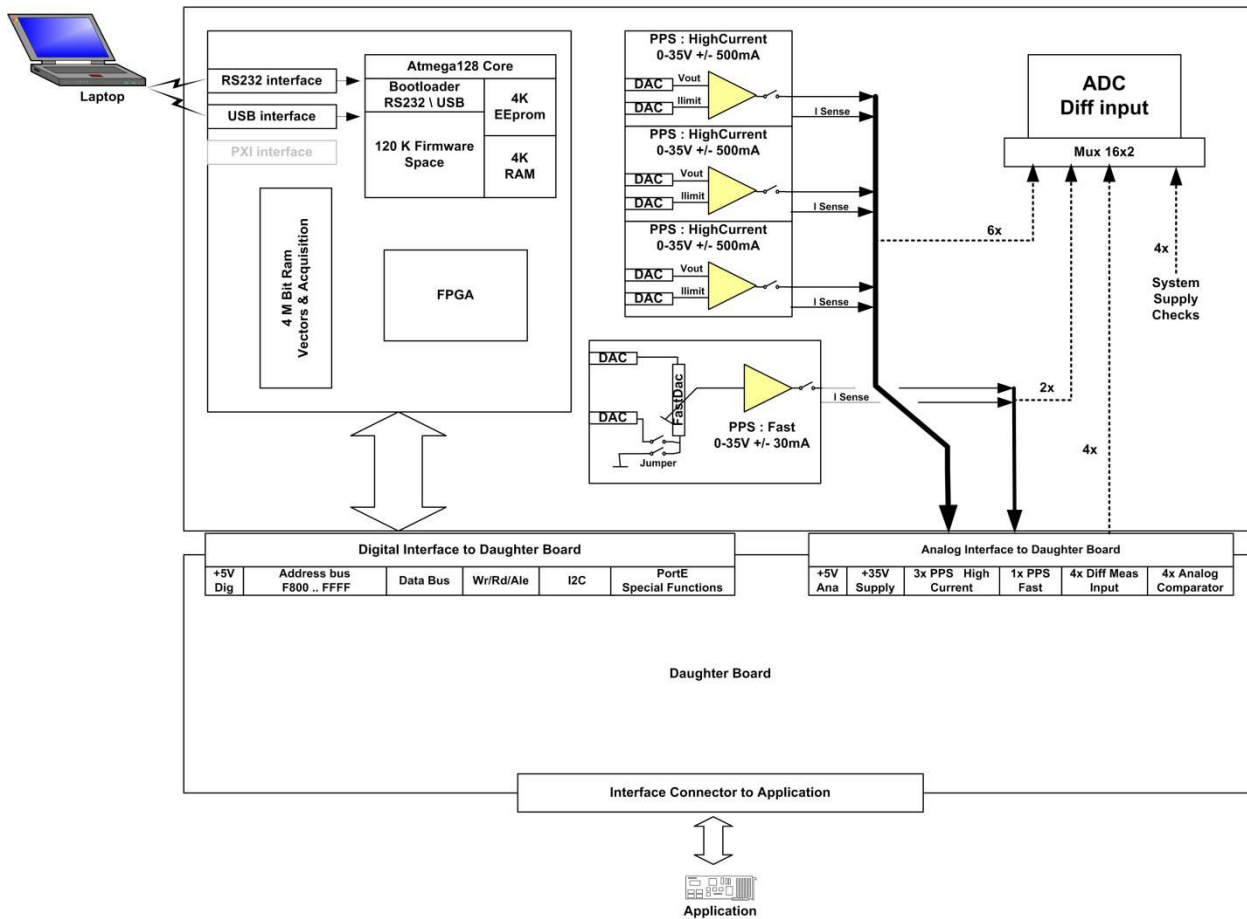

Figure 5-1 PTC04 Functional Block Diagram

6. General Description

The PTC-04 programmer was designed for efficient, precise calibration of the Melexis families of programmable ICs. The programmer is designed to be easily adapted to a standard PC and to an application module to allow calibration of programmable sensor ICs within the operating environment. The PTC-04 programmer contains its own programmable power supply and measurement circuitry. The programmer is similar to a standard EEPROM programmer, but adds many special features such as 16 bit voltage and current measurement capability, and configuration options that will accommodate users from the prototyping phase directly into production. An IBM compatible PC is required (not included) to load software to the programmer and control the functions of the programmer.

Communication is done through a standard RS-232 null modem cable to a COM port of the PC or via USB. The PC requires no custom configuration, allowing the programmer to be used with any PC with a COM port speed of 115.2kbs or a standard USB 1.1 or USB 2.0 interface

7. Contents

1. Features.....	1
2. Application Examples.....	1
3. Ordering information.....	1
4. Accessories	1
5. Functional Diagram	2
6. General Description.....	2
7. Contents	3
8. Glossary of Terms.....	5
9. Absolute Maximum Ratings.....	5
10. PTC04 Electrical Specifications	5
10.1. System Power Supply.....	5
10.2. Programmable High Current Power Supply 1-3	6
10.3. Programmable Fast Power Supply.....	6
11. Measurement System	7
12. Function Timings	7
13. Unique Features	8
13.1. Mini-Tester.....	8
13.2. Analogue Vector Generator.....	8
13.3. Acquisition memory.....	8
13.4. Port E Atmega128.....	8
14. Main Board Description.....	9
14.1. Board Layout.....	9
14.2. Power Supplies.....	9
14.3. Power Supply System Check.....	10
14.4. Supply Connector.....	10
14.5. LED Indicators	10
14.6. USB Connector	10
14.7. RS 232 Connector	10
14.8. Reset button	11
14.9. Daughter board Connectors	11
14.9.1. Digital DB Connector (40 Pins).....	12
14.9.2. Analog DB Connector (48 Pins).....	13

- 15. Daughter board concept 13**
 - 15.1. Background 13
 - 15.2. Requirements..... 13
- 16. RS 232 Communication with host 14**
 - 16.1. Connector..... 14
 - 16.2. Cable..... 14
 - 16.3. Settings..... 14
- 17. USB Communication with host..... 15**
 - 17.1. Connectors 15
 - 17.2. Cable..... 15
 - 17.3. Settings..... 15
- 18. Measurement system..... 16**
 - 18.1. Channels..... 16
 - 18.2. Conversion time 16
 - 18.3. Accuracy..... 16
- 19. Application Information..... 17**
- 20. FAQ..... 17**
- 21. Mechanical Outlines 18**
- 22. ESD Precautions..... 20**
- 23. Contact 20**
- 24. Disclaimer 21**

8. Glossary of Terms

PTC04	The programmer (including the applicable DB)
DB	Daughter board
PTC	Program Through Connector
PPS	Programmable Power Supply
MPT	Melexis Programmable Toolbox
PSF	Product specific function library (DLL)
DLL	Dynamic-link library

9. Absolute Maximum Ratings

Parameter		Value	Units
Supply Voltage (External input)	$V_{S\ EXT}$	48.2	V
Reverse Voltage Protection		Yes	
Supply Current	$I_S\ Fused$	1	A
PPS 1,2,3 Output voltage	V_{PPS}	34	V
PPS 1,2,3 Output Current (peak value)	I_{PPS}	500	mA
PPS 4 Output Current (peak value)	I_{PPS}	50	mA
Operating Temperature Range	T_A	35	°C
Storage Temperature Range	T_S	0°C – 55	°C

Table 1: Absolute maximum ratings

Exceeding the absolute maximum ratings may cause permanent damage. Exposure to absolute maximum rated conditions for extended periods may affect device reliability.

10. PTC04 Electrical Specifications

10.1. System Power Supply

DC Operating Parameters $T_A = 25-35^\circ\text{C}$, $V_{ext} = 48\text{V}$ (unless otherwise specified)

Parameter	Symbol	Test Conditions	Min	Typ	Max	Units
DC System Power Supply	V_{ext_in}		23	48	48.2	V
System Current Consumption	I_{Ext_in}		0.1		1.2	A
Daughter Board Analog Power Supply *				500	36	V mA
Daughter Board Digital Power Supply				5 500		V mA

Table 2: General electrical parameters

*Depends on DC System Power Supply

10.2. Programmable High Current Power Supply 1-3

DC Operating Parameters $T_A = 25-35^{\circ}\text{C}$, $V_{\text{ext}} = 48\text{V}$ (unless otherwise specified)

Parameter	Symbol	Test Conditions	Min	Typ	Max	Units
Output voltage range *	VPPS 1-3	Unloaded	0.62		34.00	V
Output resolution				0.52		mV
Output Current (peak value)	IPPS 1-3		-500		500	mA
Current Limit range	I limPPS 1-3		-500		500	mA
Settling time		Unloaded	10		20	uS
Voltage Source Swing PPS1-PPS3	Vout	I out = 10mA	0.035		34	V
		I out = 100mA	0.2		32.5	V
		I out = 500mA	1.15		26	V
		I out = -10mA	1.14		34	V
		I out = -100mA	2.3		30	V
		I out = -500mA	9.46		30	V
Voltage Source Accuracy		PPS1-3, I out = 10mA	-1		+1	%
			-1.05		+1.05	mV
Voltage Source Slew Rate		PPS1-3, C load = 100nF	2.5			V/uS
		PPS1-3, C load = 1uF	0.5			
		Between 20 & 80%				

Table 3: Programmable High Current Power Supply 1-3

*Depends on the DC System Power Supply

10.3. Programmable Fast Power Supply

DC Operating Parameters $T_A = 25-35^{\circ}\text{C}$, $V_{\text{ext}} = 48\text{V}$ (unless otherwise specified)

Parameter	Symbol	Test Conditions	Min	Typ	Max	Units
Output voltage range	VPPS 4	When Fast DAC = 255	0.37		13	V
Output resolution				0.2		mV
Output Current (peak value)	IPPS 4		-20		20	mA
Fast DAC resolution		Divider between Pos and Neg voltage		8		bits
Settling time		This is taken by changing the Fast DAC only	0.5		5	uS
Voltage Source Swing PPS4	Vout	I out = 10mA	1		13	V
		I out = 50mA	0.5		10	
Voltage Source Accuracy		PPS4, I out = 10mA	-1		+1	%
			-0.8		+0.8	mV
Voltage Source Slew Rate Using 8 bit Fast DAC		PPS4, C load = 100nF	0.25			V/uS
		PPS4, C load = 1uF	0.08			
		Between 20 & 80%				

Table 4: Programmable Fast Power Supply

11. Measurement System

DC Operating Parameters $T_A = 25-35^{\circ}\text{C}$, $V_{\text{ext}} = 48\text{V}$ (unless otherwise specified)

Parameter	Symbol	Test Conditions	Min	Typ	Max	Units
ADC Channels				16		
Pin Potential			-0.5		35.5	V
Voltage range (full mode)			-37.5		37.5	V
Resolution (full Mode)				1.15		mV
Accuracy (full Mode)			-0.1		+0.1	%
			-1.15		+1.15	mV
Voltage range (fine mode)			-7.8		7.8	V
Resolution (fine Mode)				0.24		mV
Accuracy (fine Mode)			-0.1		+0.1	%
			-0.25		0.25	mV
Current Meter Range		PPS1-3	-500		500	mA
		PPS4	-50		50	
Resolution (full Mode)		PPS1-3		77		uA
		PPS4		52		
Current Meter Accuracy		PPS1-3	-2		+2	%
			-0.312		0.312	mA
		PPS4	-2		+2	%
			-0.5		0.5	mA

Table 5: Programmable Fast Power Supply

12. Function Timings

DC Operating Parameters $T_A = 25-35^{\circ}\text{C}$, $V_{\text{ext}} = 48\text{V}$ (unless otherwise specified)

Parameter	Symbol	Test Conditions	Min	Typ	Max	Units
Voltage Source Program Rate		PPS1-4, Using PC Software and RS232 interface		20		mS
		Using vector functions		10		uS
Voltage Source Noise		PPS1-4, Peak-to-peak		2	5	mV
Current Measurement Sample Time		Firmware Only		0.5		mS
		PC software and RS232		20		

Table 6: Function Timings

13. Unique Features

13.1. Mini-Tester

Due to the architecture of the Hardware in combination with the Software, the PTC04 can be used as a mixed mode tester (With limited performance).

There are library routines (DLL) available in order to interface with any software language. (C++, Visual Basic, Lab view, Excel (VBA)...))

13.2. Analogue Vector Generator

A vector space of 512Kbyte allows you to store a huge amount of actions. These actions consist of setting a level on a channel, waiting a time x, setting the Fast DAC and making samples on an analogue input (measurement) or a digital comparator. For details, refer to the PSF of the PTC04 chapter Pattern functions.

13.3. Acquisition memory

An advance library on the Analogue vector generators, allows use of the vector area in combination with Measurement and setting levels. Through this method one may use the PTC04 as a slow Data acquisition card.

13.4. Port E Atmega128

The port E of the Atmega128 core is connected fully to the Daughter board.

With this port, items like critical timing generation measurements can be performed. Also, all types of UARTS can be configured. Other capabilities are possible with the PTC04.

For more details, refer to the Atmega128 datasheet.

14. Main Board Description

14.1. Board Layout

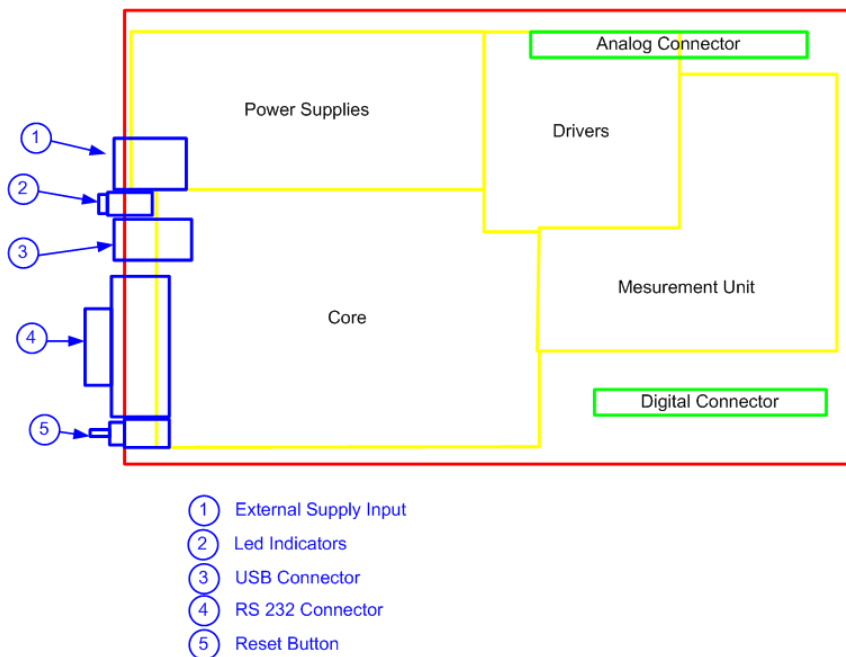

Figure 14-1

As shown in Figure14-1, The Main board can be divided in 4 major areas.

- The Supplies where all required voltage and current levels are created
- The digital Core that processes all requests from the host computer
- A Driver Area where the Programmable Power supplies are located
- A Measurement area where the ADC and the input MUX are located

Beside these four areas, there are the input connector on the main board and the two connectors to the daughter board.

14.2. Power Supplies

The Power Supply input connector is a single input to supply the whole PTC. The Input supply requires a minimum of 24 volts and can tolerate a maximum of 48 volts. It is not recommended to use a higher voltage than needed for the application. There's an internal fuse (on the main board) of 1 A in order to avoid damage when improperly used. The connected supply should provide a minimum current of 1.5 A with peak capacity to source 10A.

The external Supply is the source to create all the internal requirements. Internal voltages are created on the main board by using the input voltage from the external supply.

- +35V for drivers (for the drivers or Programmable Power Supplies)
- +5V Digital (Digital core as interface between PTC and Host application)
- +5V Analog (measurement circuit with MUX and ADC)
- +3.3 V Digital (Supply for the FPGA and USB)

14.3. Power Supply System Check

When something goes wrong it's useful to check the status of all the above mentioned supplies.

The main board has the capability to measure all internal supplies. The only requirement is that the +5V Digital supply is available. This is indicated by the red led on the rear panel of the programmer.

All the other supply could be checked by the Measurement system itself. Channels 8 till 11 are reserved for this. The channel 8 is connected to the driver supply and is very useful to check the voltages of the connected external supply. This can be useful to check when applications are launched where extra high voltage is needed. Refer to the chapter "Measurement system" for more details about measuring these channels. There are DLL functions available that will do these checks for you.

A typical diagnostic check will start with checking if the external supply is available. Then it will check if the red led is lit. If these steps are ok, the diagnostics via software can be executed.

14.4. Supply Connector

This connector provides the PTC with power. Either the power connector on the front or on the back side of the PTC04 can be used.

Any power source that generates a voltage between 24 and 48 V DC with a minimum current of 1.5 A is allowed.



Figure 14-2

14.5. LED Indicators



Two Led indicators will help the user to check the status of the PTC

The red led shows that the core inside has power

The green led will show a busy status. If the Programmer is executing a job, the led will be on.

Figure 14-3

14.6. USB Connector

One of the communication possibilities with the host PC is the USB link.

See chapter "USB communication with host" for more details

14.7. RS 232 Connector

One of the communication possibilities with the host PC is the serial Communication.

See chapter "RS communication with host" for more details

14.8. Reset button

This button is connected to all reset lines in the main board as well as on the daughterboard. This button allows the user to reset the whole programmer after crashing software and when connected also to the application device under test.

14.9. Daughter board Connectors

The main board has two connectors to the interface with the application. The PTC allows the addition of a full PCB in between the main board and the interface. This daughter board can be mounted on the two connectors. In some exceptional cases, a daughter board contains only a few wires from the Analog connector to the application connector.

The connectors are described below.

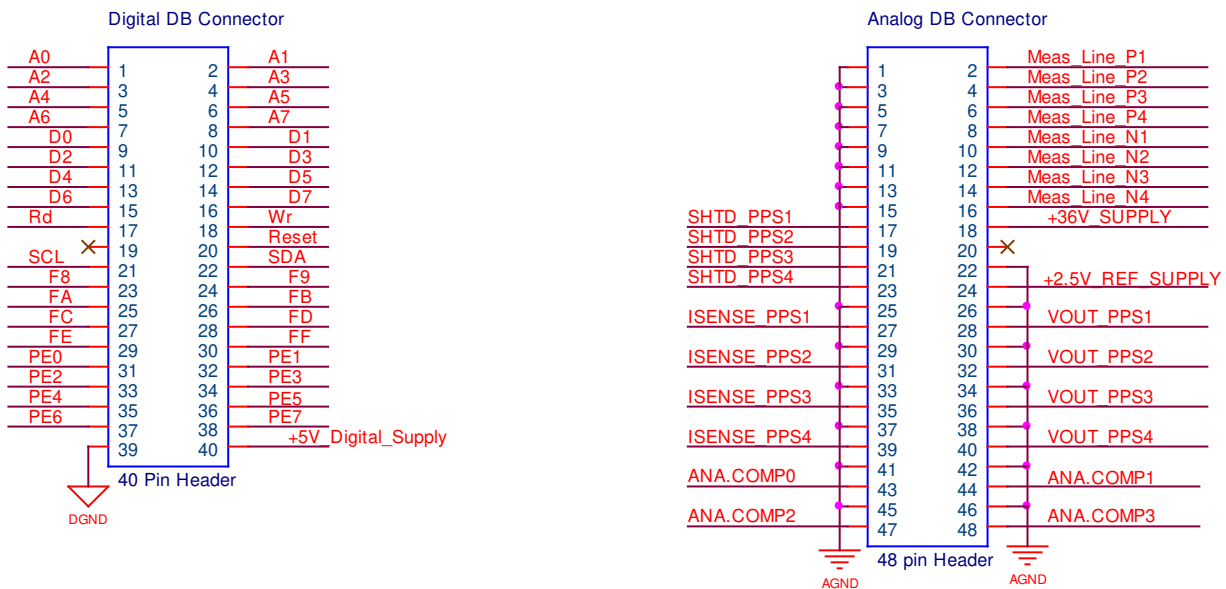

Figure 14-4: Daughter Board Connectors

14.9.1. Digital DB Connector (40 Pins)

Mainly, the digital connector is meant to expand the programmer for extra needs. Address lines A0-A7 together with the Map Select Lines F8-FF allows the user direct access to an area of 2 K. Example would be adding a simple addressed I/O register by using the selection lines. If more complexity is needed, a full FPGA can be mounted on the DB board.

Pins	Names	Description
1 – 8	A0 – A7	Address lines
9 – 16	D0 – D7	Data Lines active during Rd or Wr signals
17	Rd	Read : A negative pulse will indicate a sampling of the data on the Data Bus
18	Wr	Write : A Negative pulse will indicate when data is available on the Data Bus
20	Reset	This signal goes low by powering the PTC or by pressing the reset button. This line can be pulled low by application. Check firmware documentation for resetting by software.
21-22	SCL / SDA	I2c Bus
23-30	F8,F9,...,FF	CS lines when the address areas are accessed
31-38	Port E	Note: These pins are limited to 5 Volt input\output. The full Port E of the Atmega core is mounted to these pins. This allows us to use advanced features like PWM, UARTS, Time Measurements, etc. By using firmware that supports these functions, really nice application specific requirements can be fulfilled.
39	DGND	Digital Ground
40	+5V Digital	5 Volt Digital Supply. Maximum current to get out of this supply :mA

Table 7: Digital daughter board connector

Note: All the pins are limited to 5 Volt input\output. However, there are protections, please take precautions in order to avoid damage to the main board.

14.9.2. Analog DB Connector (48 Pins)

Mainly, the analog connector provides all the analog signals and measure possibilities.

Pins	Names	Description
28,32,36	PPS 1-3	Output of the Programmable Supplies
40	PPS 4	Output of the Fast DAC Programmable Power Supply
27,31,35,39	Isense_PP1-4	Outputs (Driver outputs before Rsens) for current evaluations. These outputs could be used to connect to the analog comparators in order to create fast digital signals based on current.
2,4,6,8	ExtMeas1-4Pos	There are 4 differential inputs for making measurements
10,12,14,16	ExtMeas1_4Neg	The negative inputs of ExtMeas1-4Pos
17,19,21,23	Shtd_PPS1-4	Outputs that show the status of the Drivers. Signals are meant to connect LED's for the front panel
43,44,47,48	AnaComp0-3	See *Note. Input (limited to 5V) Fast Level comparators in order to remove time consuming measurement
18	+35V_Supply	Supply to extend the daughter board with some extra drivers
20	NC	Not Connected
24	+2.5V Ref	Output of internal reference
All other	AGND	Analog Ground

Table 8: Analog daughter board connector

Note: All the pins are limited to 35 Volt input/output! However, there are protections, please take precautions in order to avoid damage of the main board.

** Note: Some pins are protected and limited to 5 Volt! However, there are protections, please take precautions in order to avoid damage of the main board.*

15. Daughter board concept

15.1. Background

The future of our products is not known and building a universal programmer will not be possible to survive more than a few years. For this reason, a flexibility is built in by having a Daughter board (abbreviation: DB) as interface between PTC04 and the application connector. On this way, special needs can be fulfilled. The simplest DB is just wires form the DB connectors to the application connector. The idea is to support with one single DB as many as possible products.

15.2. Requirements

See specific daughter board documentation.

16. RS 232 Communication with host

This page describes all items concerning the hardware of the RS232C communication link.

Information about the protocol is explained in the software documentation.

16.1. Connector

DB9-Male	Description
2	RxD
3	TxD
5	GND

Table 9: RS232 connection

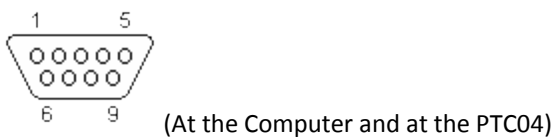

9 PIN D-SUB MALE at the Computer.

16.2. Cable

The cable between PTC and Host PC is a standard null-modem cable for RS232C Cable Description:

DB9-FEM	DB9 FEM	Description
2	3	RxD / TxD
3	2	TxD / RxD
5	5	GND

Table 10: RS232 cable

16.3. Settings

The microprocessor core has a fixed setting to communicate with the host.

Used settings are as follows:

Parameter	Value
Baud rate	115, 2 kbps
Bits	8
Parity	No
Flow Control	None
Stop bits	1

Table 11: RS232 settings

17. USB Communication with host

Universal Serial Bus (USB) is used (V1.0)

Developed by Compaq, Hewlett-Packard, Intel, Lucent, Microsoft, NEC and Phillips.

17.1. Connectors

Pin	Name	Description
1	VBUS	+5 VDC
2	D-	Data -
3	D+	Data+
4	GND	Ground

Table 12: USB connection

17.2. Cable

Default:



USB A (at the Connector) to plug into a PC



USB B (at the Connector) to plug into the PTC04

Series "A" plugs are used towards the host system and series "B" plugs are used towards the USB device.

17.3. Settings

Two drivers have to be installed and are available in one executable on the Software CD.

18. Measurement system

The measurement system on the main board contains mainly a high accurate 16 bit ADC and two 16 to 1 channels MUX. Basically, the ADC always measures differential between inputs.

For the internal voltage channels, the negative input is the internal analog ground.

For the current measurements that use a sense resistor (PPS1-4) are clearly measuring over the sense resistor.

There are also 4 full differential lines going to the daughter board allowing the user to make high quality measurements by selecting the reference by the application itself. This way of working easily supports the use of force and sense lines.

18.1. Channels

Nr.	Pos Input	Neg Input	Description
0	Vout PPS1	Internal AGND	Output Voltage PPS1
1	V driver PPS1	Vout PPS1	Output Current PPS1
2	Vout PPS2	Internal AGND	Output Voltage PPS2
3	V driver PPS2	Vout PPS2	Output Current PPS2
4	Vout PPS3	Internal AGND	Output Voltage PPS3
5	V driver PPS3	Vout PPS3	Output Current PPS3
6	Vout PPS4	Internal AGND	Output Voltage PPS4
7	V driver PPS4	Vout PPS4	Output Current PPS4
8	Supply Driver: +35/2	Internal AGND	Driver Supply divide by 2
9	Supply Analog : +5 V	Internal AGND	Analog 5V Supply
10	Supply Digital : +5 V	Internal AGND	Digital 5V Supply
11	Reference : +2.5V	Internal AGND	Reference Voltage for DAC\ADC
12	DB_Ana_conn Pin 2	DB_Ana_conn Pin 10	Daughterboard Meas. Channel 1
13	DB_Ana_conn Pin 4	DB_Ana_conn Pin 12	Daughterboard Meas. Channel 2
14	DB_Ana_conn Pin 6	DB_Ana_conn Pin 14	Daughterboard Meas. Channel 3
15	DB_Ana_conn Pin 8	DB_Ana_conn Pin 16	Daughterboard Meas. Channel 4

Table 13: ADC measurement channels

18.2. Conversion time

In general the conversion time depends on the loaded firmware version. Theoretically, a full conversion to a floating real value takes about 4ms if the filter is put at 100 samples.

18.3. Accuracy

To preserve the accuracy of the PTC04, Melexis recommends checking the tolerance of the PTC04 once a year.

19. Application Information

When using the PTC04 in combination with external equipment or other PTC04's, it is very important to have a good solid earth/ground connection on the different appliances. A bad earth/ground connection on appliances and the PTC04 can cause damage to the PTC04. The measuring unit and the digital channels of the PTC04 are sensitive to level shifts.

The metal case of the PTC04 has to be connected to the earth connection of the power grid via the frame connection or via the earth connection on the back panel of the PTC04.

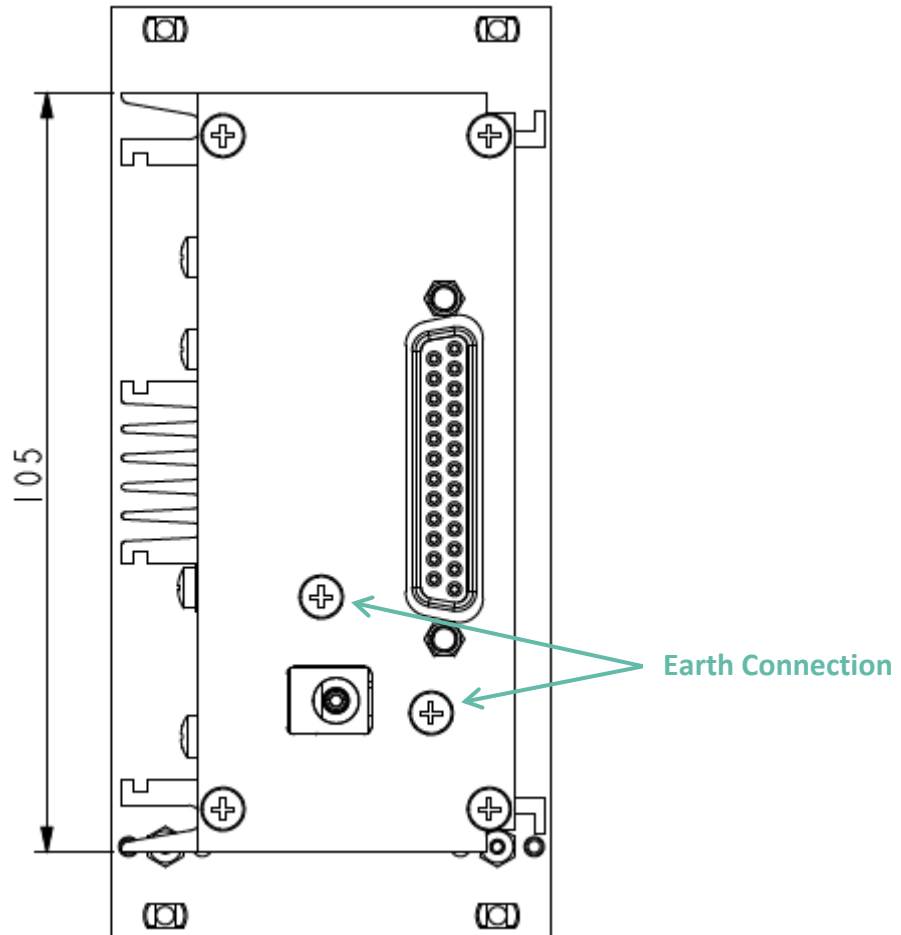

When using the PTC04 for End Of Line calibration of a Melexis product, it is mandatory to use qualified reference equipment for the End Of Line verification of the programmed/calibrated product.

20. FAQ

Please refer to the document [FAQ_PTC04.pdf](#)

21. Mechanical Outlines

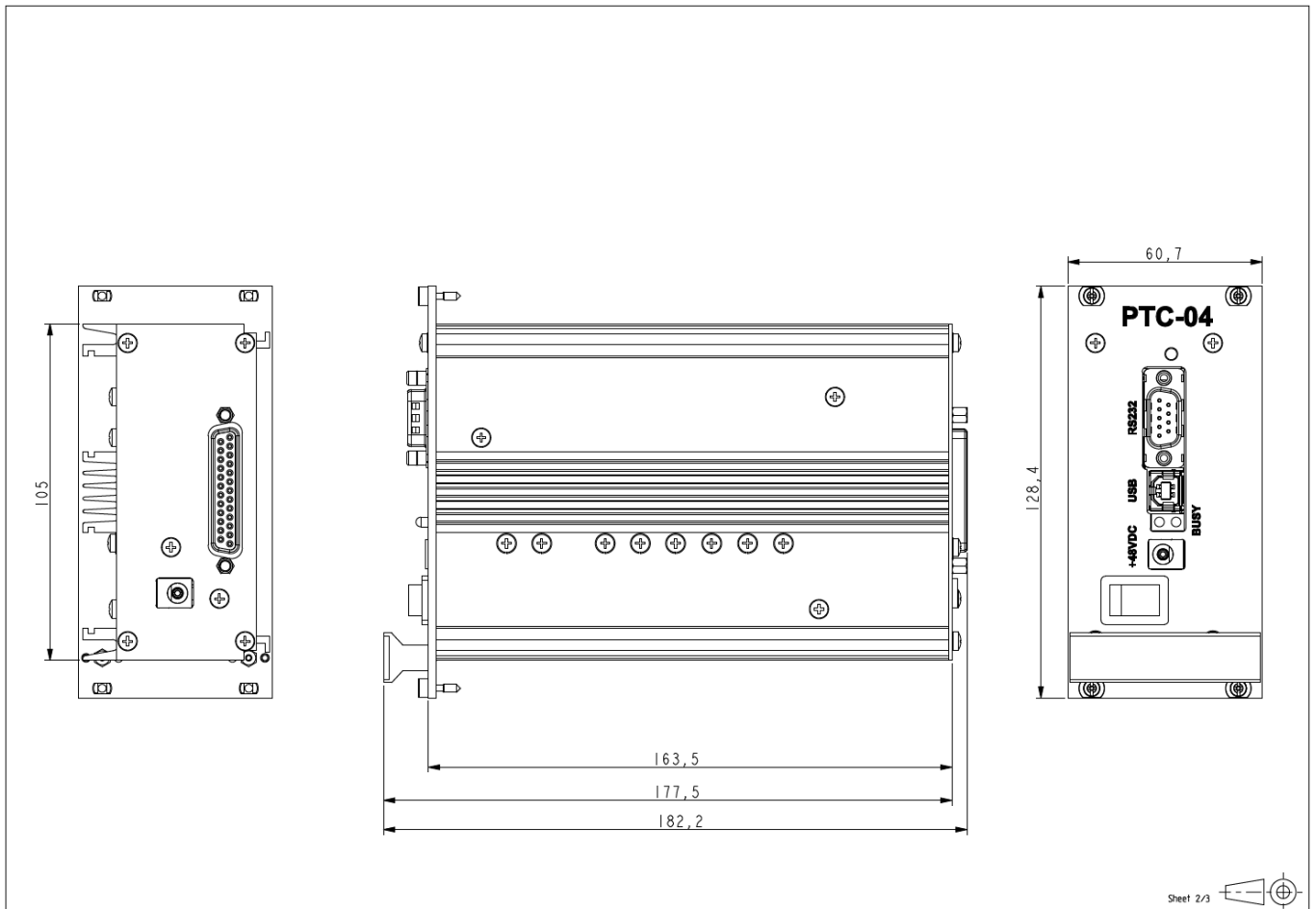
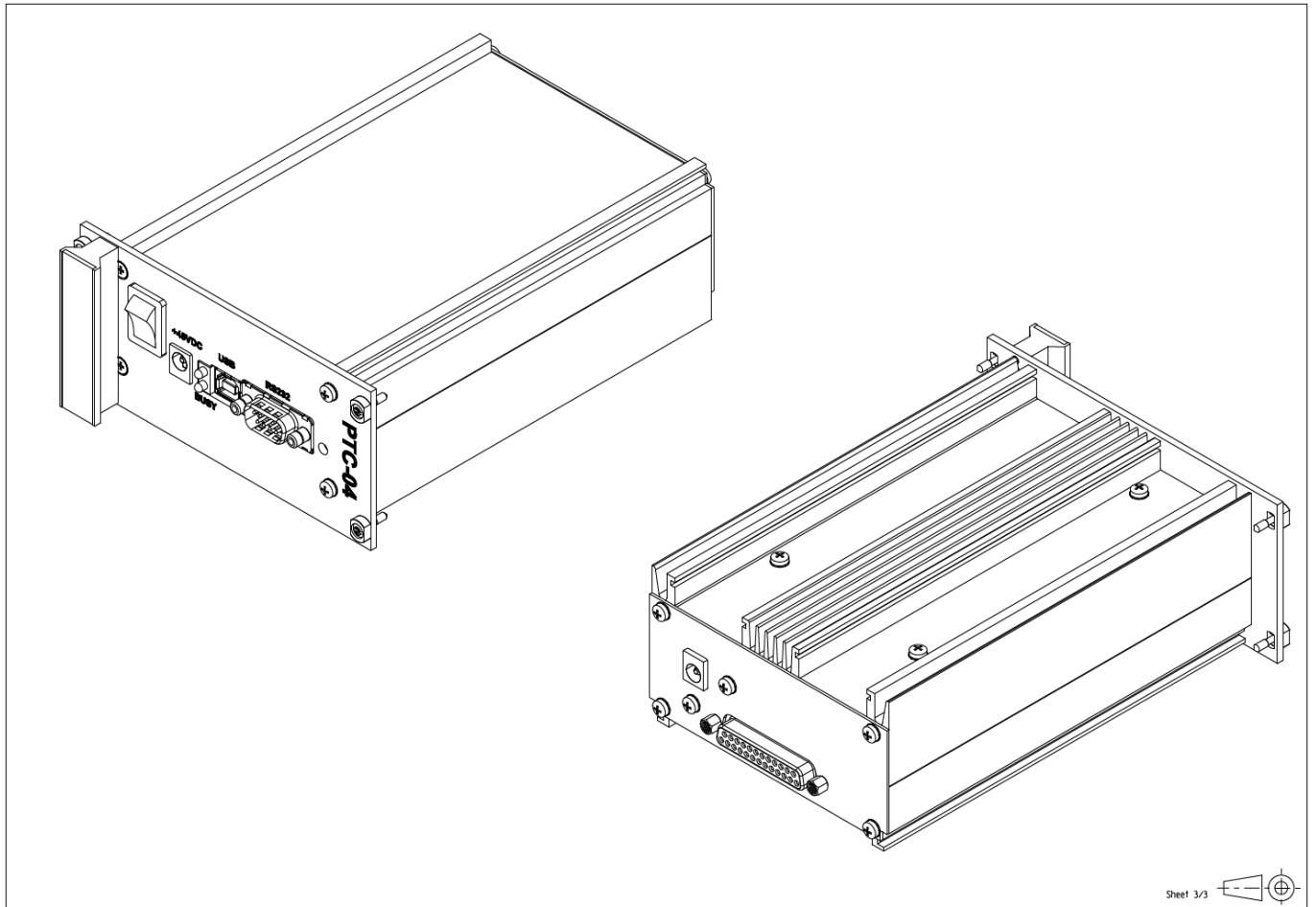

Figure 21-1: Mechanical Outlines



Sheet 3/3

Figure 21-2: Mechanical 3D View

22. ESD Precautions

Electronic semiconductor products are sensitive to Electro Static Discharge (ESD).

Always observe Electro Static Discharge control procedures whenever handling semiconductor products.

23. Contact

For the latest version of this document, go to our website at www.melexis.com.

For additional information, please contact our Direct Sales team and get help for your specific needs:

Europe, Africa	Telephone: +32 13 67 04 95
	Email : sales_europe@melexis.com
Americas	Telephone: +1 603 223 2362
	Address: Melexis NV, Rozendaalstraat 12, 8900 Ieper
	Email : sales_usa@melexis.com
Asia	Email : sales_asia@melexis.com

24. Disclaimer

The content of this document is believed to be correct and accurate. However, the content of this document is furnished "as is" for informational use only and no representation, nor warranty is provided by Melexis about its accuracy, nor about the results of its implementation. Melexis assumes no responsibility or liability for any errors or inaccuracies that may appear in this document. Customer will follow the practices contained in this document under its sole responsibility. This documentation is in fact provided without warranty, term, or condition of any kind, either implied or expressed, including but not limited to warranties of merchantability, satisfactory quality, non-infringement, and fitness for purpose. Melexis, its employees and agents and its affiliates' and their employees and agents will not be responsible for any loss, however arising, from the use of, or reliance on this document. Notwithstanding the foregoing, contractual obligations expressly undertaken in writing by Melexis prevail over this disclaimer.

This document is subject to change without notice, and should not be construed as a commitment by Melexis. Therefore, before placing orders or prior to designing the product into a system, users or any third party should obtain the latest version of the relevant information.

Users or any third party must determine the suitability of the product described in this document for its application, including the level of reliability required and determine whether it is fit for a particular purpose.

This document as well as the product here described may be subject to export control regulations. Be aware that export might require a prior authorization from competent authorities. The product is not designed, authorized or warranted to be suitable in applications requiring extended temperature range and/or unusual environmental requirements. High reliability applications, such as medical life-support or life-sustaining equipment or avionics application are specifically excluded by Melexis. The product may not be used for the following applications subject to export control regulations: the development, production, processing, operation, maintenance, storage, recognition or proliferation of:

- 1. chemical, biological or nuclear weapons, or for the development, production, maintenance or storage of missiles for such weapons;*
- 2. civil firearms, including spare parts or ammunition for such arms;*
- 3. defense related products, or other material for military use or for law enforcement;*
- 4. any applications that, alone or in combination with other goods, substances or organisms could cause serious harm to persons or goods and that can be used as a means of violence in an armed conflict or any similar violent situation.*

No license nor any other right or interest is granted to any of Melexis' or third party's intellectual property rights.

If this document is marked "restricted" or with similar words, or if in any case the content of this document is to be reasonably understood as being confidential, the recipient of this document shall not communicate, nor disclose to any third party, any part of the document without Melexis' express written consent. The recipient shall take all necessary measures to apply and preserve the confidential character of the document. In particular, the recipient shall (i) hold document in confidence with at least the same degree of care by which it maintains the confidentiality of its own proprietary and confidential information, but no less than reasonable care; (ii) restrict the disclosure of the document solely to its employees for the purpose for which this document was received, on a strictly need to know basis and providing that such persons to whom the document is disclosed are bound by confidentiality terms substantially similar to those in this disclaimer; (iii) use the document only in connection with the purpose for which this document was received, and reproduce document only to the extent necessary for such purposes; (iv) not use the document for commercial purposes or to the detriment of Melexis or its customers. The confidentiality obligations set forth in this disclaimer will have indefinite duration and in any case they will be effective for no less than 10 years from the receipt of this document.

This disclaimer will be governed by and construed in accordance with Belgian law and any disputes relating to this disclaimer will be subject to the exclusive jurisdiction of the courts of Brussels, Belgium.

The invalidity or ineffectiveness of any of the provisions of this disclaimer does not affect the validity or effectiveness of the other provisions. The previous versions of this document are repealed.

Melexis © - No part of this document may be reproduced without the prior written consent of Melexis. (2021)

IATF 16949 and ISO 14001 Certified