

Compact Push Type Power Switches

Malaysia

Series: **R1**

Type: **ESB92S**

High reliability type (applicable to wide range purposes)

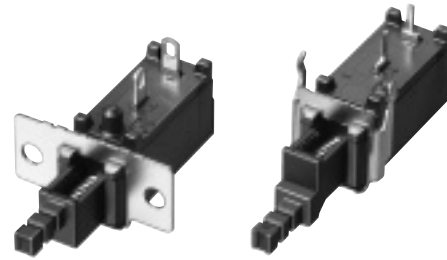

■ Features

- Power switches exclusively for SPST use
- Withstands inrush current up to 128 A
- Special heat resistant structure
- Meets the world's major safety standards
- Rapid switching structure, applicable to IEC60065 6th edition (Refer to the notes.)
- Cadmium-free contact

■ Recommended Applications

- AV Equipment: TVs and audio systems
- OA Equipment: PCs, monitors, printers, etc.

■ Explanation of Part Numbers

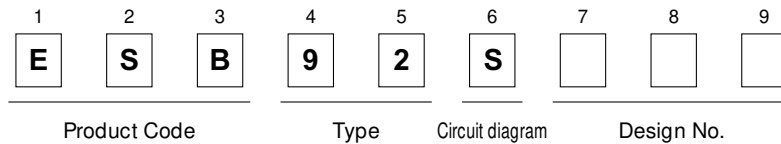

■ Specifications

| | | | |
|-------------------------------|---|-------------|-------------|
| Rating | TV-5, 5 A 250 Vac (UL, CSA) 4 A/128 A 250 Vac (European standards) | | |
| Safety Standards | UL, CSA, VDE, BEAB, SEMKO, FIMKO, SEV, DEMKO, NEMKO | | |
| Circuit Diagram | SPST | | |
| Operating Force | Circuit | Lock Travel | |
| | | 1.5 mm | 2.5 mm |
| | SPST | 6.0 N±2.0 N | 6.0 N±2.0 N |
| Travel | Lock Travel: 2.5 mm, Full Travel: 3.5 mm | | |
| | Lock Travel: 1.5 mm, Full Travel: 2.5 mm | | |
| Minimum Quantity/Packing Unit | 50 pcs. Polyethylene Bag (Bulk) | | |
| Quantity/Carton | 600 pcs. | | |

* OA equipment: PCs, monitors, printers, etc.

Design and specifications are each subject to change without notice. Ask factory for the current technical specifications before purchase and/or use. Should a safety concern arise regarding this product, please be sure to contact us immediately.

■ Dimensions in mm (not to scale)

No. 1

Solder lug type

| Part No. | Travel | | Circuit Diagram |
|-----------|--------|--------|-----------------|
| | Lock | Full | |
| ESB92S27B | 2.5 mm | 3.5 mm | SPST |
| ESB92S17B | 1.5 mm | 2.5 mm | |

* Mounting Spec with M3 Top

No. 2

PWB mount type

| Part No. | Travel | | Circuit Diagram |
|-----------|--------|--------|-----------------|
| | Lock | Full | |
| ESB92S21B | 2.5 mm | 3.5 mm | SPST |
| ESB92S11B | 1.5 mm | 2.5 mm | |

Recommended PWB piercing plan
(t=1.60±0.05)
View from terminal side

■ Dimensions in mm (not to scale)

| Part No. | Travel | | Circuit Diagram |
|-----------|--------|--------|-----------------|
| | Lock | Full | |
| ESB92S81B | 2.5 mm | 3.5 mm | SPST |
| ESB92S94B | 1.5 mm | 2.5 mm | |

No. 3

Solder lug type

(H)=12.5 mm

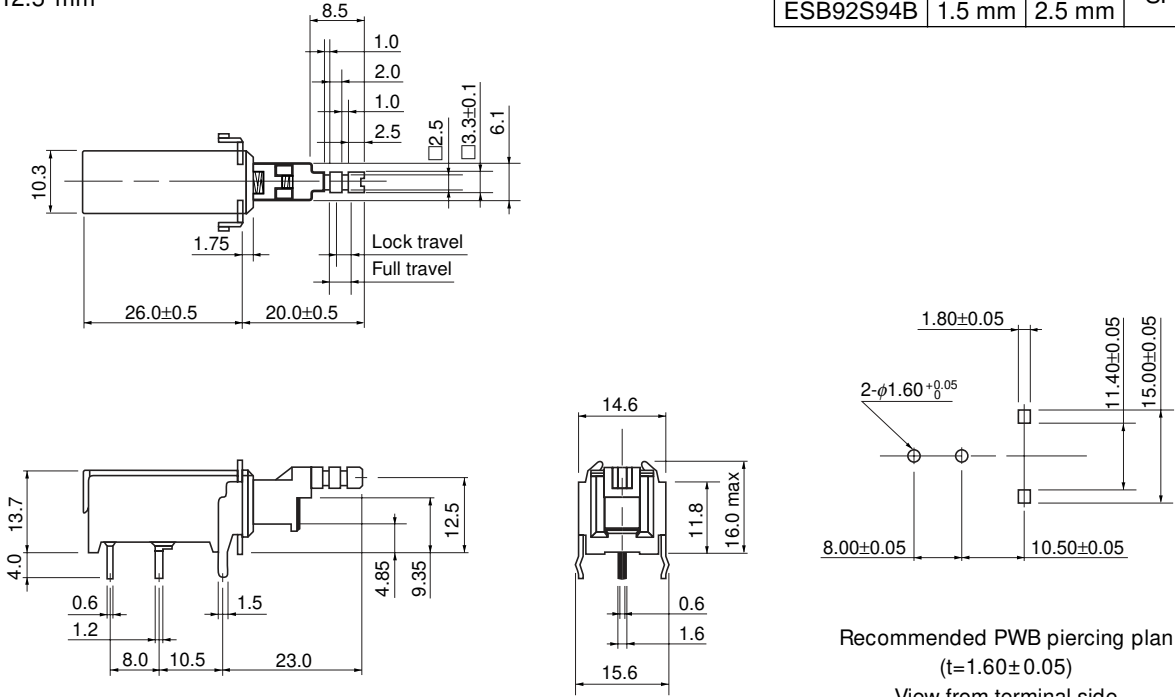

Recommended PWB piercing plan
(t=1.60±0.05)
View from terminal side