



Stereo, 24-Bit, 192kHz 8x Oversampling Digital Interpolation Filter

FEATURES

- COMPANION DIGITAL FILTER FOR THE PCM1704 24-BIT AUDIO DAC
- HIGH PERFORMANCE FILTER:
Stopband Attenuation: -115dB
Passband Ripple: $\pm 0.00005\text{dB}$
- AUDIO INTERFACE:
Input Data Formats: Standard, Left-Justified, and I²S
Input Word Length: 16, 20, or 24 Bits
Output Word Length: 16, 18, 20, or 24 Bits
Sampling Frequency: 32kHz to 192kHz
- SYSTEM CLOCK: 128f_s, 192f_s, 256f_s, 384f_s, 512f_s, 768f_s
- ON-CHIP CRYSTAL OSCILLATOR
- PROGRAMMABLE FUNCTIONS:
Hardware or Software Control Modes
Sharp or Slow Roll-Off Filter Response
Soft Mute
Digital De-Emphasis
Independent Left/Right Digital Attenuation
- +3.3V SINGLE-SUPPLY OPERATION
- SMALL SSOP-28 PACKAGE

DESCRIPTION

The DF1706 is a high performance, stereo, 8X oversampling digital interpolation filter designed for high-end consumer and professional audio applications. The DF1706 supports 24-bit, 192kHz operation and features user-programmable functions, including

selectable filter response, de-emphasis, attenuation, and input/output data formats.

The DF1706 is the ideal companion for Texas Instruments's PCM1704 24-bit audio Digital-to-Analog (D/A) converter. This combination allows for the construction of very high-performance audio systems and components.

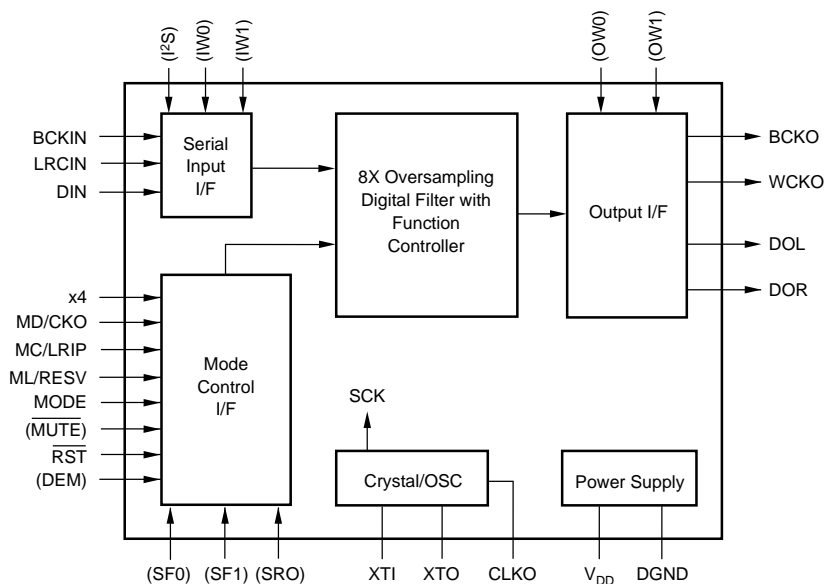

SPECIFICATIONS

All specifications at $T_A = +25^\circ\text{C}$, $V_{DD} = 3.3\text{V}$, $f_S = 44.1\text{kHz}$, system clock = $256f_S/384f_S$, 16-bit data, unless otherwise noted.

PARAMETER	CONDITIONS	DF1706E			UNITS
		MIN	TYP	MAX	
RESOLUTION		24			Bits
INPUT DATA FORMAT Audio Data Interface Format Audio Data Bit Length Audio Data Format Sampling Frequency System Clock Frequency ⁽¹⁾	f_S	Standard, Left-Justified, I ² S 16, 20, 24 Selectable MSB First, Binary Two's Complement 32 192 128/192/256/384/512/768			kHz f_S
OUTPUT DATA FORMAT Audio Data Interface Format Audio Data Bit Length Audio Data Format		Right-Justified 16, 20, 24 Selectable MSB First, Binary Two's Complement			
DIGITAL INPUT/OUTPUT Input Logic Level: V_{IH} V_{IL} Output Logic Level: V_{OH} V_{OL}	$I_{OH} = 2\text{mA}$ $I_{OL} = 4\text{mA}$	$0.7V_{DD}$ 2.4	CMOS Compatible	$0.3V_{DD}$ 1.0	V V V V
CLKO AC CHARACTERISTICS⁽²⁾ Rise Time Fall Time Duty Cycle ⁽²⁾	t_R t_F 20% to 80% V_{DD} , 20pF 80% to 20% V_{DD} , 20pF 20pF Load		4 3 50		ns ns %
DIGITAL FILTER PERFORMANCE Filter Characteristics 1 (Sharp Roll-Off) Passband Stopband Passband Ripple Stopband Attenuation Filter Characteristics 2 (Slow Roll-Off) Passband Ripple Stopband Passband Ripple Stopband Attenuation Delay Time De-Emphasis Error	$\pm 0.00005\text{dB}$ -3dB Stopband = $0.546f_S$ $\pm 0.0001\text{dB}$ -3dB Stopband = $0.748f_S$	0.546 -115 0.732 -100	 45.125/ f_S	0.454 0.493 ± 0.00005 0.254 0.460 ± 0.0001 ± 0.004	f_S f_S f_S dB dB f_S f_S f_S dB dB dB sec dB
POWER-SUPPLY REQUIREMENTS Voltage Range Supply Current Power Dissipation	V_{DD} $V_{DD} = 3.3\text{V}$ $V_{DD} = 3.3\text{V}$	3.0	3.3 30 99	3.6 45 149	VDC mA mW
TEMPERATURE RANGE Operation Storage Thermal Resistance, θ_{JA}	SSOP-28	-25 -55	100	+85 +125	$^\circ\text{C}$ $^\circ\text{C}$ $^\circ\text{C}$

NOTES: (1) Refer to Table I. (2) Crystal resonator used.

PIN CONFIGURATION

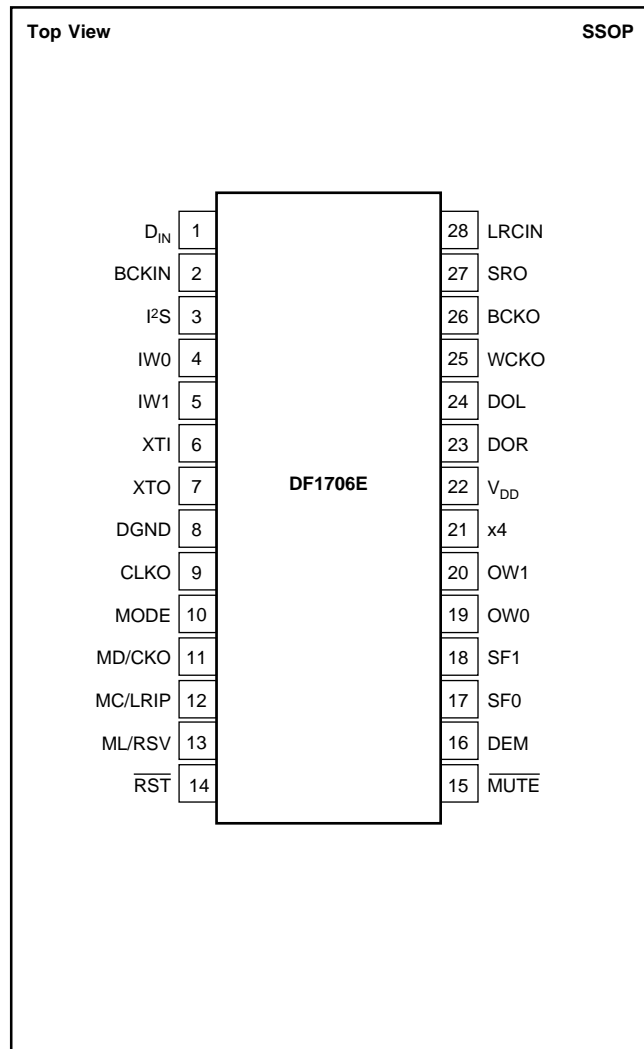

PIN ASSIGNMENTS

PIN	NAME	I/O	DESCRIPTION
1	D _{IN}	IN	Serial Audio Data Input ⁽¹⁾
2	BCKIN	IN	Bit Clock Input for Serial Audio Data ⁽¹⁾
3	I ² S	IN	Input Audio Data Format Select ^(2, 4)
4	IW0	IN	Input Audio Data Word Select ^(2, 4)
5	IW1	IN	Input Audio Data Word Select ^(2, 4)
6	XTI	IN	Oscillator Input/External Clock Input
7	XTO	OUT	Oscillator Output
8	DGND	—	Digital Ground
9	CLKO	OUT	Buffered System Clock Output
10	MODE	IN	Mode Control Select (HIGH: Software Mode, LOW: Hardware Mode) ⁽³⁾
11	MD/CKO	IN	Mode Control, Data/Half External Clock Frequency Select ^(3, 5)
12	MC/LRIP	IN	Mode Control, Clock/Polarity of LRCIN Select ^(3, 5)
13	ML/RSV	IN	Mode Control, Latch Clock/Reserve ^(3, 5)
14	RST	IN	Reset, Active LOW. When this pin is LOW the DF and modulators are held in reset. ⁽³⁾
15	MUTE	IN	Mute Control, Active LOW ⁽⁴⁾
16	DEM	IN	De-Emphasis Control ^(2, 4)
17	SF0	IN	Sampling Rate Select for De-emphasis ^(2, 4)
18	SF1	IN	Sampling Rate Select for De-emphasis ^(2, 4)
19	OW0	IN	Output Audio Data Word Select ^(2, 4)
20	OW1	IN	Output Audio Data Word Select ^(2, 4)
21	x4	IN	Oversampling Ratio Control. When this pin is set HIGH, the ratio is 4 times.
22	V _{DD}	—	Digital Power, +3.3V
23	DOR	OUT	R-Channel, Serial Audio Data Output
24	DOL	OUT	L-Channel, Serial Audio Data Output
25	WCKO	OUT	Word Clock Output for Serial Audio Data Output
26	BCKO	OUT	Bit Clock Output for Serial Audio Data Output
27	SRO	IN	Filter Response Select ^(2, 4)
28	LRCIN	IN	L/R Clock Input (f _s) ⁽¹⁾

NOTES: (1) Pins 1, 2, 28—Schmitt-Trigger input without pull-up and -down resistor. (2) Pins 3-5, 16-21, 27—Schmitt-Trigger input without pull-up and -down resistor. (3) Pins 10-15—Schmitt-Trigger input without pull-up and -down resistor. (4) Pins 3-5, 15-20, 27—these pins are invalid when MODE (pin 10) is HIGH. (5) Pins 11-13—these pins have different functions corresponding to MODE (pin 10) HIGH/LOW.

ABSOLUTE MAXIMUM RATINGS

Supply Voltage	+4.0V
Digital Input Voltage	-0.2V to 4.5V
Input Current (any pins except supplies)	±10mA
Operating Temperature Range	-25°C to +85°C
Ambient Storage Temperature	-40°C to +125°C
Junction Temperature	+150°C
Lead Temperature (soldering, 5s)	+260°C
Package Temperature (IR reflow, Peak, 10s)	+235°C



ELECTROSTATIC DISCHARGE SENSITIVITY

This integrated circuit can be damaged by ESD. Burr-Brown recommends that all integrated circuits be handled with appropriate precautions. Failure to observe proper handling and installation procedures can cause damage.

ESD damage can range from subtle performance degradation to complete device failure. Precision integrated circuits may be more susceptible to damage because very small parametric changes could cause the device not to meet its published specifications.

PACKAGE/ORDERING INFORMATION

PRODUCT	PACKAGE	PACKAGE DRAWING NUMBER	SPECIFIED TEMPERATURE RANGE	PACKAGE MARKING	ORDERING NUMBER ⁽¹⁾	TRANSPORT MEDIA
DF1706E	SSOP-28	324	-25°C to +85°C	DF1706E	DF1706E	Rails
"	"	"	"	"	DF1706E/2K	Tape and Reel

NOTE: (1) Models with a slash (/) are available only in Tape and Reel in the quantities indicated (e.g., /2K indicates 2000 devices per reel). Ordering 2000 pieces of "DF1706E/2K" will get a single 2000-piece Tape and Reel.

TYPICAL PERFORMANCE CURVES

At $T_A = +25^\circ\text{C}$, $V_{DD} = \pm 3.3\text{V}$, $f_S = 44.1\text{kHz}$, System Clock = $256f_S/384f_S$, 16-bit data, unless otherwise noted.

DIGITAL FILTER (DE-EMPHASIS OFF, $f_S = 44.1\text{kHz}$)

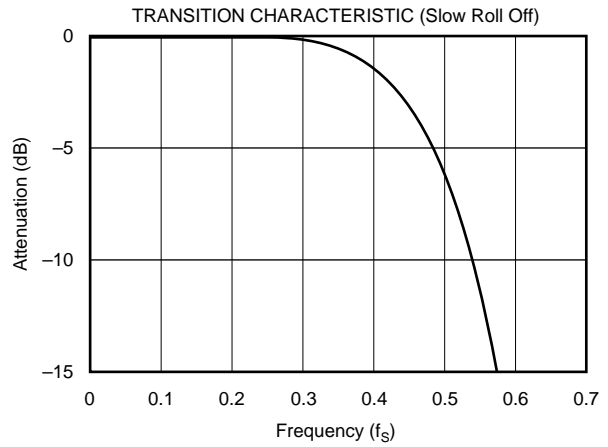
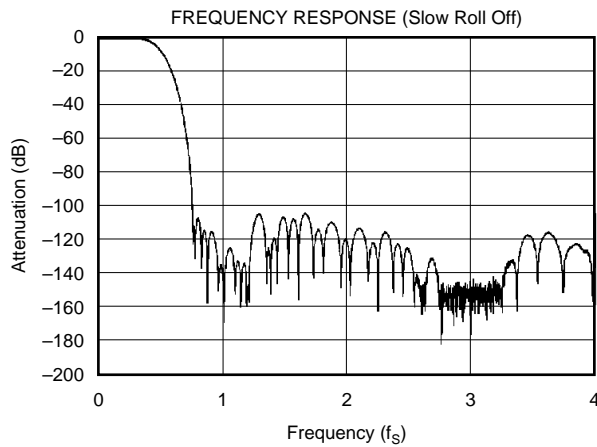
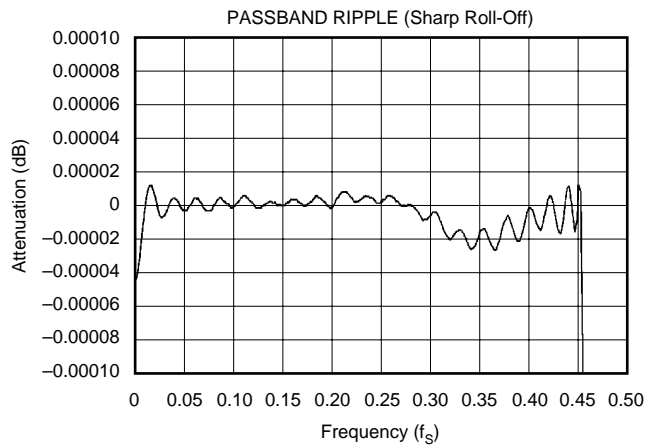
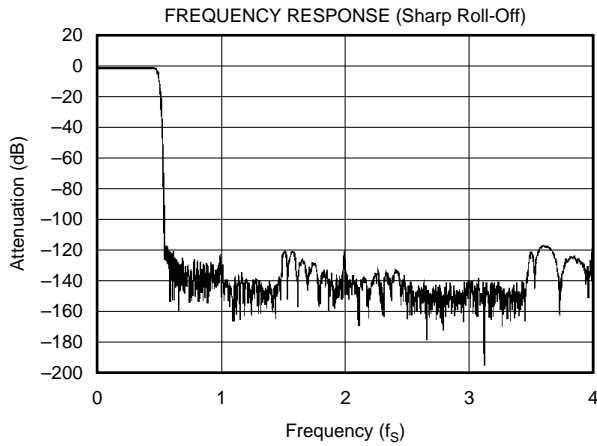

DE-EMPHASIS AND DE-EMPHASIS ERROR

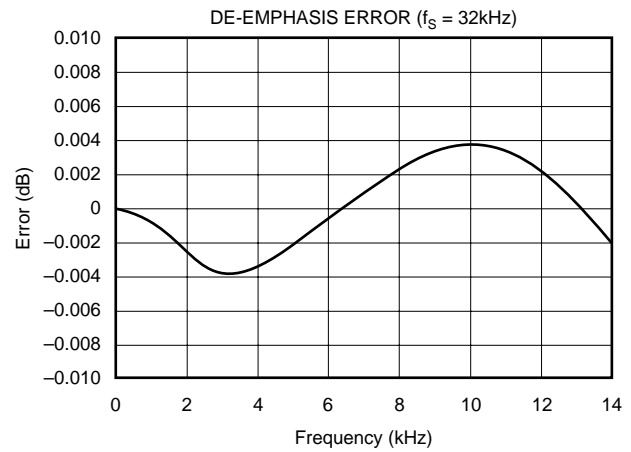
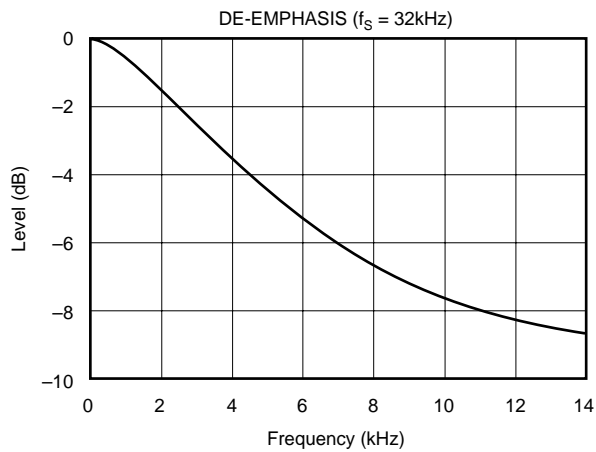

TYPICAL PERFORMANCE CURVES (Cont.)

At $T_A = +25^\circ\text{C}$, $V_{DD} = \pm 3.3\text{V}$, $f_S = 44.1\text{kHz}$, System Clock = $256f_S/384f_S$, 16-bit data, unless otherwise noted.

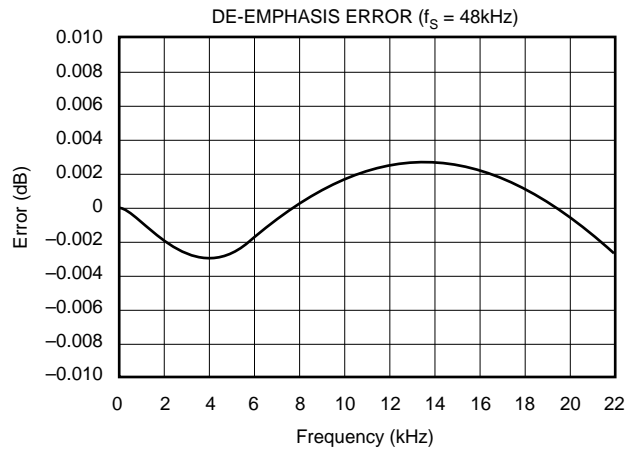
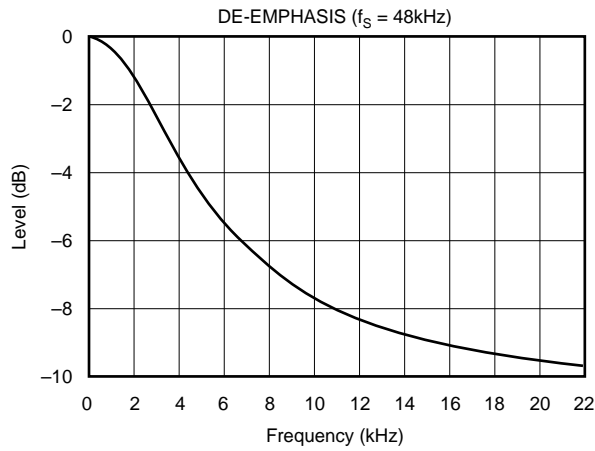
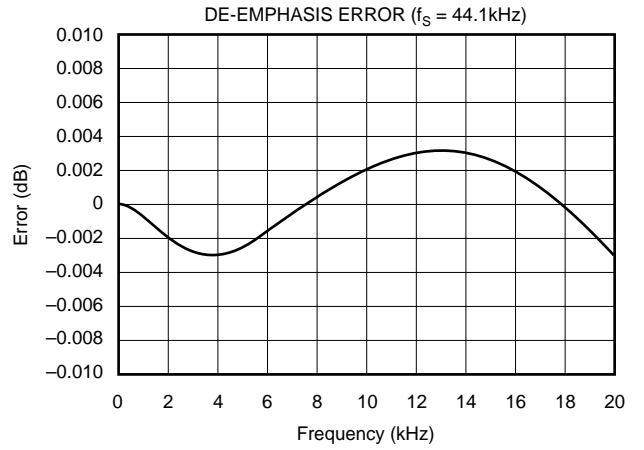
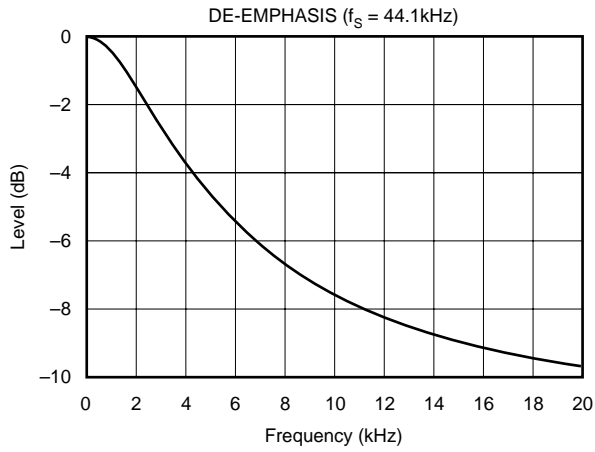

SYSTEM CLOCK REQUIREMENTS

The system clock of the DF1706 can be supplied by either an external clock signal at XTI (pin 6), or by the on-chip crystal oscillator. The system clock rate must run at $128f_s$, $192f_s$, $256f_s$, $384f_s$, $512f_s$, or $768f_s$, where f_s is the audio sampling rate. When a $128f_s$ or $192f_s$ system clock is applied to DF1706, the Over-Sampling Ratio (OSR) of the DF1706's digital filter should be four times instead of eight times. The OSR can be selected by the x4 pin (pin 21) in hardware mode or x4 bit on MODE 2 register in software mode.

It should be noted that a $768f_s$ system clock cannot be used when f_s is larger than 48kHz. Both $128f_s$ and $192f_s$ system clock can be used when f_s is larger than 96kHz. In addition, the on-chip crystal oscillator is limited to a maximum frequency of 24.0MHz. Table I shows the typical system clock frequencies for selected sample rates.

The DF1706 includes a system clock detection circuit that determines the system clock rate in use. The circuit compares the system clock input (XTI) frequency with the LRCIN input rate to determine the system clock multiplier. Ideally, LRCIN and BCKIN should be derived from the system clock to ensure proper synchronization. If the phase difference between the system clock and LRCIN is larger than ± 4 bit clock (BCKIN) periods, the synchronization of the system and LRCIN clocks will be performed automatically by the DF1706.

Timing requirements for the system clock input are shown in Figure 1.

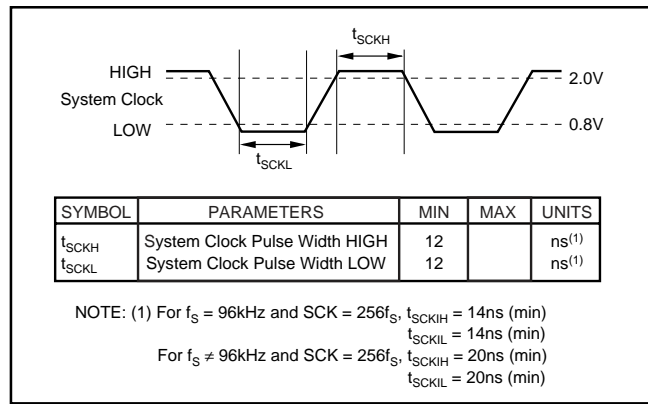

FIGURE 1. System Clock Timing.

RESET

The DF1706 has both an internal power-on reset circuit and a reset pin, \overline{RST} (pin 14), for providing an external reset signal. The internal power-on reset is performed automatically when power is applied to the DF1706, as shown in Figure 2. The \overline{RST} pin can be used to synchronize the DF1706 with a system reset signal, as shown in Figure 3.

During the power-on reset period (1024 system clocks), the outputs of BCKO, DOL, and DOR are forced LOW and the output of WCKO is forced HIGH. For an external forced reset, the outputs of BCKO, DOL, and DOR are forced LOW and the output of WCKO is forced HIGH during the initialization period (1024 system clocks), which occurs after the LOW-to-HIGH transition of the \overline{RST} pin (see Figure 3).

SAMPLING RATE FREQUENCY (f_s)/256 f_s	SYSTEM CLOCK FREQUENCY (MHz)					
	128 f_s	192 f_s	256 f_s	384 f_s	512 f_s	768 f_s
32kHz	N/A	N/A	8.192	12.288	16.384	24.576 ⁽¹⁾
44.1kHz	N/A	N/A	11.2896	16.934	22.5792	33.8688 ⁽¹⁾
48kHz	N/A	N/A	12.288	18.432	24.576 ⁽¹⁾	36.864 ⁽¹⁾
88.2kHz	N/A	N/A	22.5792 ⁽¹⁾	33.8688 ⁽¹⁾	N/A	N/A
96kHz	N/A	N/A	24.576	36.864 ⁽¹⁾	N/A	N/A
176.4kHz	22.5792 ⁽²⁾	33.8688 ⁽¹⁾⁽²⁾	N/A	N/A	N/A	N/A
192kHz	24.576 ⁽¹⁾⁽²⁾	36.864 ⁽¹⁾⁽²⁾	N/A	N/A	N/A	N/A

NOTES: (1) Crystal oscillator frequency using internal oscillator is not covered at frequency larger than 24.0MHz. (2) x4 (pin 21) should be set to HIGH.

TABLE I. Typical System Clock Frequencies.

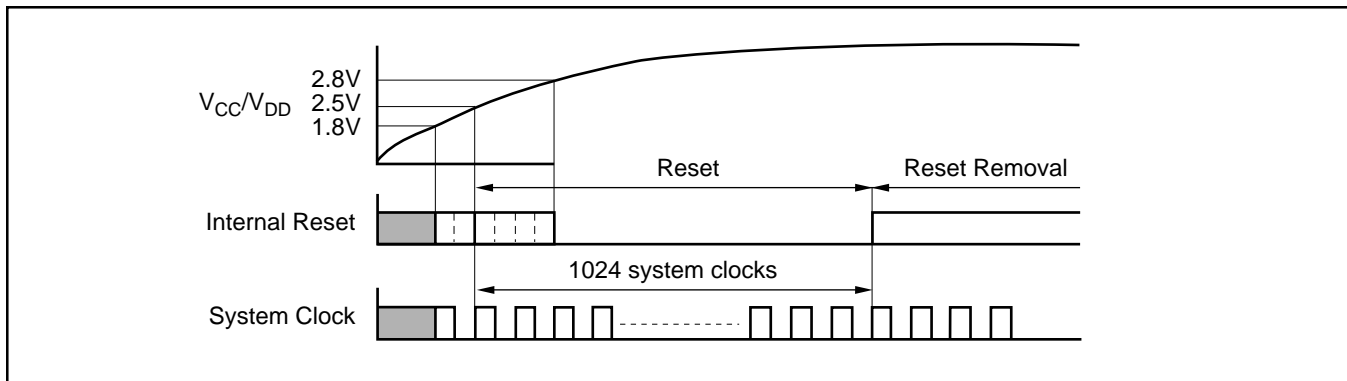

FIGURE 2. Internal Power-On Reset Timing.

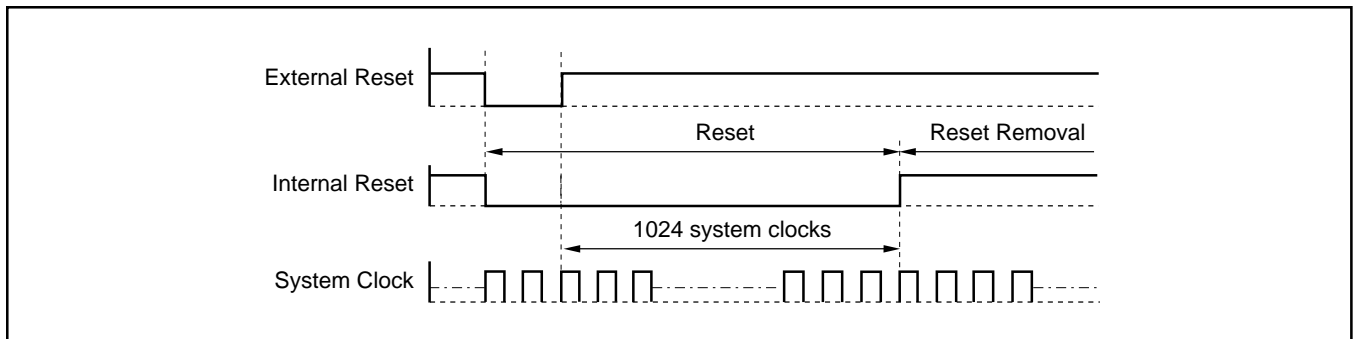

FIGURE 3. External Forces Reset Timing.

AUDIO INPUT INTERFACE

The audio input interface is comprised of BCKIN (pin 2), LRCIN (pin 28), and DIN (pin 1). BCKIN is the input bit clock, which is used to clock data applied at D_{IN} into the DF1706's input serial interface. Input data at D_{IN} is clocked into the DF1706 on the rising edge of BCKIN. The left/right

clock, LRCIN, is used as a word latch for the audio input data. BCKIN can run at $32f_s$, $48f_s$, or $64f_s$, where f_s is the audio sample frequency. LRCIN is run at the f_s rate. Figures 4 (a) through (c) show the input data formats, which are selected by hardware or software controls.

See Figure 5 for the audio input interface timing requirements.

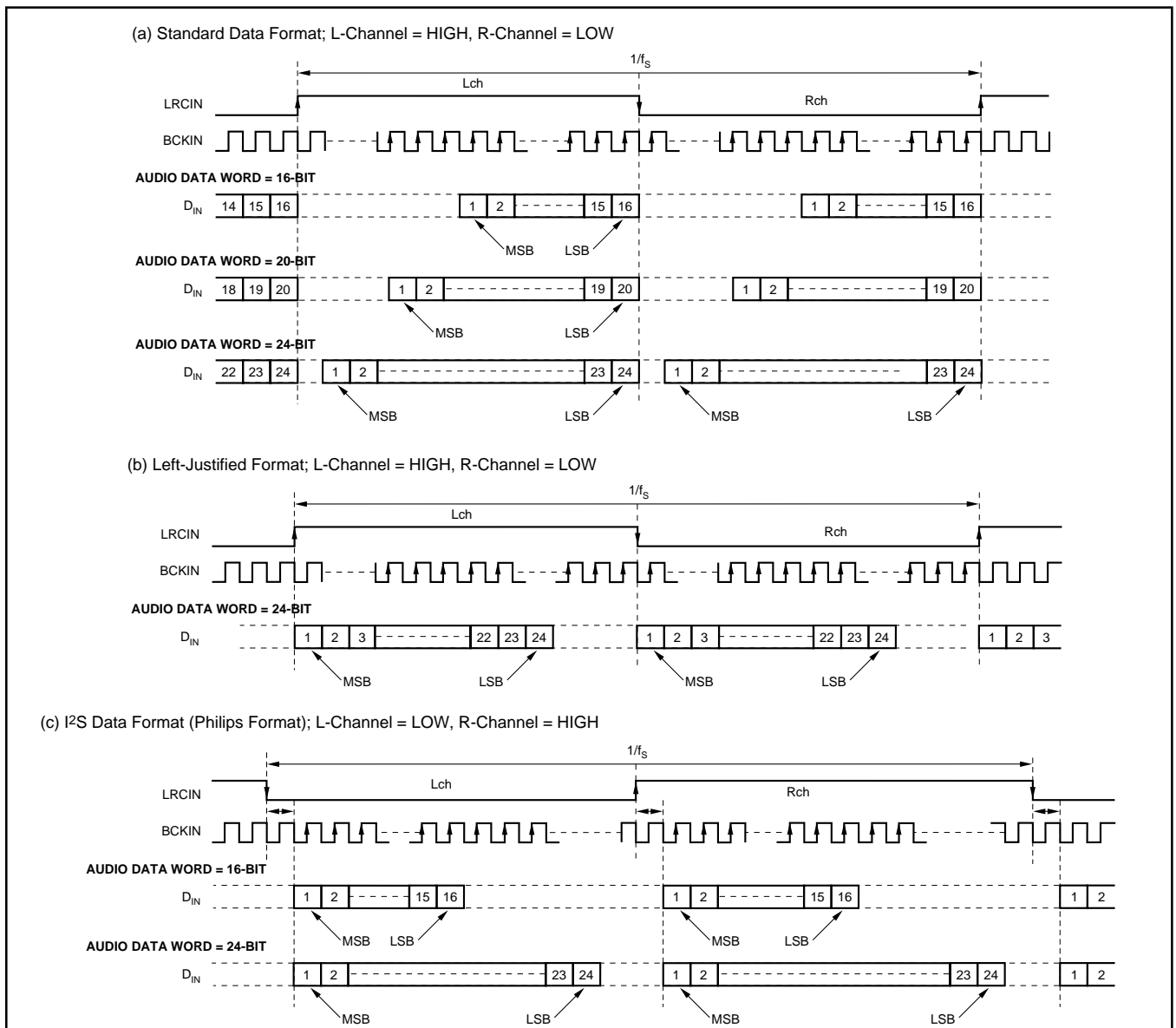

FIGURE 4. Audio Data Input Formats.

AUDIO OUTPUT INTERFACE

The audio output interface includes BCKO (pin 26), WCKO (pin 25), DOL (pin 24), and DOR (pin 23).

BCKO is the output bit clock and is used to clock data into an audio D/A converter, such as the PCM1704. DOL and DOR are the left and right audio data outputs. WCKO is the output word clock and is used to latch audio data words into an audio D/A converter.

WCKO runs at a fixed rate of $8f_s$ (8x oversampling) for all system clock rates.

BCKO is fixed at $256f_s$ for system clock rates of $256f_s$ or $512f_s$.

BCKO is fixed at $192f_s$ for system clock rates of $384f_s$ or $768f_s$.

The output data format used by the DF1706 for DOL and DOR is Binary Two's Complement, MSB-first, right-justified audio data. Figures 6(a), (b), (c), and (d) show the output data formats for the DF1706. See Figure 7 the audio output timing.

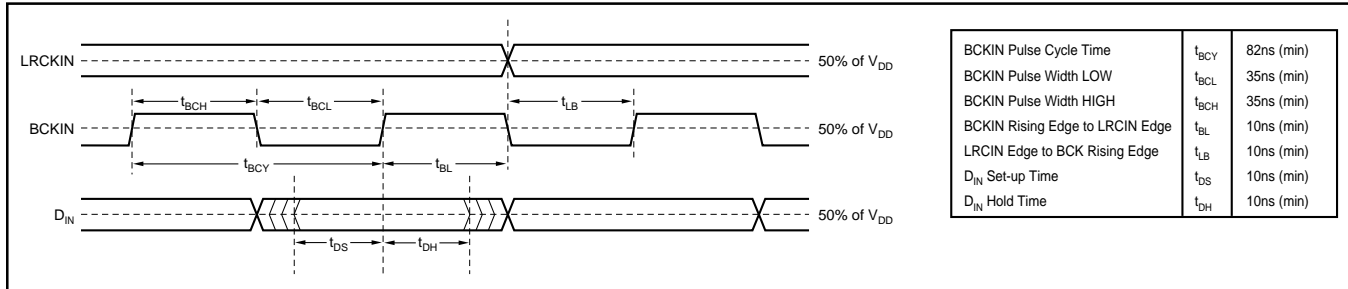

FIGURE 5. Audio Input Interface Timing.

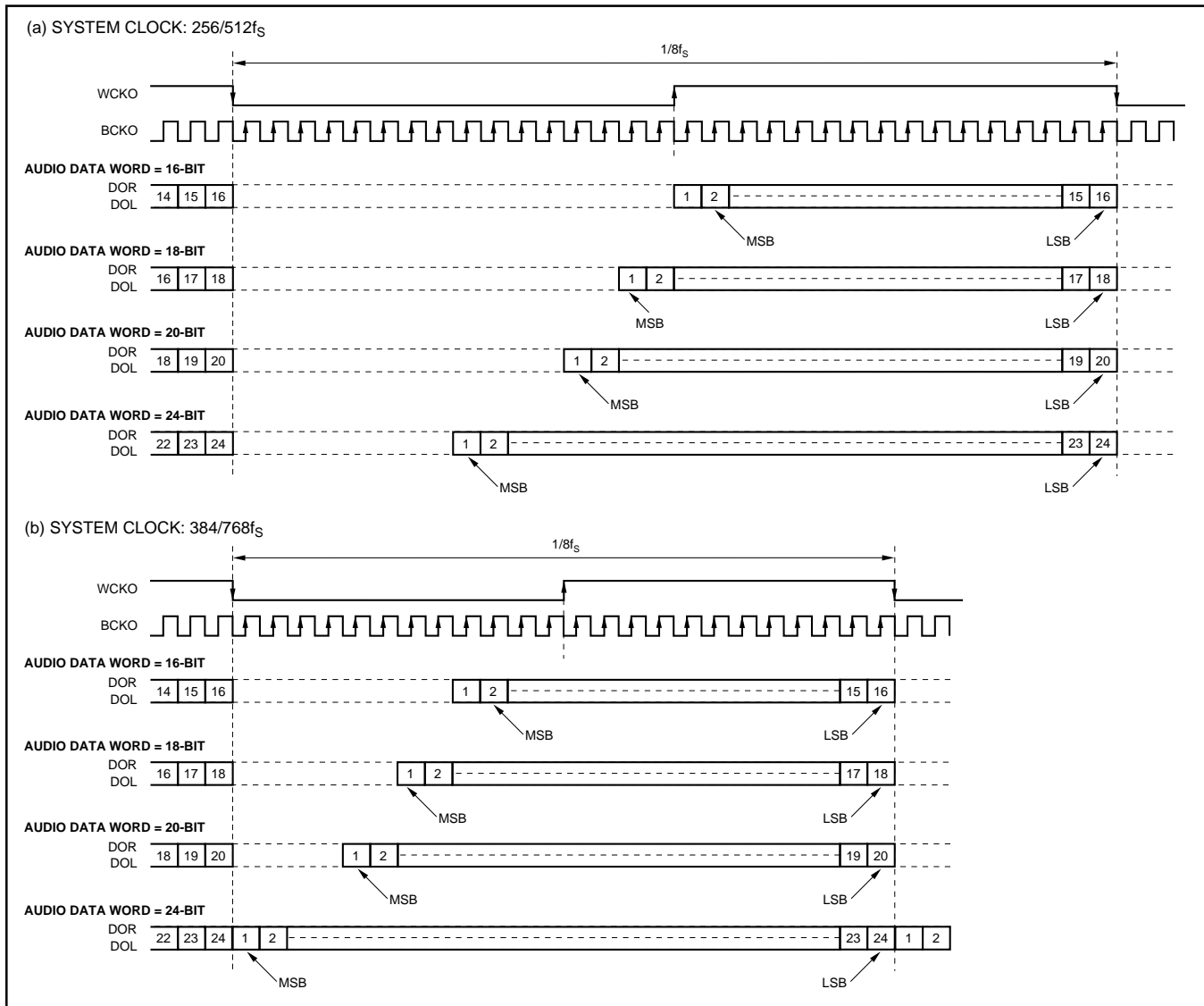
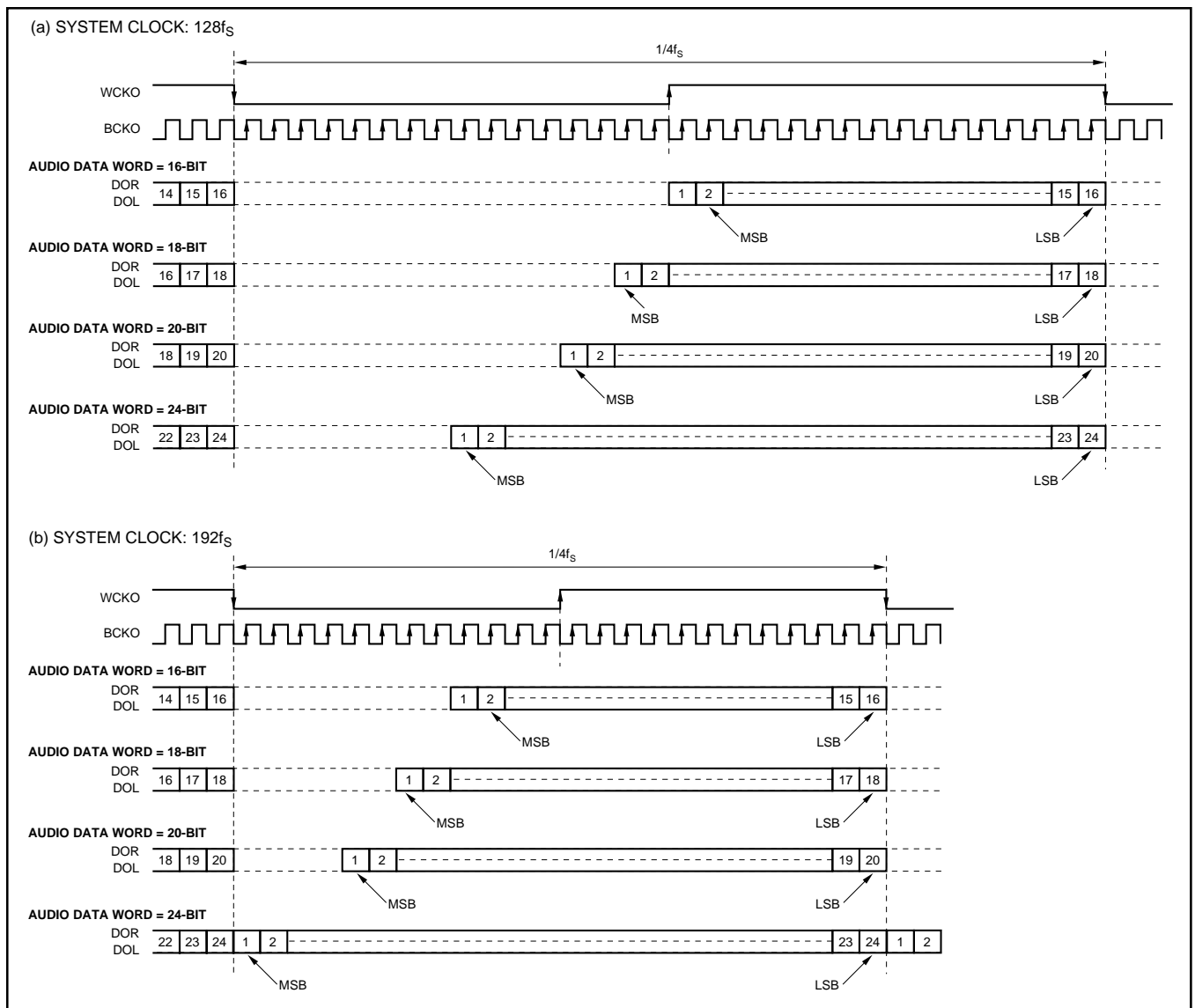

FIGURE 6. Audio Output Data Format.



(Cont.) FIGURE 6. Audio Output Data Format.

MODE CONTROL

The DF1706 may be configured using either software or hardware control. The selection is made using the MODE input (pin 10). See Table II for MODE selection.

MODE SETTING	MODE CONTROL SELECTION
MODE = H	Software Mode
MODE = L	Hardware Mode

TABLE II. MODE Selection.

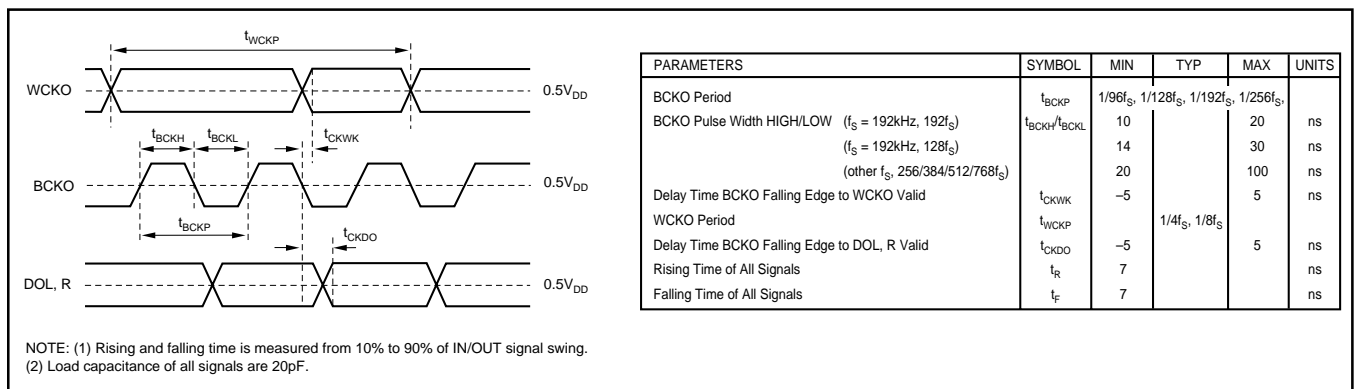

FIGURE 7. Audio Data Output Timing.

Programmable Functions

The DF1706 includes a number of programmable features, with most being accessible from either Hardware or Software mode. Table III summarizes the user-programmable functions for both modes of operation.

FUNCTION	SOFTWARE (MODE = H)	HARDWARE (MODE = L)	RESET DEFAULT (Software Mode)
Input Data Format Selection	O	O	Standard Format
Input Word Length Selection	O	O	16 Bits
Output Word Length Selection	O	O	16 Bits
LRCIN Polarity Selection	O	O	Left/Right = High/Low
Digital De-Emphasis	O	O	OFF
Over Sample Ratio Control	O	O	8x
Soft Mute	O	O	OFF
Digital Attenuation	O	X	0dB, Independent L/R
Sample Rate for De-Emphasis Function	O	O	44.1 kHz
Filter Roll-Off Selection	O	O	Sharp Roll-Off Selected
CLKO Output-Frequency Selection	O	O	Same As XTI Input

Legend: O = User Programmable, X = Not Available.

TABLE III. User-Programmable Functions for Software and Hardware Mode.

Hardware Mode Controls

With MODE = L, the DF1706 may be configured by utilizing several user-programmable pins. The following is a brief summary of the pin functions. Table IV provides more details on setting the hardware mode controls.

Pins I²S, IW0, and IW1 are used to select the audio data input format and word length.

Pins OW0 and OW1 are used to select the output data word length.

The DEM pin is used to enable and disable the digital de-emphasis function. De-emphasis is only available for 32kHz, 44.1kHz, and 48kHz sample rates.

Pins SF0 and SF1 are used to select the sample rate for the de-emphasis function.

The SRO pin is used to select the digital filter response, either sharp or slow roll-off. Generally, sharp roll-off filter is used.

The MUTE pin is used to enable or disable the soft mute function.

The CKO pin is used to select the clock frequency seen at the CLKO pin, either XTI or XTI ÷ 2.

The LRIP pin is used to select the polarity used for the audio input left/right clock, LRCIN.

The x4 pin is used to control the over sampling ratio of the internal digital filter, either a 8x or 4x. For instance, when fs is 192kHz or 176.4kHz, the over sampling ratio should be 4x.

PIN NAME	PIN NUMBER	DESCRIPTION																												
RSV	13	Reserved, Not Used																												
LRIP	12	LRCIN Polarity LRIP = H: LRCIN= H = Left Channel, LRCIN= L = Right Channel LRIP = L: LRCIN= L = Left Channel, LRCIN = H = Right Channel																												
CKO	11	CLKO Output Frequency CKO = H: CLKO Frequency = XTI/2 CKO = L: CLKO Frequency = XTI																												
MUTE	15	Soft Mute Control: H = Mute Off, L = Mute On																												
I ² S IW0 IW1	3 4 5	Input Data Format Controls <table border="1"> <thead> <tr> <th>I²S</th> <th>IW1</th> <th>IW0</th> <th>INPUT FORMAT</th> </tr> </thead> <tbody> <tr> <td>L</td> <td>L</td> <td>L</td> <td>16-Bit, Standard, MSB-First, Right-Justified</td> </tr> <tr> <td>L</td> <td>L</td> <td>H</td> <td>20-Bit, Standard, MSB-First, Right-Justified</td> </tr> <tr> <td>L</td> <td>H</td> <td>L</td> <td>24-Bit, Standard, MSB-First, Right-Justified</td> </tr> <tr> <td>L</td> <td>H</td> <td>H</td> <td>24-Bit, MSB-First, Left-Justified</td> </tr> <tr> <td>H</td> <td>L</td> <td>L</td> <td>16-Bit, I²S</td> </tr> <tr> <td>H</td> <td>L</td> <td>H</td> <td>24-Bit, I²S</td> </tr> </tbody> </table>	I ² S	IW1	IW0	INPUT FORMAT	L	L	L	16-Bit, Standard, MSB-First, Right-Justified	L	L	H	20-Bit, Standard, MSB-First, Right-Justified	L	H	L	24-Bit, Standard, MSB-First, Right-Justified	L	H	H	24-Bit, MSB-First, Left-Justified	H	L	L	16-Bit, I ² S	H	L	H	24-Bit, I ² S
I ² S	IW1	IW0	INPUT FORMAT																											
L	L	L	16-Bit, Standard, MSB-First, Right-Justified																											
L	L	H	20-Bit, Standard, MSB-First, Right-Justified																											
L	H	L	24-Bit, Standard, MSB-First, Right-Justified																											
L	H	H	24-Bit, MSB-First, Left-Justified																											
H	L	L	16-Bit, I ² S																											
H	L	H	24-Bit, I ² S																											
SRO	27	Digital Filter Roll-Off: H = Slow, L = Sharp																												
OW0 OW1	19 20	Output Data Word Length Controls <table border="1"> <thead> <tr> <th>OW1</th> <th>OW0</th> <th>OUTPUT FORMAT</th> </tr> </thead> <tbody> <tr> <td>L</td> <td>L</td> <td>16-Bit, MSB-First</td> </tr> <tr> <td>L</td> <td>H</td> <td>18-Bit, MSB-First</td> </tr> <tr> <td>H</td> <td>L</td> <td>20-Bit, MSB-First</td> </tr> <tr> <td>H</td> <td>H</td> <td>24-Bit, MSB-First</td> </tr> </tbody> </table>	OW1	OW0	OUTPUT FORMAT	L	L	16-Bit, MSB-First	L	H	18-Bit, MSB-First	H	L	20-Bit, MSB-First	H	H	24-Bit, MSB-First													
OW1	OW0	OUTPUT FORMAT																												
L	L	16-Bit, MSB-First																												
L	H	18-Bit, MSB-First																												
H	L	20-Bit, MSB-First																												
H	H	24-Bit, MSB-First																												
SF0 SF1	17 18	Sample Rate Selection for the Digital De-Emphasis Control <table border="1"> <thead> <tr> <th>SF1</th> <th>SF0</th> <th>SAMPLING RATE</th> </tr> </thead> <tbody> <tr> <td>L</td> <td>L</td> <td>44.1kHz</td> </tr> <tr> <td>L</td> <td>H</td> <td>Reserved, Not Used</td> </tr> <tr> <td>H</td> <td>L</td> <td>48kHz</td> </tr> <tr> <td>H</td> <td>H</td> <td>32kHz</td> </tr> </tbody> </table>	SF1	SF0	SAMPLING RATE	L	L	44.1kHz	L	H	Reserved, Not Used	H	L	48kHz	H	H	32kHz													
SF1	SF0	SAMPLING RATE																												
L	L	44.1kHz																												
L	H	Reserved, Not Used																												
H	L	48kHz																												
H	H	32kHz																												
DEM	16	Digital De-Emphasis: H = On, L = Off																												
x4	21	Oversampling Rate Control: H = 4f _s , L = 8f _s																												

TABLE IV. Hardware Mode Controls.

Finally, the RESV pin is not used by the current DF1706 design, but is reserved for future use.

Software Mode Controls

With MODE = H, the DF1706 may be configured by programming four internal registers in software mode. ML (pin 13), MC (pin 12), and MD (pin 11) make up the 3-wire software control port, and may be controlled using DSP or microcontroller general purpose I/O pins, or a serial port. Table V provides an overview of the internal registers, labeled MODE0 through MODE3 (see Table V).

See Figures 8 through 10 for more details regarding the control port data format and timing requirements. The data format for the control port is 16-bit, MSB-first, with Bit B15 being the MSB.

Register Addressing

A[1:0], bits B10 and B9 of the 16-bit control data word, are used to indicate the register address to be written to by the current control port write cycle. See Table VI for how to address the internal registers using bits A[1:0] of registers MODE0 through MODE3.

	B15	B14	B13	B12	B11	B10	B9	B8	B7	B6	B5	B4	B3	B2	B1	B0
MODE0	res	res	res	res	res	A1	A0	LDL	AL7	AL6	AL5	AL4	AL3	AL2	AL1	AL0
MODE1	res	res	res	res	res	A1	A0	LDR	AR7	AR6	AR5	AR4	AR3	AR2	AR1	AR0
MODE2	res	res	res	res	res	A1	A0	res	res	OW1	OW0	IW1	IW0	x4	DEM	MUT
MODE3	res	res	res	res	res	A1	A0	res	SF1	SF0	CKO	res	SRO	ATC	LRP	I ² S

FIGURE 8. Internal Mode Control Registers.

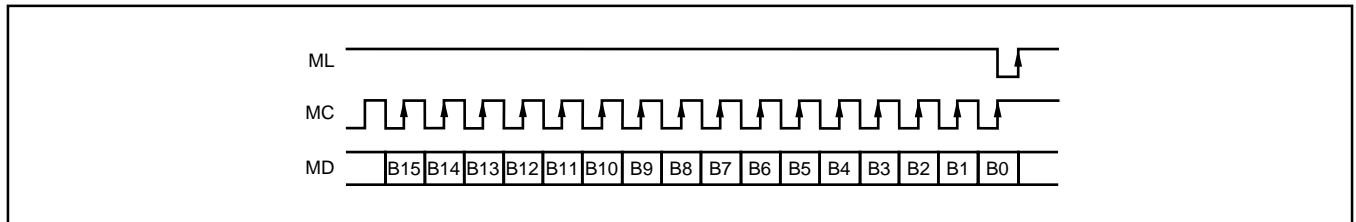

FIGURE 9. Software Interface Format.

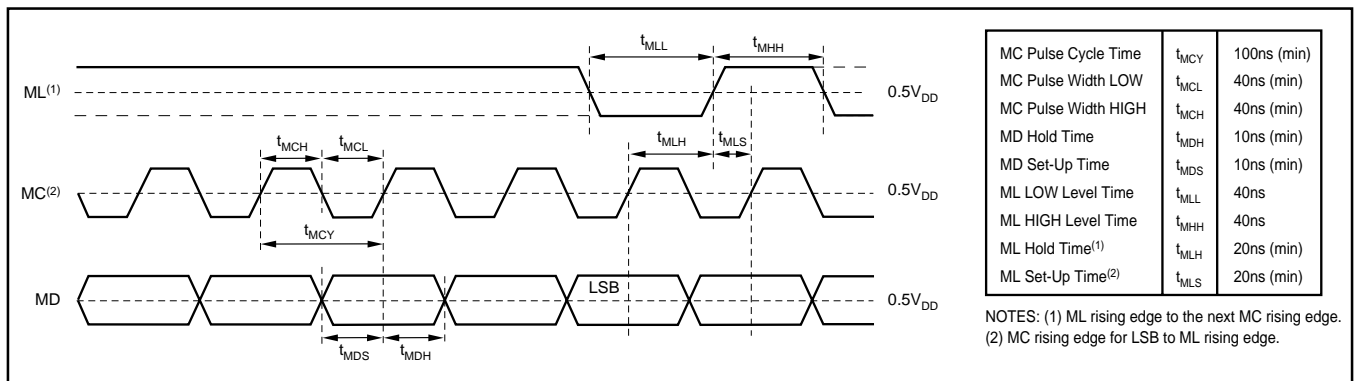

FIGURE 10. Software Interface Timing Requirements.

REGISTER NAME	BIT NAME	DESCRIPTION
MODE0	AL[7:0]	Attenuation Data for the Left Channel
	LDL	Attenuation Load Control for the Left Channel
	A[1:0]	Register Address
	res	Reserved
MODE1	AR[7:0]	Attenuation Data for the Right Channel
	LDR	Attenuation Load Control for the Right Channel
	A[1:0]	Register Address
	res	Reserved
MODE2	MUT	Soft Mute Control
	DEM	Digital De-Emphasis Control
	x4	Oversampling Rate Control
	IW[1:0]	Input Data Format and Word Length
	OW[1:0]	Output Data Word Length
	A[1:0]	Register Address
res	Reserved	
MODE3	I ² S	Input Data Format (I ² S or Standard/Left-Justified)
	LRP	LRCIN Polarity
	ATC	Attenuator Control, Dependent or Independent
	SRO	Digital Filter Roll-Off Selection (sharp or slow)
	CKO	CLKO Frequency Selection (XTI or XTI + 2)
	SF[1:0]	Sample Rate Selection for De-Emphasis Function
	A[1:0]	Register Address
res	Reserved	

NOTE: All reserved bits should be programmed to 0.

TABLE V. Internal Register Mapping.

A1	A0	REGISTER SELECTED
0	0	MODE0
0	1	MODE1
1	0	MODE2
1	1	MODE3

TABLE VI. Internal Register Addressing.

MODE0 Register

The MODE0 register is used to set the attenuation data for the left output channel, or DOL (pin 24).

When ATC = 1 (Bit B2 of Register MODE3 = 1), the left channel attenuation data AL[7:0] is used for both the left and right channel attenuators.

When ATC = 0, (Bit B2 of Register MODE3 = 0), left channel attenuation data is taken from AL[7:0] of register MODE0, and right channel attenuation data is taken from AR[7:0] of register MODE1.

AL[7:0] Left Channel Attenuator Data, where AL7 is the MSB and AL0 is the LSB.

Attenuation Level is given by:

$$\text{ATTEN} = 0.5 \cdot (\text{DATA} - 255)\text{dB}$$

For DATA = FF_H, ATTEN = -0dB

For DATA = FE_H, ATTEN = -0.5dB

For DATA = 01_H, ATTEN = -127.5dB

For DATA = 00_H, ATTEN = infinity = Mute

LDL Left Channel Attenuation Data Load Control. This bit is used to simultaneously set attenuation levels of both the left and right channels.

When LDL = 1, the left channel output level is set by the data in AL[7:0]. The right channel output level is set by the data in AL[7:0], or the most recently programmed data in bits AR[7:0] of register MODE1.

When LDL = 0, the left channel output data remains at its previously programmed level.

MODE1 Register

The MODE1 register is used to set the attenuation data for the right output channel, or DOR (pin 23).

When ATC = 1 (Bit B2 of Register MODE3 = 1), the left channel attenuation data AL[7:0] of register MODE0 is used for both the left and right channel attenuators.

When ATC = 0, (Bit B2 of Register MODE3 = 0), left channel attenuation data is taken from AL[7:0] of register MODE0, and right channel attenuation data is taken from AR[7:0] of register MODE1.

AR[7:0] Right Channel Attenuator Data, where AR7 is the MSB and AR0 is the LSB. Attenuation Level is given by:

$$\text{ATTEN} = 0.5 \cdot (\text{DATA} - 255)\text{dB}$$

For DATA = FF_H, ATTEN = -0dB

For DATA = FE_H, ATTEN = -0.5dB

For DATA = 01_H, ATTEN = -127.5dB

For DATA = 00_H, ATTEN = infinity = Mute

LDR Right Channel Attenuation Data Load Control. This bit is used to simultaneously set attenuation levels of both the left and right channels.

When LDR = 1, the right channel output level is set by the data in AR[7:0], or by the data in bits AL[7:0] of register MODE0. The left channel output level is set to the most recently

programmed data in bits AL[7:0] of register MODE0.

When LDR = 0, the right channel output data remains at its previously programmed level.

MODE2 Register

The MODE2 register is used to program various functions:

MUT Soft Mute Function.

When MUT = 0, Soft Mute is ON for both left and right channels.

When MUT = 1, Soft Mute is OFF for both left and right channels.

DEM Digital De-Emphasis Function.

When DEM = 0, de-emphasis is OFF.

When DEM = 1, de-emphasis is ON.

x4 Oversampling Rate Selection

When x4 = 0, 8f_s Sampling Rate Operation

When x4 = 1, 4f_s Sampling Rate Operation

IW[1:0] Input Data Format and Word Length.

I ² S	IW1	IW0	Description
0	0	0	16-Bit Data, Standard Format (MSB-First, Right-Justified)
0	0	1	20-Bit Data, Standard Format
0	1	0	24-Bit Data, Standard Format
0	1	1	24-Bit Data, MSB-First, Left-Justified
1	0	0	16-Bit Data, I ² S Format
1	0	1	24-Bit Data, I ² S format
1	1	0	Reserved
1	1	1	Reserved

OW[1:0] Output Data Word Length.

OW1	OW0	Description
0	0	16-Bit Data, MSB-First
0	1	18-Bit Data, MSB-First
1	0	20-Bit Data, MSB-First
1	1	24-Bit Data, MSB-First

MODE3 Register

The MODE3 register is used to program various functions.

I²S Input Data Format.

When I²S = 0, standard or left-justified formats are enabled.

When I²S = 1, the I²S formats are enabled.

LRP LRCIN Polarity Selection.

When LRP = 0, left channel is HIGH and right channel is LOW.

When LRP = 1, left channel is LOW and right channel is HIGH.

- ATC** Attenuator Control.
This bit is used to determine whether the Left and Right channel attenuators operate with independent data, or use common data (the Left channel data in bits AL[7:0] of register MODE0).
When ATC = 0, the Left and Right channel attenuator data is independent.
When ATC = 1, the Left and Right channel attenuators use common data.
- SRO** Digital Filter Roll-Off Selection.
When SRO = 0, sharp roll-off is selected.
When SRO = 1, slow roll-off is selected.
- CKO** CLKO Output Frequency Selection.
When CKO = 0, the CLKO frequency is the same as the clock at the XTI input.
When CKO = 1, the CLKO frequency is half of the XTI input clock frequency.

SF[1:0] Sampling Frequency Selection for the De-Emphasis Function.

SF1	SF0	Description
0	0	44.1 kHz
0	1	Reserved
1	0	48 kHz
1	1	32 kHz

APPLICATIONS INFORMATION

PCB LAYOUT GUIDELINES

In order to obtain the specified performance from the DF1706 and its associated D/A converters, proper printed circuit board layout is essential. Figure 11 shows two approaches for obtaining the best audio performance.

Figure 11(a) shows a standard, mixed signal layout scheme. The board is divided into digital and analog sections, each with its own ground. The ground areas should be put on a split-plane, separate from the routing and power layers. The DF1706 and all digital circuitry should be placed over the digital section, while the audio D/A converter(s) and analog circuitry should be located over the analog section of the board. A common connection between the digital and analog grounds is required and is done at a single point as shown.

For Figure 11(a), digital signals should be routed from the DF1706 to the audio D/A converter(s) using short, direct connections to reduce the amount of radiated high-frequency energy. If necessary, series resistors may be placed in the clock and data signal paths to reduce or eliminate any overshoot or undershoot present on these signals. A value of 50Ω to 100Ω is recommended as a starting point, but the designer should experiment with the resistor values in order to obtain the best results.

Figure 11(b) shows an improved method for high-performance, mixed signal board layout. This method adds digital isolation between the DF1706 and the audio D/A converter(s), and provides complete isolation between the digital and analog sections of the board. The ISO150 dual digital coupler provides excellent isolation, and operates at speeds up to 80Mbps.

POWER SUPPLIES AND BYPASSING

The DF1706 requires a single +5V power supply for operation. The power supply should be bypassed by a 10μF and 0.1μF parallel capacitor combination. The capacitors should be placed as close as possible to V_{DD} (pin 22). Aluminum electrolytics or tantalum capacitors can be used for the 10μF value, while ceramics may be used for the 0.1μF value.

BASIC CIRCUIT CONNECTIONS

See Figures 12 and 13 for basic circuit connections of the DF1706. Figure 12 shows connections for Hardware mode controls, while Figure 13 shows connections for Software mode controls. Notice the placement of C₁ and C₂ in both figures, as they are physically close to the DF1706.

TYPICAL APPLICATIONS

The DF1706 will typically be used in high performance audio equipment, in conjunction with high performance audio D/A converters. Figure 14 shows a typical application circuit example, employing the DF1706, a digital audio receiver, and two PCM1704 24-bit, 192kHz audio D/A converter(s).

(a) Layout Without Isolation

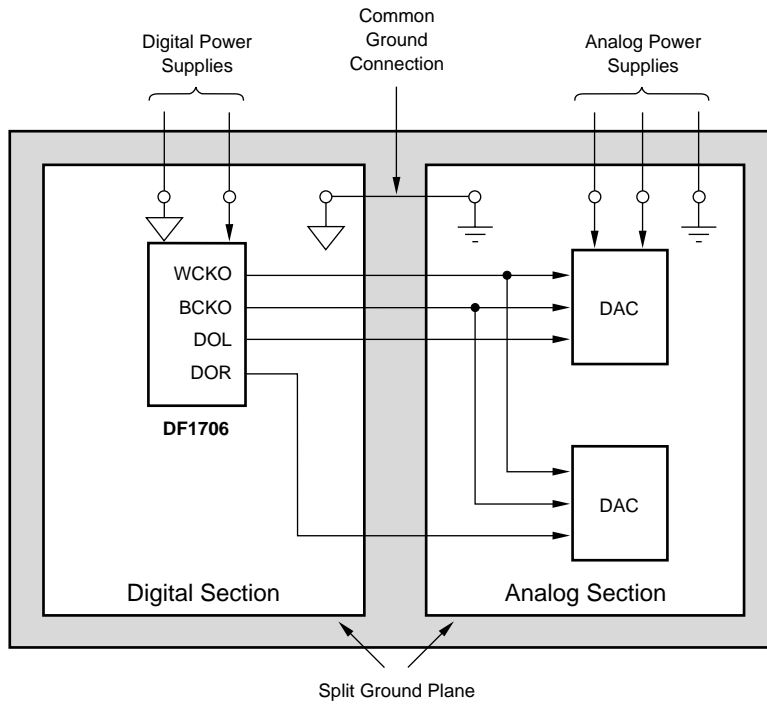

(b) Layout With Isolation

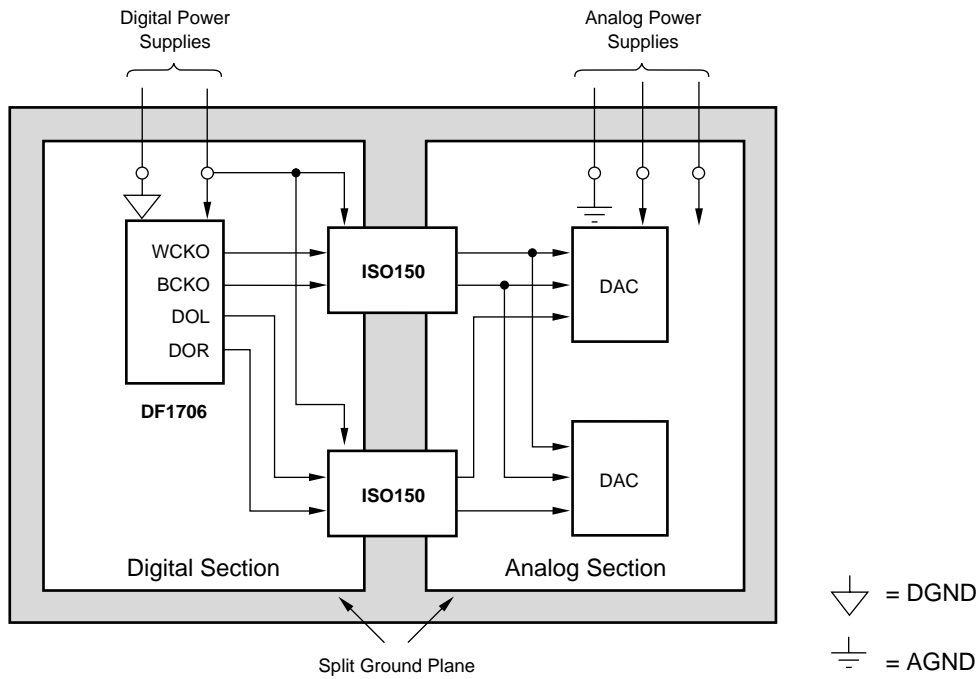

FIGURE 11. PCB Layout Model.

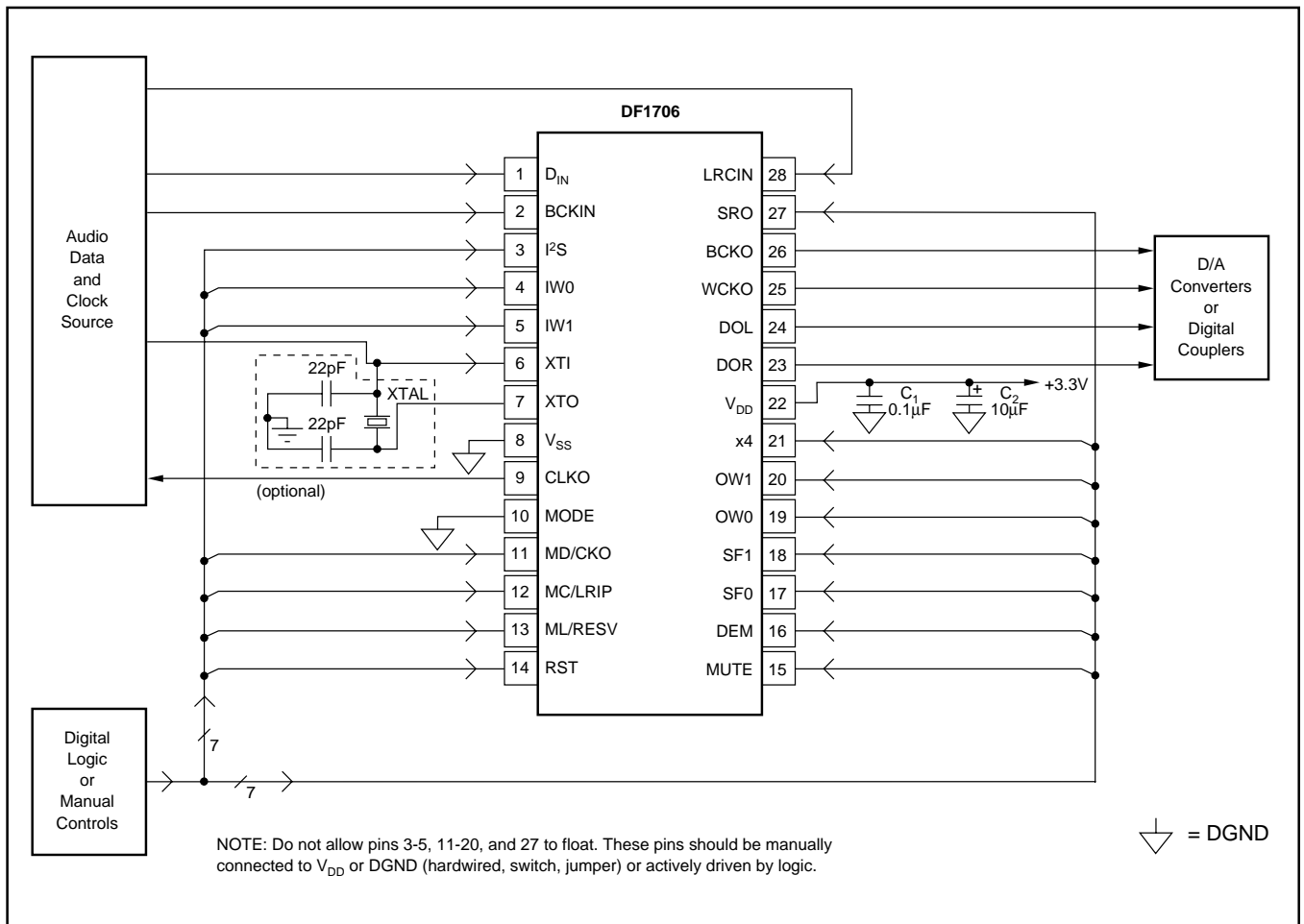

FIGURE 12. Basic Circuit Connections, Hardware Control.

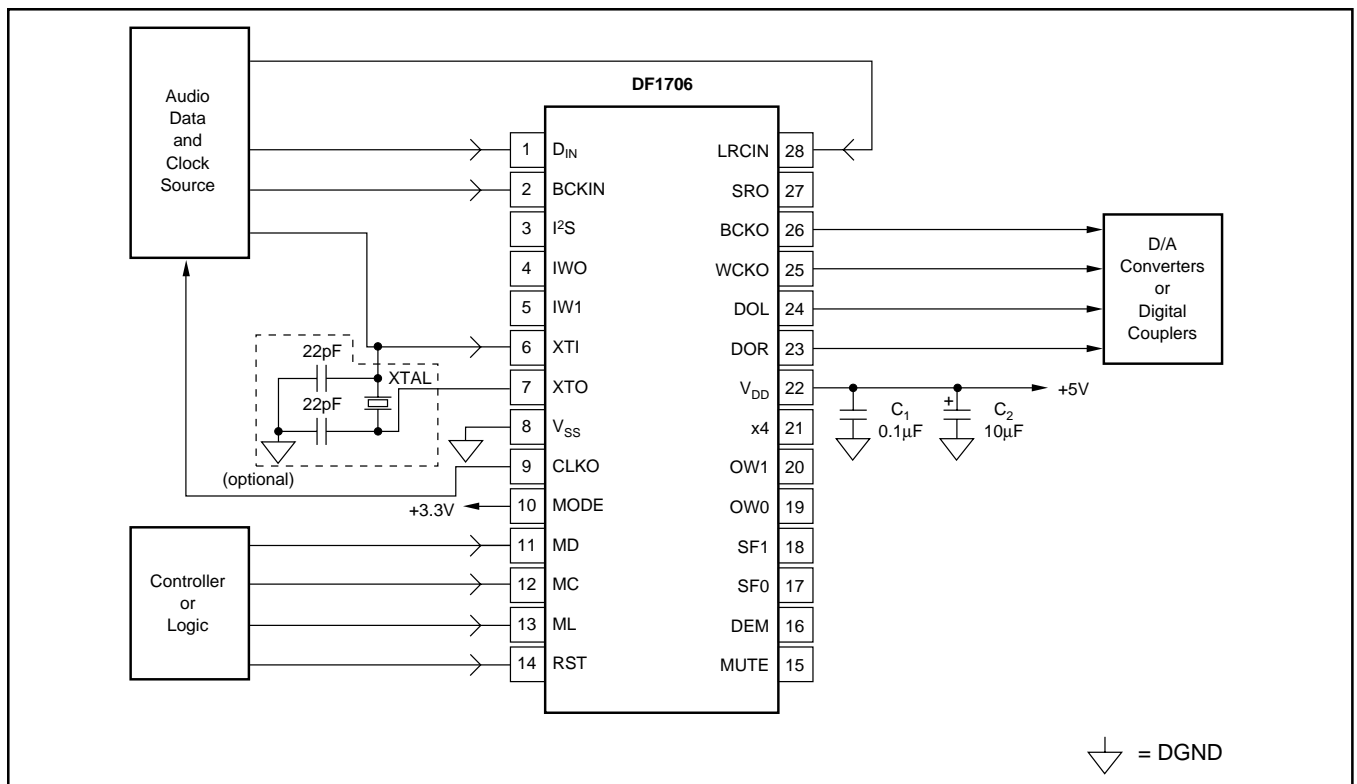

FIGURE 13. Basic Circuit Connection, Software Control.

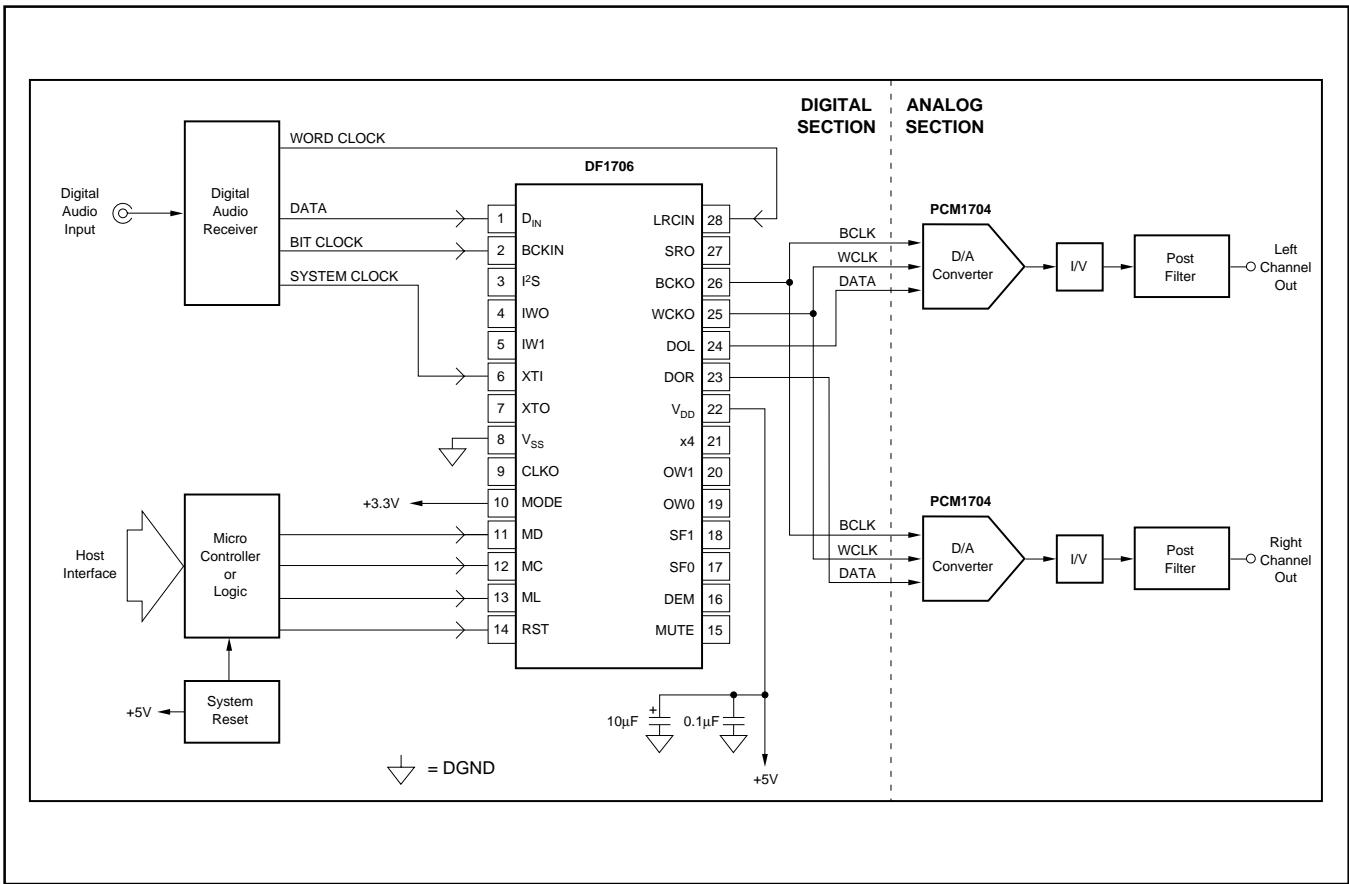

FIGURE 14. DF1706 Typical Application Circuit.

PACKAGING INFORMATION

Orderable Device	Status ⁽¹⁾	Package Type	Package Drawing	Pins	Package Qty	Eco Plan ⁽²⁾	Lead/Ball Finish	MSL Peak Temp ⁽³⁾
DF1706E	NRND	SSOP	DB	28	47	Green (RoHS & no Sb/Br)	CU NIPDAU	Level-1-260C-UNLIM
DF1706E/2K	NRND	SSOP	DB	28	2000	Green (RoHS & no Sb/Br)	CU NIPDAU	Level-1-260C-UNLIM
DF1706E/2KG4	NRND	SSOP	DB	28	2000	Green (RoHS & no Sb/Br)	CU NIPDAU	Level-1-260C-UNLIM
DF1706EG4	NRND	SSOP	DB	28	47	Green (RoHS & no Sb/Br)	CU NIPDAU	Level-1-260C-UNLIM

⁽¹⁾ The marketing status values are defined as follows:

ACTIVE: Product device recommended for new designs.

LIFEBUY: TI has announced that the device will be discontinued, and a lifetime-buy period is in effect.

NRND: Not recommended for new designs. Device is in production to support existing customers, but TI does not recommend using this part in a new design.

PREVIEW: Device has been announced but is not in production. Samples may or may not be available.

OBSOLETE: TI has discontinued the production of the device.

⁽²⁾ Eco Plan - The planned eco-friendly classification: Pb-Free (RoHS), Pb-Free (RoHS Exempt), or Green (RoHS & no Sb/Br) - please check <http://www.ti.com/productcontent> for the latest availability information and additional product content details.

TBD: The Pb-Free/Green conversion plan has not been defined.

Pb-Free (RoHS): TI's terms "Lead-Free" or "Pb-Free" mean semiconductor products that are compatible with the current RoHS requirements for all 6 substances, including the requirement that lead not exceed 0.1% by weight in homogeneous materials. Where designed to be soldered at high temperatures, TI Pb-Free products are suitable for use in specified lead-free processes.

Pb-Free (RoHS Exempt): This component has a RoHS exemption for either 1) lead-based flip-chip solder bumps used between the die and package, or 2) lead-based die adhesive used between the die and leadframe. The component is otherwise considered Pb-Free (RoHS compatible) as defined above.

Green (RoHS & no Sb/Br): TI defines "Green" to mean Pb-Free (RoHS compatible), and free of Bromine (Br) and Antimony (Sb) based flame retardants (Br or Sb do not exceed 0.1% by weight in homogeneous material)

⁽³⁾ MSL, Peak Temp. -- The Moisture Sensitivity Level rating according to the JEDEC industry standard classifications, and peak solder temperature.

Important Information and Disclaimer:The information provided on this page represents TI's knowledge and belief as of the date that it is provided. TI bases its knowledge and belief on information provided by third parties, and makes no representation or warranty as to the accuracy of such information. Efforts are underway to better integrate information from third parties. TI has taken and continues to take reasonable steps to provide representative and accurate information but may not have conducted destructive testing or chemical analysis on incoming materials and chemicals. TI and TI suppliers consider certain information to be proprietary, and thus CAS numbers and other limited information may not be available for release.

In no event shall TI's liability arising out of such information exceed the total purchase price of the TI part(s) at issue in this document sold by TI to Customer on an annual basis.

TAPE AND REEL INFORMATION

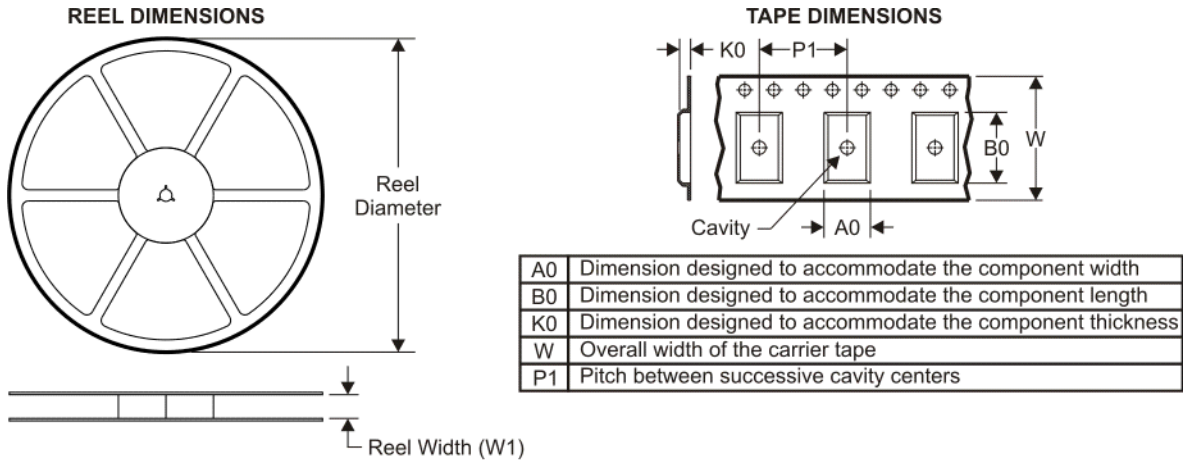

QUADRANT ASSIGNMENTS FOR PIN 1 ORIENTATION IN TAPE

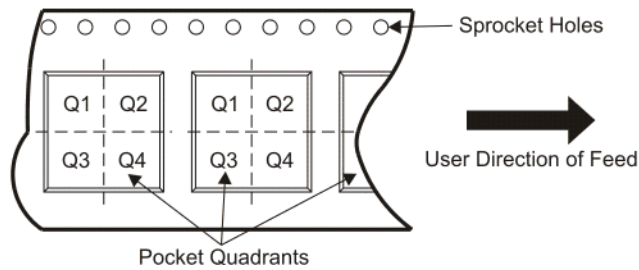

*All dimensions are nominal

Device	Package Type	Package Drawing	Pins	SPQ	Reel Diameter (mm)	Reel Width W1 (mm)	A0 (mm)	B0 (mm)	K0 (mm)	P1 (mm)	W (mm)	Pin1 Quadrant
DF1706E/2K	SSOP	DB	28	2000	330.0	17.4	8.5	10.8	2.4	12.0	16.0	Q1

TAPE AND REEL BOX DIMENSIONS



*All dimensions are nominal

Device	Package Type	Package Drawing	Pins	SPQ	Length (mm)	Width (mm)	Height (mm)
DF1706E/2K	SSOP	DB	28	2000	336.6	336.6	28.6

IMPORTANT NOTICE

Texas Instruments Incorporated and its subsidiaries (TI) reserve the right to make corrections, modifications, enhancements, improvements, and other changes to its products and services at any time and to discontinue any product or service without notice. Customers should obtain the latest relevant information before placing orders and should verify that such information is current and complete. All products are sold subject to TI's terms and conditions of sale supplied at the time of order acknowledgment.

TI warrants performance of its hardware products to the specifications applicable at the time of sale in accordance with TI's standard warranty. Testing and other quality control techniques are used to the extent TI deems necessary to support this warranty. Except where mandated by government requirements, testing of all parameters of each product is not necessarily performed.

TI assumes no liability for applications assistance or customer product design. Customers are responsible for their products and applications using TI components. To minimize the risks associated with customer products and applications, customers should provide adequate design and operating safeguards.

TI does not warrant or represent that any license, either express or implied, is granted under any TI patent right, copyright, mask work right, or other TI intellectual property right relating to any combination, machine, or process in which TI products or services are used. Information published by TI regarding third-party products or services does not constitute a license from TI to use such products or services or a warranty or endorsement thereof. Use of such information may require a license from a third party under the patents or other intellectual property of the third party, or a license from TI under the patents or other intellectual property of TI.

Reproduction of TI information in TI data books or data sheets is permissible only if reproduction is without alteration and is accompanied by all associated warranties, conditions, limitations, and notices. Reproduction of this information with alteration is an unfair and deceptive business practice. TI is not responsible or liable for such altered documentation. Information of third parties may be subject to additional restrictions.

Resale of TI products or services with statements different from or beyond the parameters stated by TI for that product or service voids all express and any implied warranties for the associated TI product or service and is an unfair and deceptive business practice. TI is not responsible or liable for any such statements.

TI products are not authorized for use in safety-critical applications (such as life support) where a failure of the TI product would reasonably be expected to cause severe personal injury or death, unless officers of the parties have executed an agreement specifically governing such use. Buyers represent that they have all necessary expertise in the safety and regulatory ramifications of their applications, and acknowledge and agree that they are solely responsible for all legal, regulatory and safety-related requirements concerning their products and any use of TI products in such safety-critical applications, notwithstanding any applications-related information or support that may be provided by TI. Further, Buyers must fully indemnify TI and its representatives against any damages arising out of the use of TI products in such safety-critical applications.

TI products are neither designed nor intended for use in military/aerospace applications or environments unless the TI products are specifically designated by TI as military-grade or "enhanced plastic." Only products designated by TI as military-grade meet military specifications. Buyers acknowledge and agree that any such use of TI products which TI has not designated as military-grade is solely at the Buyer's risk, and that they are solely responsible for compliance with all legal and regulatory requirements in connection with such use.

TI products are neither designed nor intended for use in automotive applications or environments unless the specific TI products are designated by TI as compliant with ISO/TS 16949 requirements. Buyers acknowledge and agree that, if they use any non-designated products in automotive applications, TI will not be responsible for any failure to meet such requirements.

Following are URLs where you can obtain information on other Texas Instruments products and application solutions:

Products

Amplifiers	amplifier.ti.com
Data Converters	dataconverter.ti.com
DLP® Products	www.dlp.com
DSP	dsp.ti.com
Clocks and Timers	www.ti.com/clocks
Interface	interface.ti.com
Logic	logic.ti.com
Power Mgmt	power.ti.com
Microcontrollers	microcontroller.ti.com
RFID	www.ti-rfid.com
RF/IF and ZigBee® Solutions	www.ti.com/lprf

Applications

Audio	www.ti.com/audio
Automotive	www.ti.com/automotive
Broadband	www.ti.com/broadband
Digital Control	www.ti.com/digitalcontrol
Medical	www.ti.com/medical
Military	www.ti.com/military
Optical Networking	www.ti.com/opticalnetwork
Security	www.ti.com/security
Telephony	www.ti.com/telephony
Video & Imaging	www.ti.com/video
Wireless	www.ti.com/wireless

Mailing Address: Texas Instruments, Post Office Box 655303, Dallas, Texas 75265
Copyright © 2009, Texas Instruments Incorporated