

# SPECIFICATION CONTROL DRAWING

82A0114

TITLE	WIRE, RADIATION-CROSSLINKED, MODIFIED FLEXIBLE ETFE-INSULATED, LIGHTWEIGHT, 600 VOLT	Date	9-27-11	Revision	J
-------	--	------	---------	----------	---

This specification sheet forms a part of the latest issue of Raychem Specification 80.

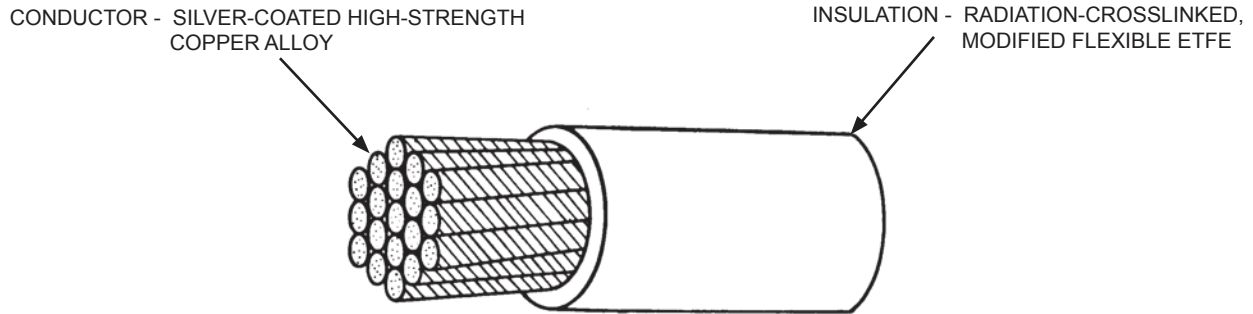

TABLE I. CONSTRUCTION DETAILS

PART NUMBER 1/	WIRE SIZE (AWG)	CONDUCTOR STRANDING (number x AWG)	DIAMETER OF STRANDED CONDUCTOR (in.)		FINISHED WIRE		
			MINIMUM	MAXIMUM	MAXIMUM RESISTANCE AT 20°C (ohms/1000 ft.)	DIAMETER (in.)	MAXIMUM WEIGHT (lbs/1000 ft.)
82A0114-28-*	28	42 x 44	.013	.017	84.5	.029 ± .003	1.0
82A0114-26-*	26	63 x 44	.017	.021	55.9	.033 ± .003	1.4
82A0114-24-*	24	105 x 44	.023	.027	36.5	.037 ± .003	2.1
82A0114-22-*	22	154 X 44	.029	.033	23.5	.043 ± .003	2.9

TABLE II. PERFORMANCE DETAILS

PART NUMBER 1/	BEND TESTING	
	MANDREL DIAMETER (inch) (± 3%)	WEIGHT (lb) (± 3%)
	CROSSLINKING PROOF TEST	CROSSLINKING PROOF TEST
	82A0114-28-*	.250
82A0114-26-*	.375	.125
82A0114-24-*	.375	.250
82A0114-22-*	.500	.375

Users should evaluate the suitability of this product for their application. Specifications are subject to change without notice. Tyco Electronics Corporation also reserves the right to make changes in materials or processing, which do not affect compliance with any specification, without notification to Buyer.

1/ COLORS AND COLOR CODE DESIGNATORS SHALL BE IN ACCORDANCE WITH MIL-STD-681. OTHER CODES AND SUFFIXES MAY BE ADDED TO THE PART NUMBER, AS NECESSARY, TO CAPTURE ANY ADDITIONAL REQUIREMENTS IMPOSED BY THE PURCHASE ORDER.

Raychem, TE Connectivity, TE connectivity (logo) and TE (logo) are trademarks.

DIMENSIONS ARE IN INCHES, AND UNLESS OTHERWISE DESIGNATED ARE NOMINAL.

THIS SPECIFICATION SHEET TAKES PRECEDENCE OVER DOCUMENTS REFERENCED HEREIN. REFERENCED DOCUMENTS SHALL BE OF THE ISSUE IN EFFECT ON DATE OF INVITATION FOR BID.



Raychem Wire & Cable  
501 Oakside Avenue  
Redwood City, CA 94063-3800  
Phone: 1-800-227-8816  
Fax: 1-650-361-6297



## WIRE RATINGS AND ADDITIONAL REQUIREMENTS

TEMPERATURE RATING: 150°C

Maximum continuous conductor temperature

VOLTAGE RATING: 600 volts (rms) at sea level

COLOR: White preferred

CONCENTRICITY: 70% (minimum)

CROSSLINKING PROOF TEST: 300 ± 3°C for 30 minutes

IDENTIFICATION AND COLOR STRIPING DURABILITY:

125 cycles (250 strokes) (minimum), 500 gram weight

INSULATION ELONGATION AND TENSILE STRENGTH:

AWG 28-26: Elongation, 75% (minimum)

Tensile Strength, 3000 lbf/in<sup>2</sup> (minimum)

AWG 24-22: Elongation, 75% (minimum)

Tensile Strength, 3500 lbf/in<sup>2</sup> (minimum)

INSULATION FLAWS:

Spark Test, 1.5 kV (rms) at 3 kHz

Impulse Dielectric Test, 6.0 kV (peak)

INSULATION THICKNESS: .004 in. (minimum)

PRODUCT IDENTIFICATION: black ink only

SECANT MODULUS (Test per ASTM D 882): 5.0 x 10<sup>4</sup> lbf/in<sup>2</sup> (maximum)

2% strain, 2 inch jaw separation, 0.2 inch/minute

SHRINKAGE: 150 ± 3°C for 6 hours, 0.13 in. (maximum) in 12 inches

VOLTAGE WITHSTAND (Post Environmental): 2500 volts (rms), 60 Hz

PART NUMBER:

The "\*" in the part numbers on page 1 shall be replaced by a color code designator.

1/ Example: AWG 24, white; 82A0114-24-9

AWG 24, white with a black stripe; 82A0114-24-90

1/ See footer section on page 1