

2500W 1U Front End Power Supplies

<https://product.tdk.com/en/power/hfe>
www.emea.lambda.tdk.com/uk/products/hfe

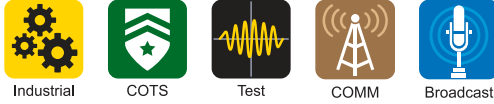

The HFE2500 AC-DC industrial power supplies can be operated in a hot-swap redundant configuration, or used to provide up to 9,500W of bulk power. Up to four power supplies can be fitted in a variety of 19" 1U high racks, for configuration as a single output. The HFE supplies have internal ORing MOSFETs and current share for automatic parallel operation. Communication is possible with the power supplies using the optional isolated PMBus™ (I²C) interface or a plug-in LAN module. AC fail, DC good, remote output adjust, remote on/off and a 12V auxiliary output are fitted as standard.

Features	Benefits
• Internal ORing MOSFET and Current Share	• Suitable For N+1 Redundancy
• Up to 9500W in 1U Rack	• Utilizes Less System Space
• Full Array of Signals Available	• Easy Remote Monitoring
• PMBus™ (I ² C) and LAN options	• Industry Standard Communication Interfaces
• Analog Output Adjustment	• Simple External Resistance or Voltage Connection

Model Selector						
Model	Output Voltage (V)	Adjustment Range (V) ⁽¹⁾	Max Current (A) (Vin>180Vac)	Max Power (W) (Vin>180Vac)	Max Current (A) (100<Vin<170Vac) ⁽²⁾	Max Power (W) (100<Vin<170Vac) ⁽²⁾
HFE2500-12	12	9.6 - 13.2	200	2400	125	1500
HFE2500-24	24	19.2 - 29	104	2496	62.5	1500
HFE2500-48	48	38.4V - 58	52	2496	31.25	1500

HFE2500-	12	/	S
	Output voltage 12, 24, 48		blank No PMBus™ / I ² C S PMBus™ / I ² C interface

Model Selector (Racks and LAN)		
Model	Description	Maximum Rack Current
HFE2500-S1U	Four slot 19" rack, IEC320-C20 input connectors (4)	320A each side (640A total)
HFE2500-S1U-TB	Four slot 19" rack, Terminal Block input connectors (4)	320A each side (640A total)
HFE2500/BP	One slot blanking panel, three panels come with each rack	
HFE/C19-U-O	AC Power cord, 2.0m long, one per supply required	
HFE2500-LAN	Plug in LAN Module. Takes up one rack slot. For use with /S power supplies only.	

Specifications		HFE2500-12	HFE2500-24	HFE2500-48
Input				
AC Input Voltage Range (Operating) ⁽²⁾	Vac	85 - 265, See model selector for power derating		
Nominal Input Voltage Range	Vac	100 - 240 (Note: Safety certified for 90 - 264Vac only)		
Input Frequency	Hz	47 - 63		
Input Current (Max) 100/230Vac	A	15 / 12		
Inrush Current	A	<50		
Leakage Current 100/230Vac, 60Hz	mA	<0.75 / 1.5		
Power Factor Correction	-	Meets EN61000-3-2, PF > 0.98 at full load		
Harmonic Compliance	-	Meets IEC61000-3-2		
Hold-Up Time 115/230Vac, 60Hz	ms	>10, 80% loading		
Efficiency (3)	%	90 / 92	90 / 92	91 / 93
Conducted EMI	-	Designed to meet EN55032-B, FCC Class B, VCCI-B		
Radiated EMI	-	Designed to meet EN55032-A, FCC Class A, VCCI-A		
Immunity	-	See immunity section		
Safety Certifications and Markings	-	IEC/UL/CSA/EN62368-1, 60950-1, CE Mark and UKCA Mark		

Immunity				
Test	Standard	Test Level	Criteria	Notes
ESD	EN61000-4-2	2,3	B	-
Radiated Susceptibility	EN61000-4-3	2	A	-
Electrical Fast Transient Burst	EN61000-4-4	2	B	-
Surge	EN61000-4-5	3,4	B	-
Conducted Susceptibility	EN61000-4-6	2	A	-
Magnetic fields	EN61000-4-8	4	A	-
Voltage Dips and Input Interruptions	EN61000-4-11	>95% for 0.5 cycles	B	-
		30% for 25/30 cycles	C	-
		>95% for 250/300 cycles	C	-

Specifications		HFE2500-12	HFE2500-24	HFE2500-48
Output				
Line Regulation	mV	30	60	120
Load Regulation	mV	60	120	240
External Load Capacitance	uF		1000/A	
Ripple & Noise (1)	mV	240	240	480
Temperature Coefficient	%/°C		<0.02	
Minimum Load	-	No minimum load required		
Overcurrent Protection	%	105-115		
Overvoltage Protection (1)	%	110% (Tracking). Cycle AC to reset or utilize Remote On/Off		
Overtemperature Protection (1)	-	Shutdown with automatic reset. Warning signal provided		
Remote Sense Compensation	V/wire	0.25	0.5	1.0
Remote On/Off	-	Unit ON: 0-0.6V or short, OFF: 2-15V or open circuit		
Remote Adjust (1)	-	By either external 0-5V signal or 1k potentiometer		
AC Fail Signal	-	Open Collector, ON when AC is within 85-270Vac		
DC Good Signal	-	Open Collector, ON when output is above 85 to 95% of setpoint (tracking)		
Auxiliary Output	-	11.2 - 12.5V, 0.5A, 240mV ripple and noise		
Communication	-	Optional isolated PMBus™ (I2C) interface (/S suffix) or plug-in LAN module. See model selectors		
Indicators	-	AC OK: Green LED, DC OK / Fail: Green / Red LED		
Parallel Operation (1)	-	Yes, single wire current share, up to 95% accuracy (load dependent), up to 8 units		

Specifications			
Model	HFE2500-12	HFE2500-24	HFE2500-48
Environmental			
Operating Temperature	°C	-10 to +50: 100% load; +50 to +60 derate: 2%/°C of load; +60 to +70 derate: 2.5%/°C of load. For models with reverse air contact factory.	
Storage Temperature	°C	-30 to +85	
Humidity (non condensing)	%RH	Operating: 10 - 90, Storage: 10 - 95	
Cooling	-	Internal variable speed fans. Airflow enters from the front. (4)	
Altitude	m	3000 max. Derate output current 2%/100m above 2000m.	
Withstand Voltage	-	I/P to O/P 3kVac, I/P to GND 2kVac. O/P to GND: HFE2500-12, -24V 500Vac, HFE2500-48 2250Vdc 1 min, (POE)	
Isolation Resistance	MΩ	>100 at 25°C & 70%RH, Output to Ground 500Vdc	
Vibration (Non-operating))	-	Meets IEC60068-2-64 (Basic Transportation)	
Shock (Non-operating)	-	Meets IEC60068-2-27 (Basic Transportation)	
Other			
Weight (Typ)	g	Power Supply: 2100, Rack: 5000	
Size (LxWxH)	mm	Power supply: 325 x 107 x 40.1; Rack: 477.5 x 444.5 x 43.7	
Size (LxWxH)	Inches	Power Supply: 12.8 x 4.21 x 1.61; Rack: 15.8 x 17.5 x 1.72	
PMBus™ / I ² C Interface (1)	-	Isolated from output, Add suffix /S, PMBus™ compatible	
MTBF - Telcordia	Hours	219,557	
Warranty	yrs	Three	

Notes

- (1) See installation manual for detailed specifications & test methods
- (2) Derate linearly 1.3%/V from 100Vac to 85Vac input
- (3) At 75% load, 100 / 230Vac input
- (4) Reverse air - contact factory

Outline Drawing HFE2500

REAR VIEW

IN/OUT CONNECTOR REAR VIEW

PIN No.	FUNCTION	PIN No.	FUNCTION
A1-A10	-VO	B14	A1 (PM BUS)
A11-20	+VO	B15	DC_OK
B1	SIGNAL_RTN	B16	A0 (PM BUS)
B2	PS_EXIST	B17	SDA (PM BUS)
B3	+12V_AUX_OUT	B18	TEMP_ALM_SR
B4	-SENSE	B19	V_REF_EXT
B5	A2 (PM BUS)	B20	SMB_ALERT (PM BUS)
B6	CS	B21	AC_FAIL_OUT
B7	ENABLE	B22	5V_Trim
B8	V_PROG	B23	NC
B9	+SENSE_IN	B24	NC
B10	A3 (PM BUS)	C1	GND
B11	I_PROG	C2	NEUTRAL
B12	INHIBIT	C3	LINE
B13	SCL (PM BUS)		

NOTES:

- CONNECTOR TYPE: PC1H47M40DA1/AA, POSITRONIC.
- MATES WITH FEMALE CONNECTOR TYPE: PC1H47F40DA1/AA
- LED INDICATORS REFER TO INSTRUCTION MANUAL
- MOUNTING SCREWS MUST NOT PENETRATE MORE THAN 7mm INTO THE UNIT.
- LABEL WITH MODEL NAME, INPUT AND OUTPUT RATING, SAFETY APPROVAL SYMBOLS AND PLACE FOR DATA CODE AND EU REPRESENTATIVE ADDRESS LABEL.
- ALLOW MINIMUM 50mm OF FREE AIR OUTLET AT THE REAR OF THE UNIT. DO NOT OBSTRUCT AIR FLOW TO THE FRONT PANEL.
- REFER TO INSTRUCTION MANUAL FOR SETTING DETAILS.
- TO EXTRACT THE POWER SUPPLY, ELEVATE THE RELEASE KNOB AND PULL THE EXTRACTION HANDLE.

TOLERANCES:

TOLERANCES:±	
1-16mm	0.1
16.1-63mm	0.2
63.1-250mm	0.3
250.1-1000mm	0.5
ANGLE	±0.3°

Outline Drawing HFE2500-S1U

NOTES:

- MOUNTING HOLES FOR RACK 19". USE M6x12 SCREWS TO FIX THE UNIT TO A RACK.
- USE NUT, FLAT WASHER AND SPRING WASHER FOR LOAD WIRES FIXING. USE LUG STUD M6 FOR LOAD WIRES. RECOMMENDED TORQUE: 42-56 kgf.cm.
- TO FIX THE MOUNTING BRACKET TO THE CHASSIS USE M5x10 SEMS SCREWS. RECOMMENDED TIGHTENING TORQUE 27-33kgf.cm. SCREWS MUST NOT PENETRATE THE CHASSIS MORE THAN 6.0mm.
- REFER TO INSTRUCTION MANUAL FOR SETTING DETAILS.
- MODEL NAME, VOLTAGE AND CURRENT RATINGS AND SAFETY APPROVALS SYMBOLS WILL BE SHOWN HERE ACCORDING TO THE SPECIFICATION.
- THE HFE2500 RACK IS SHOWN WITH 4 HFE2500 UNITS INSTALLED.
- THE IEC INLET - TYPE C20
- EU REPRESENTATIVE ADDRESS LABEL
- IEC 60417-6042 AND IEC 60417-6172 SAFETY SYMBOLS LABELS.

SIGNALS & CONTROL CONNECTOR PINS ASSIGNMENT

1 SENSE	11 TEMP_ALM_A	21 DC_OK_A	31 NC
2 LS	12 TEMP_ALM_B	22 DC_OK_B	32 PS_EXIST_A
3 +SENSE	13 TEMP_ALM_C	23 DC_OK_C	33 PS_EXIST_B
4 +LS	14 TEMP_ALM_D	24 DC_OK_D	34 PS_EXIST_C
5 V_PROG	15 NC	25 NC	35 PS_EXIST_D
6 TRIM	16 AC_FAIL_A	26 SIGNAL RETURN	36 NC
7 I_PROG	17 AC_FAIL_B	27 INHIBIT_A	37 SIGNAL RETURN
8 5V_TRIM	18 AC_FAIL_C	28 INHIBIT_B	38 +12V_AUX
9 V_REF	19 AC_FAIL_D	29 INHIBIT_C	39 ENABLE
10 SENSE	20 NC	30 INHIBIT_D	40 SIGNAL RETURN

CONNECTOR DESCRIPTION: IP1-120-01-S-D-RA-K(SAMTEC)
MATING CONNECTOR: IPD1-20-D-K(SAMTEC)

ACCESSORIES LIST IN SHEET 2

Outline Drawing HFE2500-S1U-TB

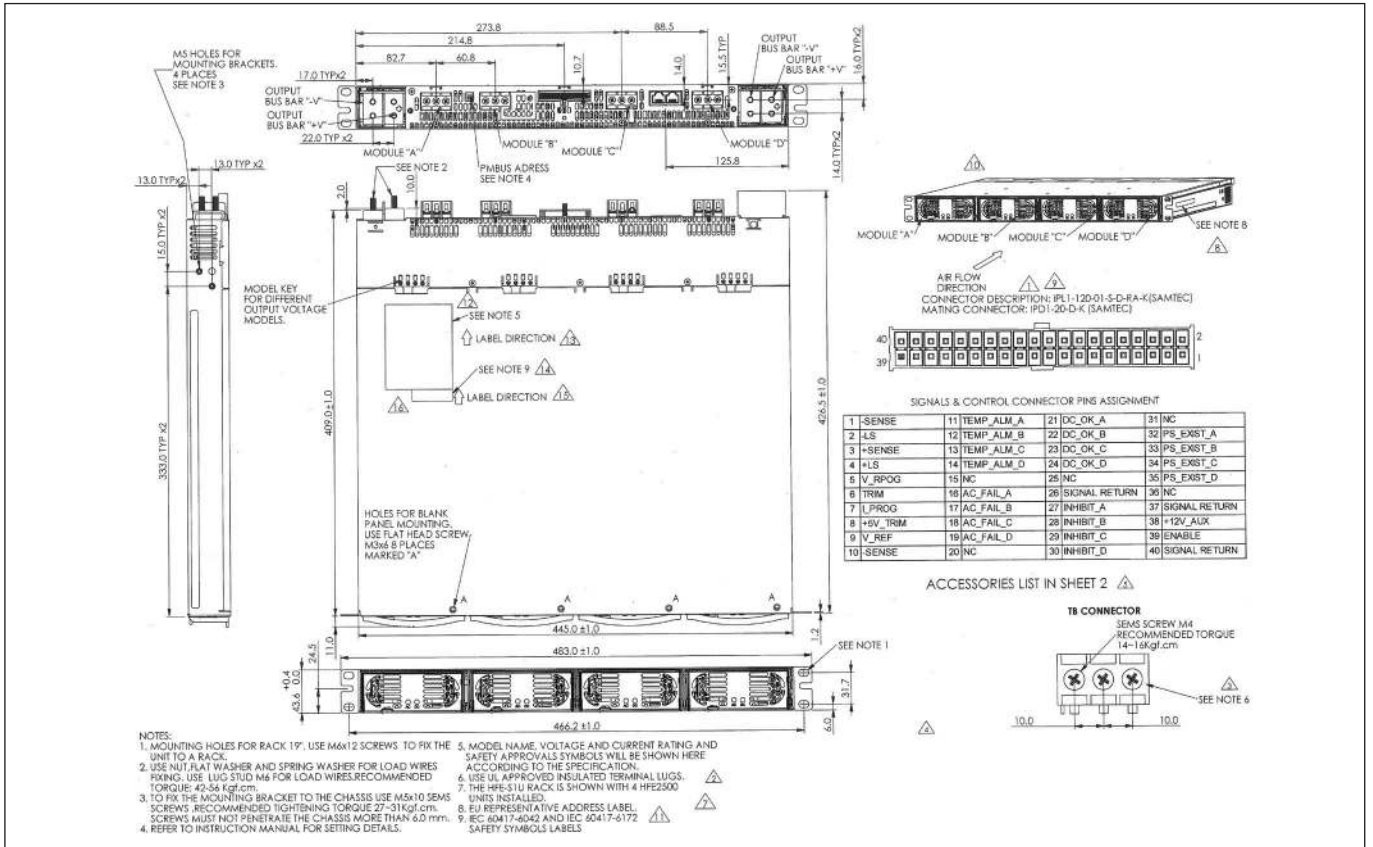

Outline Drawing HFE2500-LAN

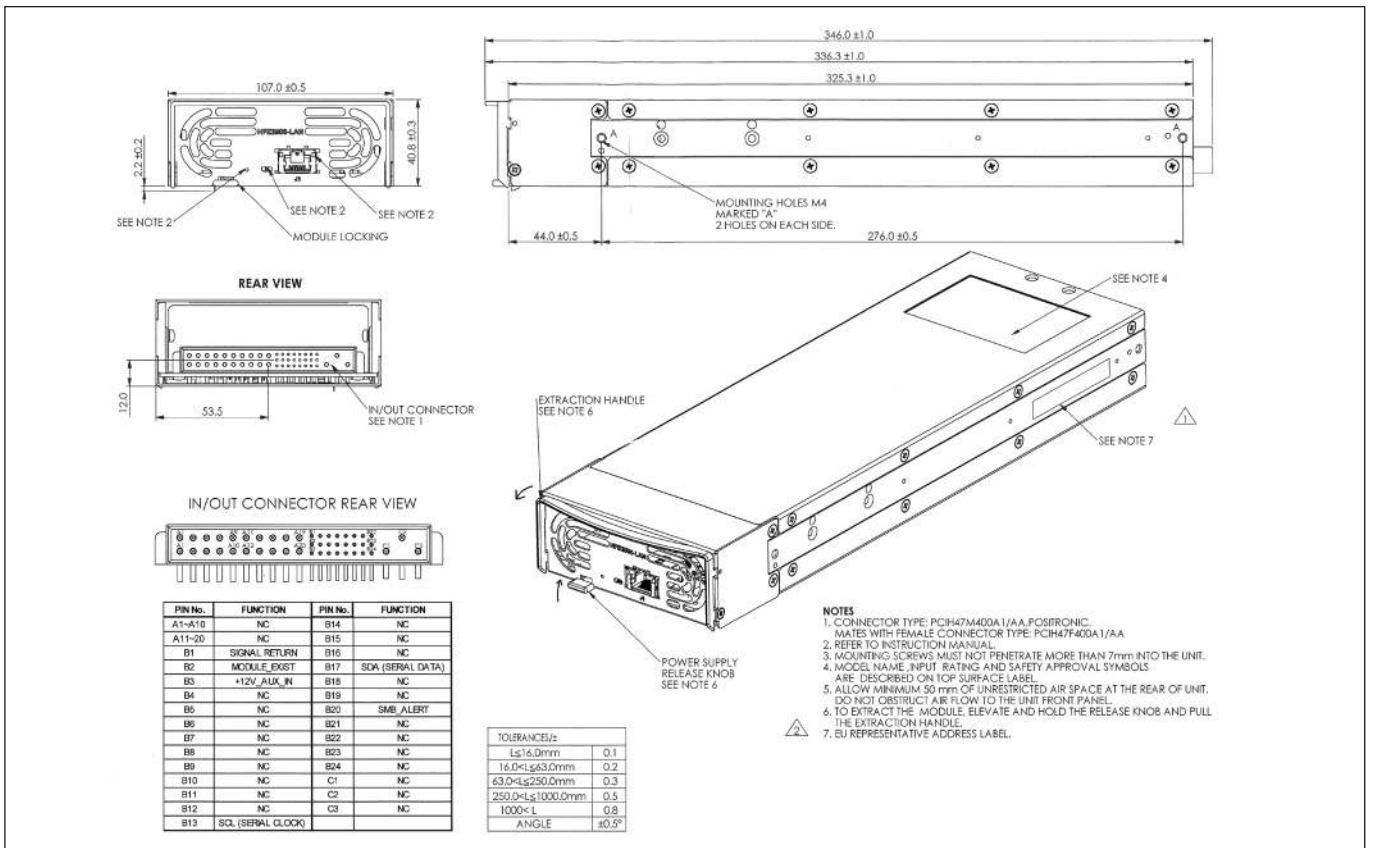



TDK-Lambda France SAS

Tel: +33 1 60 12 71 65
 ttf.fr.powersolutions@tdk.com
 www.emea.lambda.tdk.com/fr



Italy Sales Office

Tel: +39 02 61 29 38 63
 ttf.it.powersolutions@tdk.com
 www.emea.lambda.tdk.com/it



Netherlands

ttf.nl.powersolutions@tdk.com
 www.emea.lambda.tdk.com/nl



TDK-Lambda Germany GmbH

Tel: +49 7841 666 0
 tlg.powersolutions@tdk.com
 www.emea.lambda.tdk.com/de



Austria Sales Office

Tel: +43 2256 655 84
 tlg.at.powersolutions@tdk.com
 www.emea.lambda.tdk.com/at



Switzerland Sales Office

Tel: +41 44 850 53 53
 tlg.ch.powersolutions@tdk.com
 www.emea.lambda.tdk.com/ch



Nordic Sales Office

Tel: +45 8853 8086
 tlg.dk.powersolutions@tdk.com
 www.emea.lambda.tdk.com/dk



TDK-Lambda UK Ltd.

Tel: +44 (0) 12 71 85 66 66
 tlu.powersolutions@tdk.com
 www.emea.lambda.tdk.com/uk



TDK-Lambda Ltd.

Tel: +9 723 902 4333
 tli.powersolutions@tdk.com
 www.emea.lambda.tdk.com/il-en



TDK-Lambda Americas

Tel: +1 800-LAMBDA-4 or 1-800-526-2324
 tia.powersolutions@tdk.com
 www.us.lambda.tdk.com



TDK Electronics do Brasil Ltda

Tel: +55 11 3289-9599
 sales.br@tdk-electronics.tdk.com
 www.tdk-electronics.tdk.com/en



TDK-Lambda Corporation

Tel: +81-3-6778-1113
 www.jp.lambda.tdk.com



TDK-Lambda (China) Electronics Co. Ltd.

Tel: +86 21 6485-0777
 tlc.powersolutions@tdk.com
 www.lambda.tdk.com.cn



TDK-Lambda Singapore Pte Ltd.

Tel: +65 6251 7211
 tis.marketing@tdk.com
 www.sg.lambda.tdk.com



TDK India Private Limited, Power Supply Division

Tel: +91 80 4039-0660
 mathew.philip@tdk.com
 www.sg.lambda.tdk.com

