

THIS DOCUMENT IS THE PROPERTY OF KEYSTONE ELECTRONICS CORP. AND SHALL NOT BE REPRODUCED, DISTRIBUTED OR USED AS A BASIS FOR MANUFACTURE WITHOUT PRIOR WRITTEN PERMISSION FROM KEYSTONE ELECTRONICS CORP.

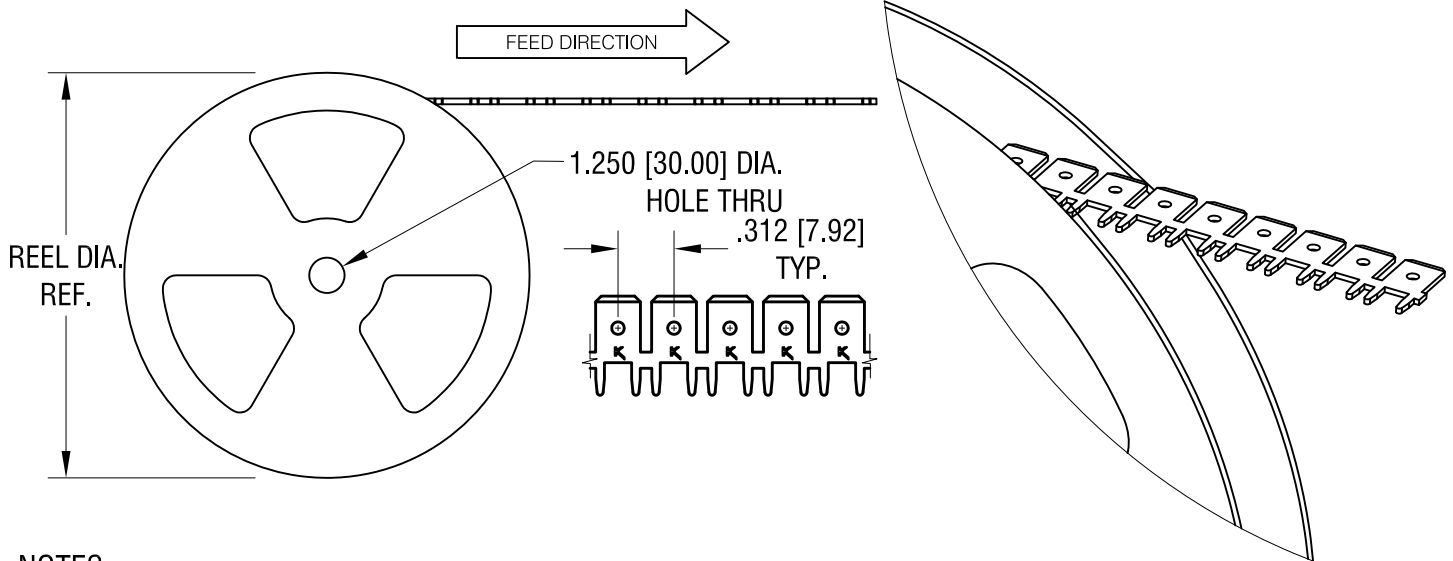
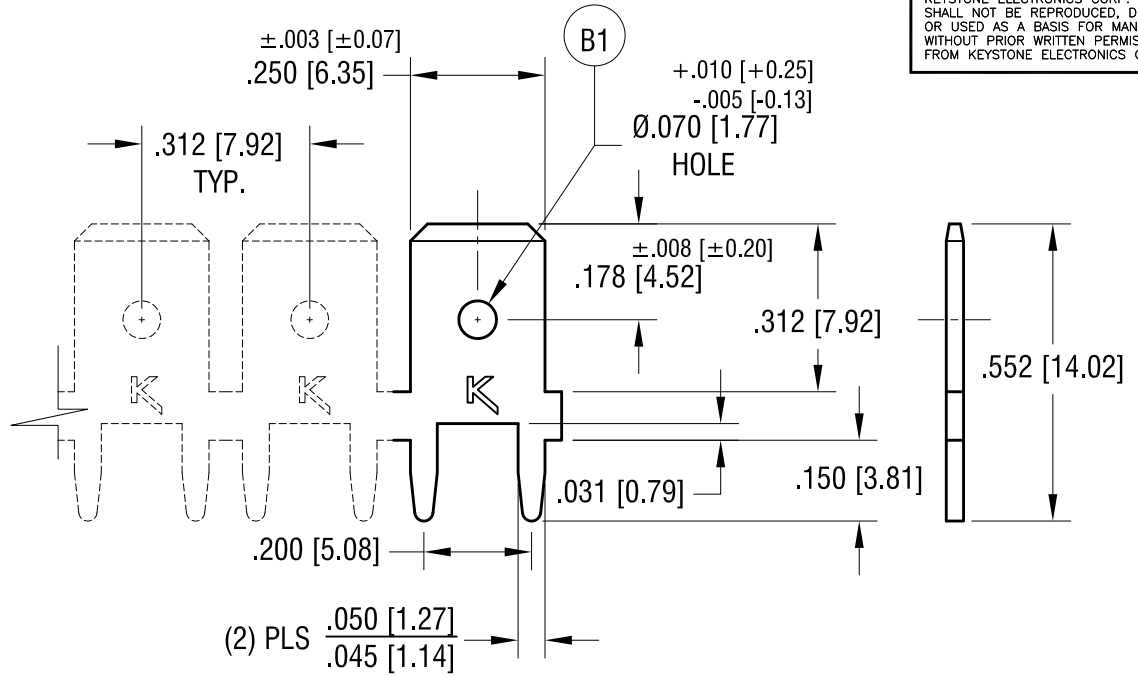

**NOTES:**

**REEL SPECIFICATIONS:**

1. REEL: CARDBOARD  
15.0 [380.8] DIA. 12,500 PIECES PER CONTINUOUS REEL.

**TERMINAL SPECIFICATIONS:**

1. MAT'L- .032 [0.81] BRASS
2. FINISH: MATTE TIN PLATE.

11.02.22	FLIP PARTS POSITION ON REEL CHANGE AS PER ECN 22-168	C
10.13.21	(B1) WAS Ø.070 [1.77]±.005 CHANGE AS PER ECN 21-112	B
3.01.18	WAS 10,000 PCS PER REEL CHANGE AS PER ECN 19-030	A
DATE	DESCRIPTION	REV.

<b>KEYSTONE ELECTRONICS CORP.</b>			
www.keyelco.com • NEW HYDE PARK, NY 11040 • Tel (516) 328-7500			
PART NAME		PC QUICK FIT TERMINAL - CONTINUOUS REEL	
MATERIAL		AS NOTED	
FINISH		DRN BY	DATE
AS NOTED		NT	4.12.18
		APP'D	SCALE
		LN	3X, 1X
TOLERANCES	INCH [MM]	CODE	DWG NO.
DECIMAL	± .005 [± 0.13]	C	1287-R
ANGULAR	± 1°		
UNLESS OTHERWISE SPECIFIED			