

# XMC1400 Boot Kit

## For XMC1000 Family

### About this document

#### Scope and purpose

This document provides the schematic and hardware description of XMC1400 Boot Kit, so that user is able to make use of this board for their application code development on XMC1404-Q064X0200 device.

#### Intended audience

For people who are interested to explore the functionality of XMC1404 device.

### Table of Contents

<b>About this document.....</b>	<b>1</b>
<b>Table of Contents .....</b>	<b>1</b>
<b>1 Overview .....</b>	<b>2</b>
1.1 Key Features .....	2
1.2 Block Diagram .....	2
<b>2 Hardware Description .....</b>	<b>3</b>
2.1 Power Supply.....	4
2.2 Reset .....	5
2.3 Clock Generation .....	5
2.3.1 External Crystal and external Real time Clock crystal .....	5
2.4 Boot Option .....	7
2.5 CAN bus connector.....	7
2.6 Debug Interface and virtual com port .....	8
2.7 LED .....	9
2.8 Potentiometer .....	9
2.9 Application Card connector .....	10
<b>3 Production Data .....</b>	<b>11</b>
3.1 Schematics .....	11
3.2 Layout and Geometry.....	14
3.3 CR number of XMC1400 Boot Kit.....	15
3.4 Bill of Material.....	16
<b>Revision History .....</b>	<b>18</b>

## **1 Overview**

This document describes the features and hardware details of the XMC1400 Boot Kit. This board is mounted with ARM® Cortex®-M0 based XMC1400 Microcontroller from Infineon Technologies AG. This board is part of Infineon's XMC1000 Application Kits.

The XMC1400 Boot Kit (CPU-14A-V1) houses the XMC1400 Microcontroller and a 2x30 pin edge for application expansion. The board along with application cards (e.g. Colour LED Card, White LED Card) demonstrates the capabilities of XMC1400. The main use case for this board is to demonstrate the generic features of XMC1400 device, including tool chain. The focus is safe operation under evaluation conditions. The board is neither cost nor size optimized and does not serve as a reference design.

### **1.1 Key Features**

The XMC1400 Boot Kit is equipped with the following features

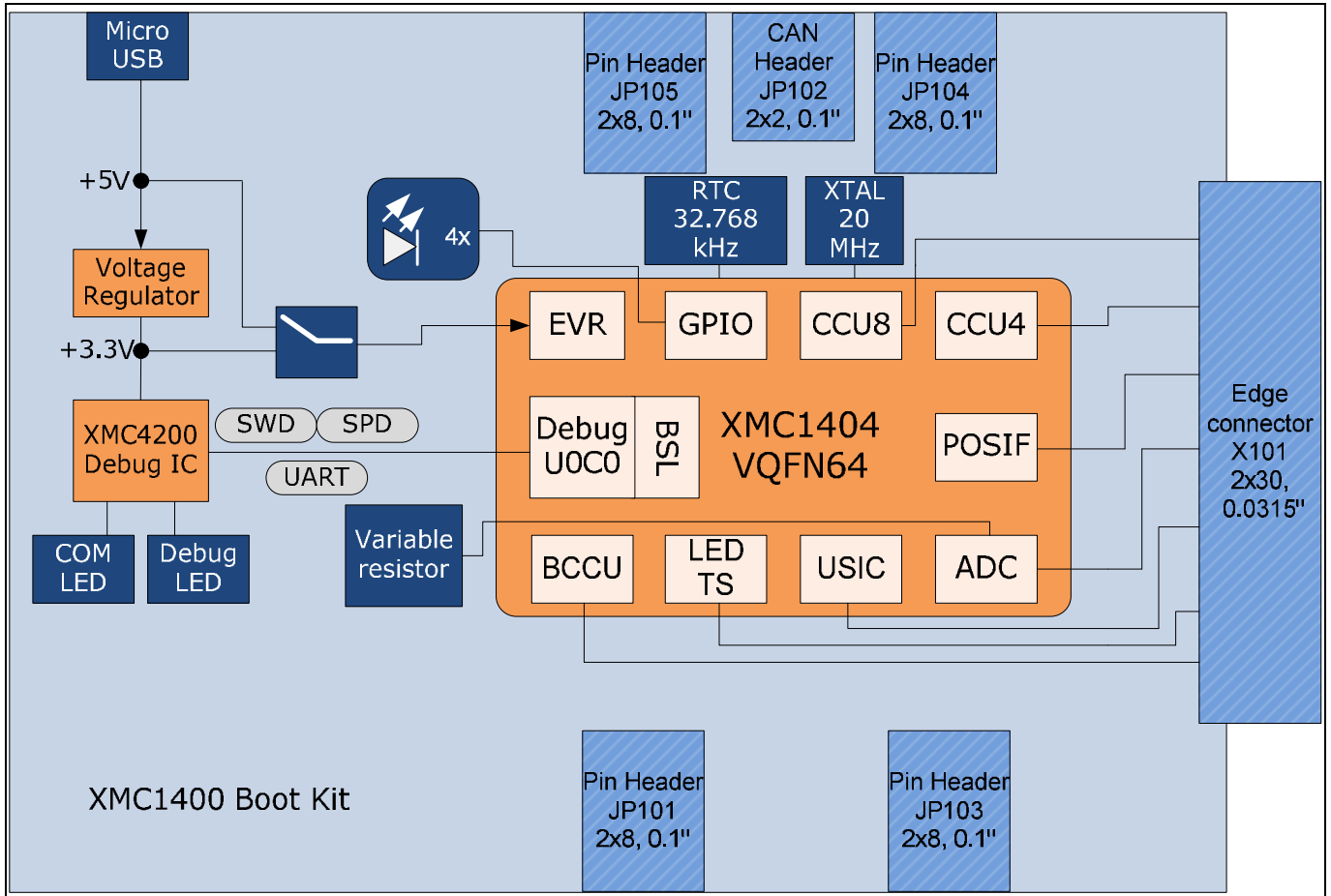
- XMC1400 (ARM®Cortex®-M0 based) Microcontroller, VQFN64
- Connection to application cards via card edge connector
- Detachable J-Link debugger and UART virtual COM port, with micro USB connector
- Four user LEDs
- Potentiometer, connected to analog input P2.5
- Power supply via Micro-USB connector
- Usage of 20MHz external crystal for CAN communication
- Usage of 32.768 kHz external crystal as standby clock

### **1.2 Block Diagram**

Figure 1 shows the functional block diagram of the XMC1400 Boot Kit.

Features include:

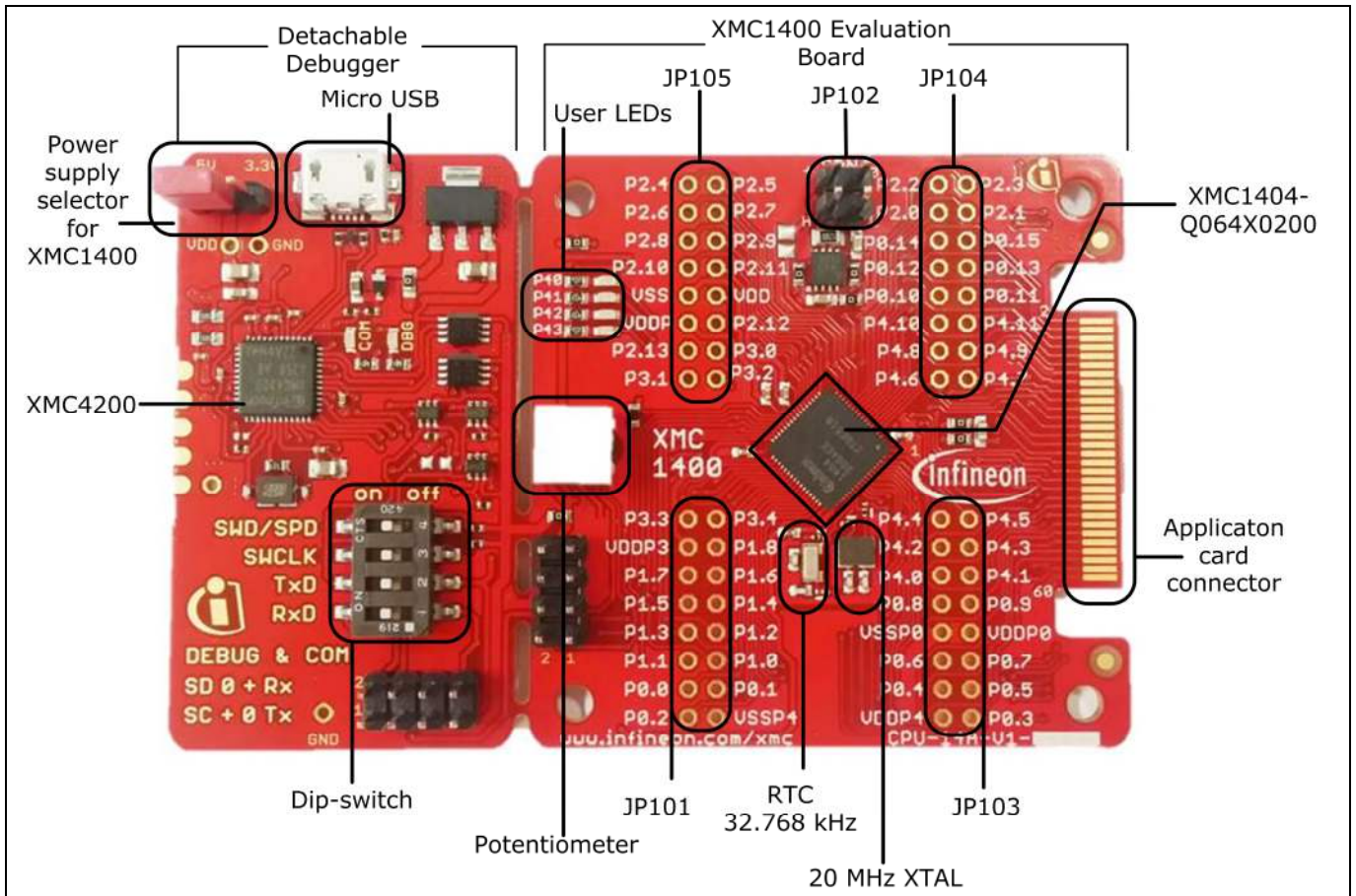
- On board Debugger for downloading and debugging of application code
- Virtual COM port for UART communication with terminal program e.g. Hyperterminal
- 2x30 card edge connector for extension to application card e.g. Colour LED Card and White LED Card
- 4 User LEDs connected to GPIO P4.0, P4.1, P4.2, P4.3
- Variable resistor R110 connected to analog input P2.5
- All the pins of XMC1400 are accessible via the connector JP101, JP103, JP104 and JP105
- CAN interface with CAN transceiver mounted
- External crystal 20 MHz and 32.768 kHz mounted



**Figure 1 Block Diagram of XMC1400 Boot Kit**

## 2 Hardware Description

The following sections give a detailed description of the hardware and how it can be used.

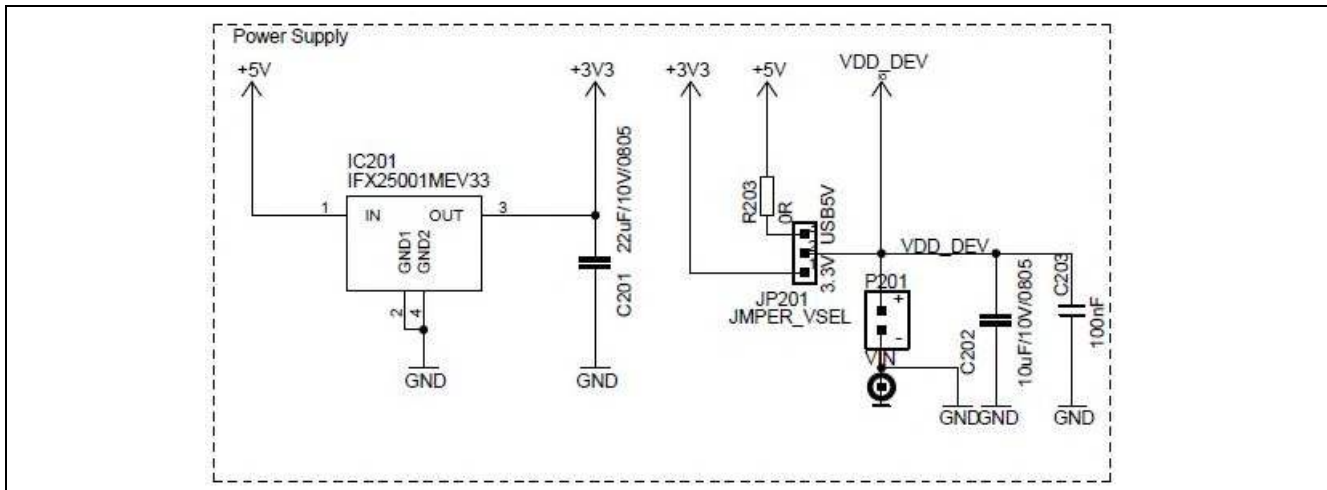


**Figure 2 XMC1400 Boot Kit**

## 2.1 Power Supply

XMC1400 Boot Kit is powered from the micro USB connector (+5V); however, there is a current limit that can be drawn from the host PC through USB. If the CPU-14A-V1 board is used to drive other application board (e.g. Colour LED Card, White LED Card) and the total current required exceeds 500mA, then the board needs to be powered by external power supply connected to VDD and GND connection on board.

The XMC1404 device can operate by power supply of 1.8V till 5.5Vdc. On this board 5Vdc is used to power the XMC1404 device. However, if the user wants to power the XMC1404 device with 3.3Vdc, then set jumper at JP201 to 3.3V side.



**Figure 3 Power Supply circuit**

## 2.2 Reset

Since XMC1404 does not have a reset pin, the user can unplug and replug the USB cable to achieve power-on master reset.

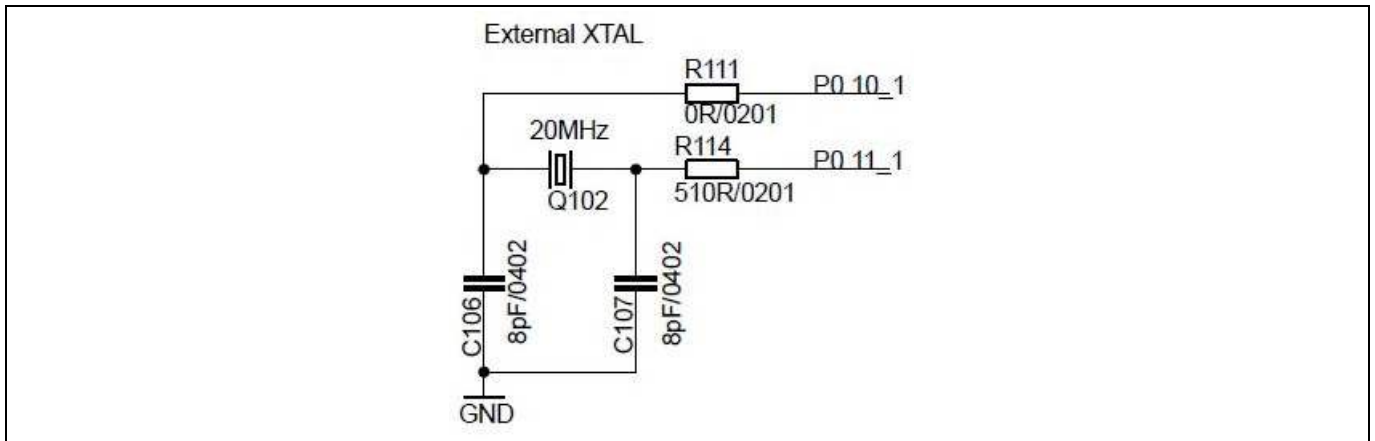
## 2.3 Clock Generation

XMC1404 has two internal oscillators: DCO1 and DCO2. DCO1 has a clock output of 96 MHz. DCO2 is used to generate the standby clock running at 32.768 kHz which used for Real Time Clock too. The main clock, MCLK and fast peripheral clock, PCLK, are generated from the output of DCO1.

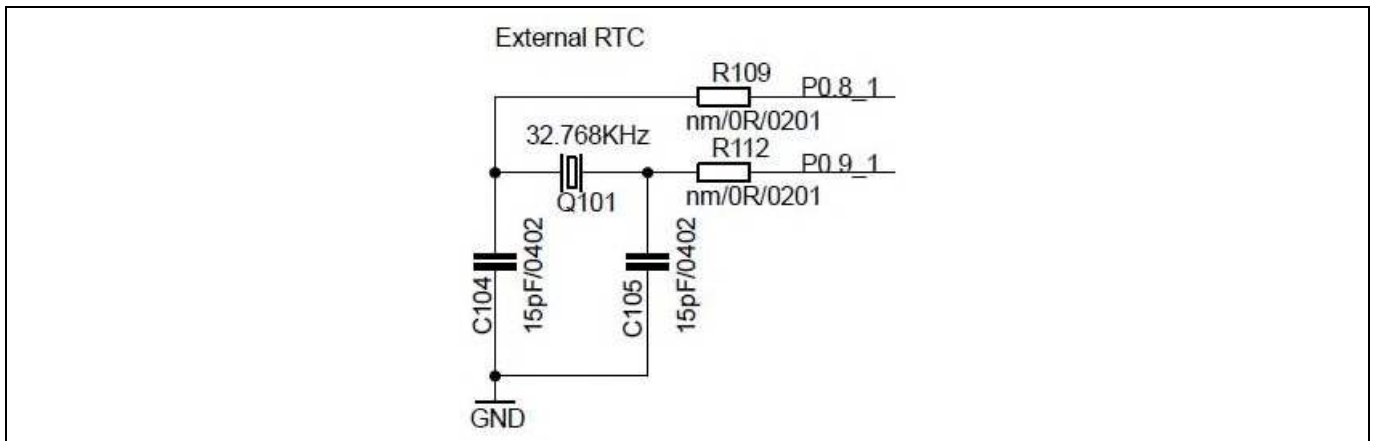
### 2.3.1 External Crystal and external Real time Clock crystal

The XMC1400 device allows its main clock MCLK to be generated from external crystal to achieve higher accuracy. It also allows its real time clock to be run from external RTC crystal. On the XMC1400 Boot Kit, a 20 MHz external crystal circuit and a 32.768 kHz RTC external crystal circuit are implement on board to allows user to run its application using external crystals. The 20 MHz crystal Q102 is connected to the XMC1404 device via R111 and R114. If user does not want to use the external 20MHz crystal Q102 but wish to use P0.10 and P0.11 as general purpose pins, then R111 and R114 need to be desoldered while R113 and R115 soldered.

The 32.768 kHz crystal Q101 is not connected to the XMC1404 device. If user wants to use the external 32.768 kHz crystal, the two 0 ohm resistors R109 and R112 need to be soldered while R108 and R110 need to be desoldered. Please refer to Figure 6 for locations of these 0 ohm resistors.

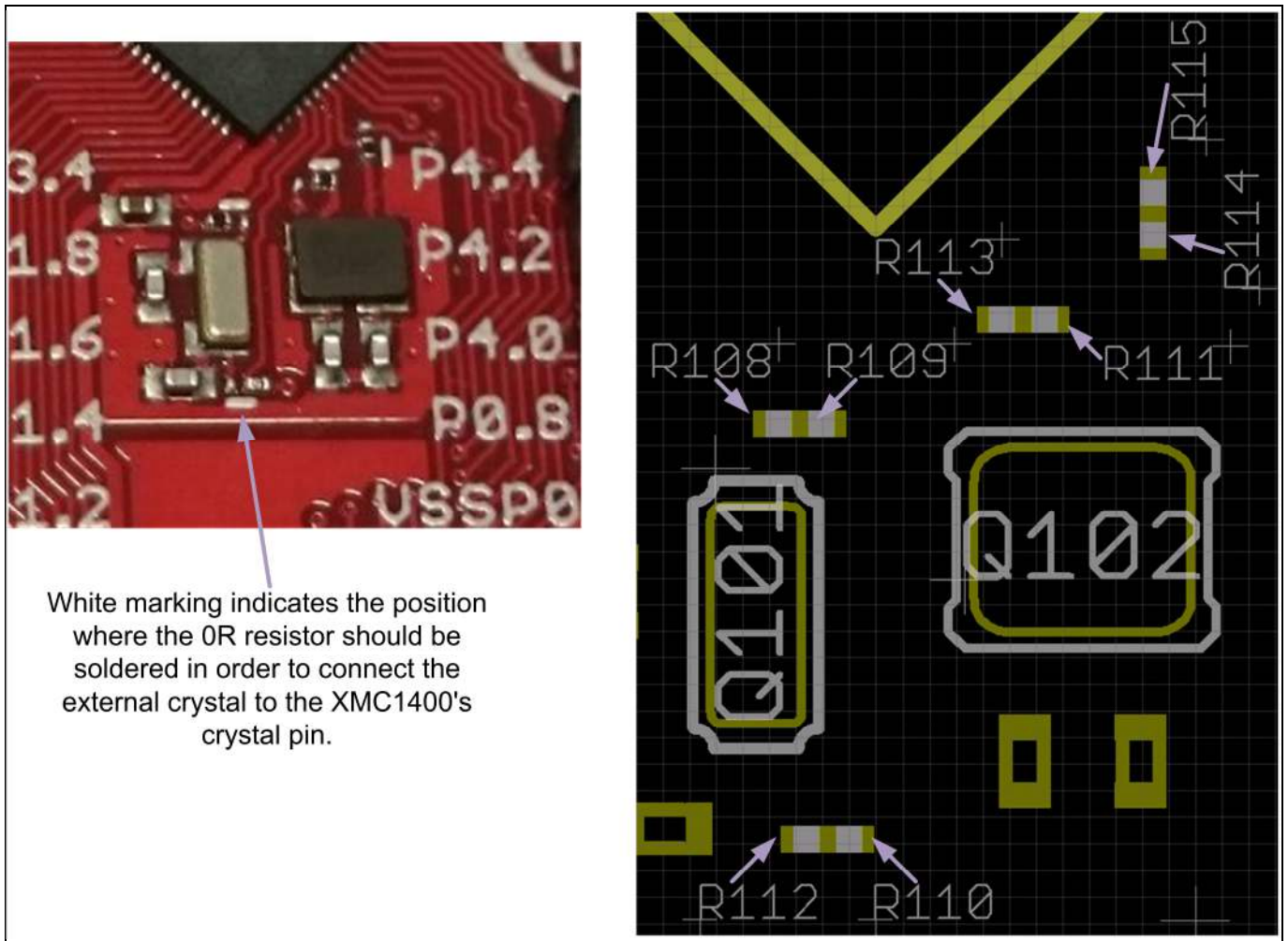


**Figure 4** The external 20 MHz crystal



**Figure 5** The external 32.768 kHz RTC crystal





**Figure 6 The positions of 0 ohm resistors for connection of external crystals to XMC1400 device**

## 2.4 Boot Option

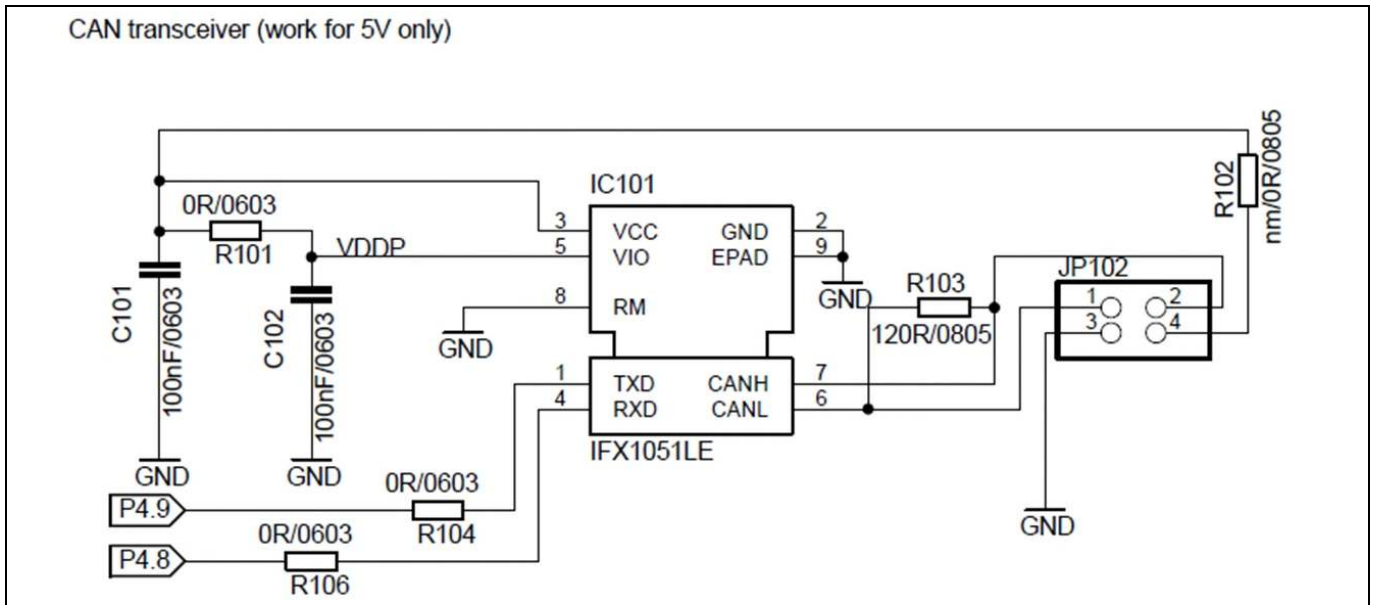
After power-on reset with master reset, XMC1404 device enters different boot modes depending on the BMI (Boot Mode Index) value stored in flash configuration sector 0 (CS0). The BMI value pre-programmed in the XMC1404 on Boot Kit is User mode with debug enabled, hence, the XMC1404 device will start to run the application code in its embedded flash after power on reset.

## 2.5 CAN bus connector

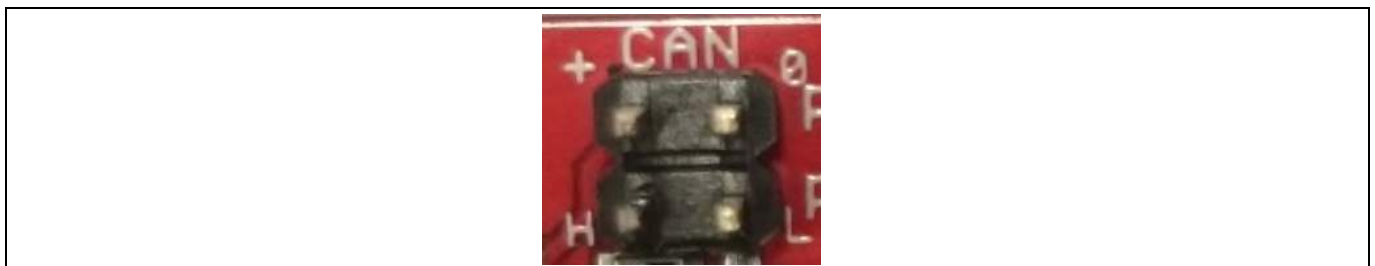
A CAN bus header connector is provided for CAN communication with the XMC1404 device using CAN node 1 RXD pin P4.8 and TXD pin P4.9.

If the user wants to test the CAN BSL mode of XMC1404 device using this CAN transceiver circuit, then R104 and R106 need to be removed, then RXD and TXD pins of IFX1051LE need to be connected to P0.14 and P0.15 of XMC1404 device respectively. Furthermore, dip-switches SWD/SPD and SWCLK need to set to position 'off'.

IFX1051LE requires 5V power supply. If the input voltage to XMC1404 is set to 3.3V, then remove R101 and solder R102. Next, supply an external power supply of 5V to pin4 (+) of JP102. By making these changes, the user can use this CAN transceiver for CAN BSL handshaking.



**Figure 7 CAN transceiver circuitry**



**Figure 8 CAN header JP102, H refers to CANH, L refers to CANL, + refers to VCC, 0 refers to GND**

## 2.6 Debug Interface and virtual com port

XMC1400 Boot Kit has on-board debugger which supports Serial Wire Debug (SWD) and Single Pin Debug (SPD) as debug interface. SPD is a proprietary debugging protocol from Infineon Technologies and it requires only 1 pin for debug communication. The debugger also provides a virtual COM port which support UART communication via P1.3 (rx-in) and P1.2 (tx-out) of XMC1400. There is a 2x5 pins Header Debug connector X201.

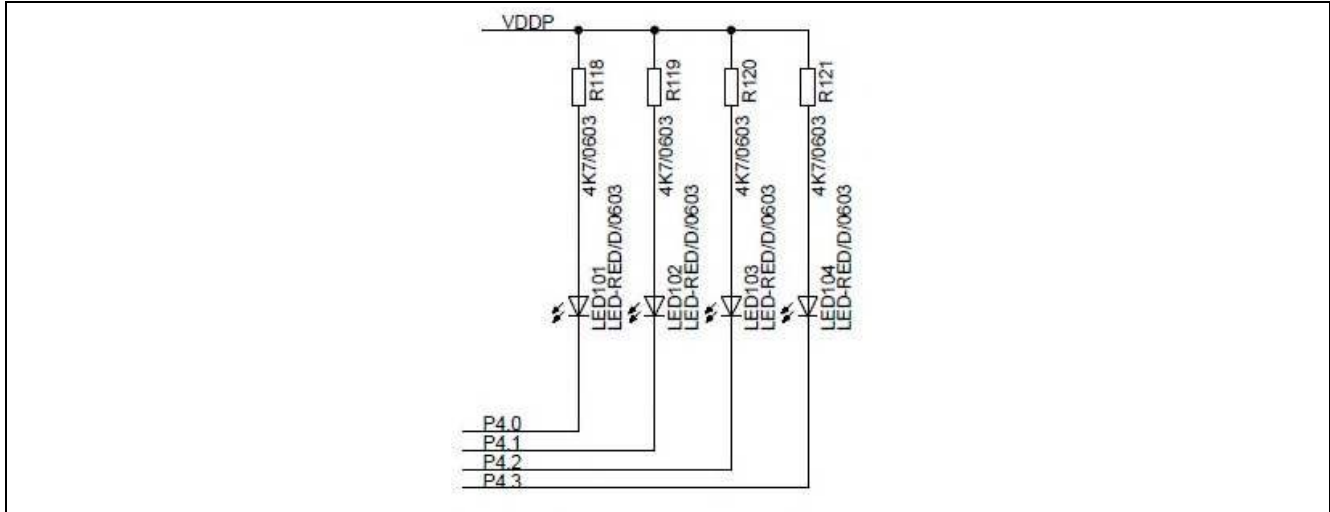
**Table 1 Debug connector X201**

Pin	Signal Name	XMC1400 Signal	Description
1	SWCLK	P0.15	SWD clock signal
2	SWD(SPD)	P0.14	SWD / SPD signal
3	VDDP	VDDP	+5V
4	GND	VSSP	Ground
5	GND	VSSP	Ground
6	VDDP	VDDP	+5V
7	PC_TXD	P1.3	UART data received
8	PC_RXD	P1.2	UART data transmit



## 2.7 LED

The port pins P4.0, P4.1, P4.2 and P4.3 are connected to LED101, LED102, LED103 and LED104 respectively. The LEDs turn on by output 'Low' at the respective port pins.



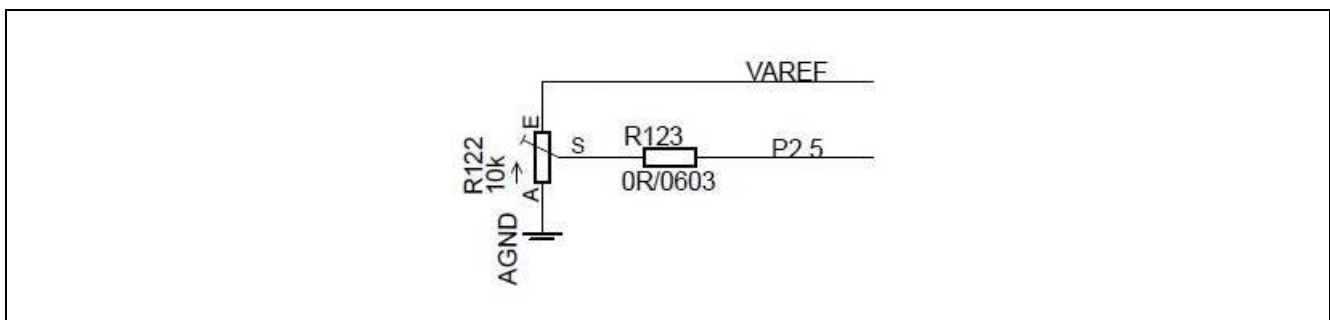
**Figure 9 LEDs circuit**

**Table 2 LEDs Pinout**

LED	XMC1400 Port Pin	Description
LED101	P4.0	Output 'Low' to on LED
LED102	P4.1	Output 'Low' to on LED
LED103	P4.2	Output 'Low' to on LED
LED104	P4.3	Output 'Low' to on LED

## 2.8 Potentiometer

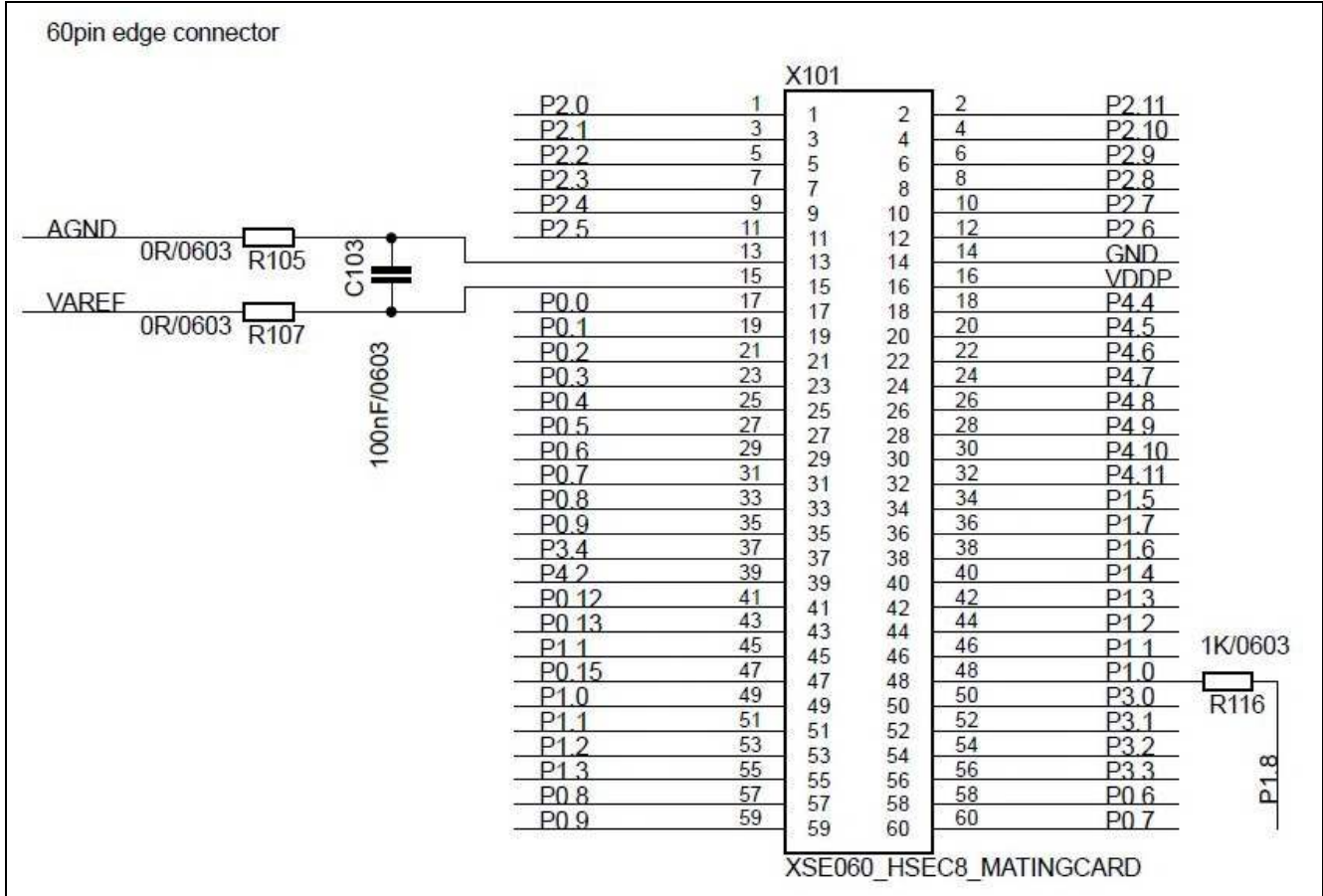
XMC1400 Boot Kit provides a potentiometer R110 for ease of use and testing of the on-chip analog to digital converter. The potentiometer is connected to the analog input P2.5. The analog output range of the potentiometer is the same as the VDDP voltage supplied to the XMC1404 device.



**Figure 10 Potentiometer Circuit**

## 2.9 Application Card connector

XMC1400 Boot Kit has a 2x30 pins card edge connector. The mating connector is SAMTEC HSEC8-130-01-L-RA-XX.



**Figure 11 Pinout of the 2x30 pin edge connector**

## **3 Production Data**

### **3.1 Schematics**

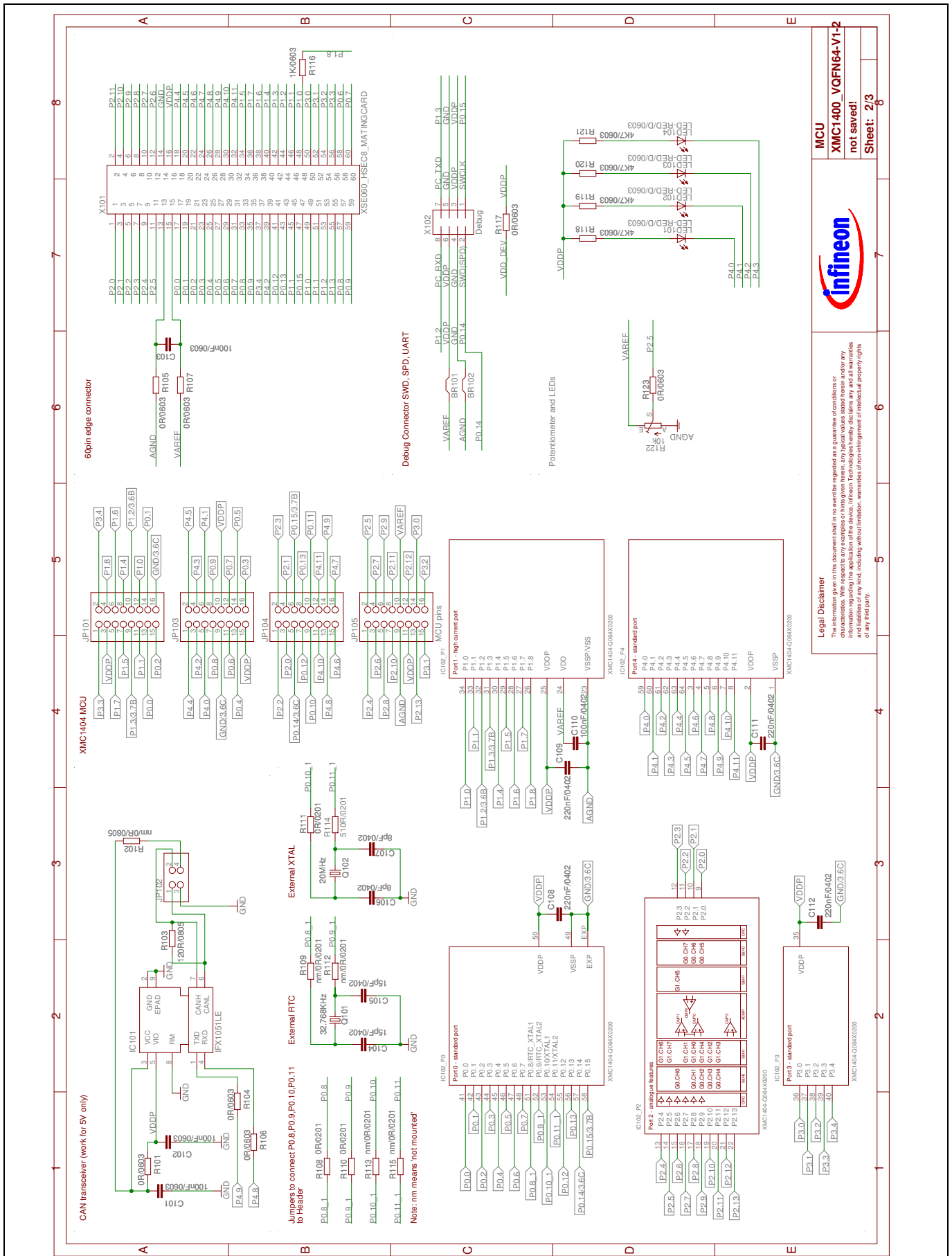
This chapter contains the schematics for the XMC1400 Boot Kit:

- Figure 12: CPU, Pin Headers, external crystals, CAN transceiver circuitry, Potentiometer, LEDs and 60pin Edge connector
- Figure 13: On-board Debugger, Power Supply

# XMC1400 Boot Kit

## For XMC1000 Family

### Production Data



MCU  
XMC1400\_VQFN64-V1-2  
not saved!  
Sheet: 2/3

**infineon**

**Legal Disclaimer**  
The information given in this document shall in no event be regarded as a guarantee of conditions or characteristics. With respect to any examples or hints given herein, any typical values stated therein and/or any reference to any specific device, the information does not constitute an offer of any product and is not intended to be used for any purpose other than that of a general reference. The information is provided for informational purposes only and is not intended to be used for any purpose other than that of a general reference. The information is provided for informational purposes only and is not intended to be used for any purpose other than that of a general reference.

Figure 12 Schematic 1 of 2 XMC1400 Boot Kit

# XMC1400 Boot Kit

## For XMC1000 Family

### Production Data

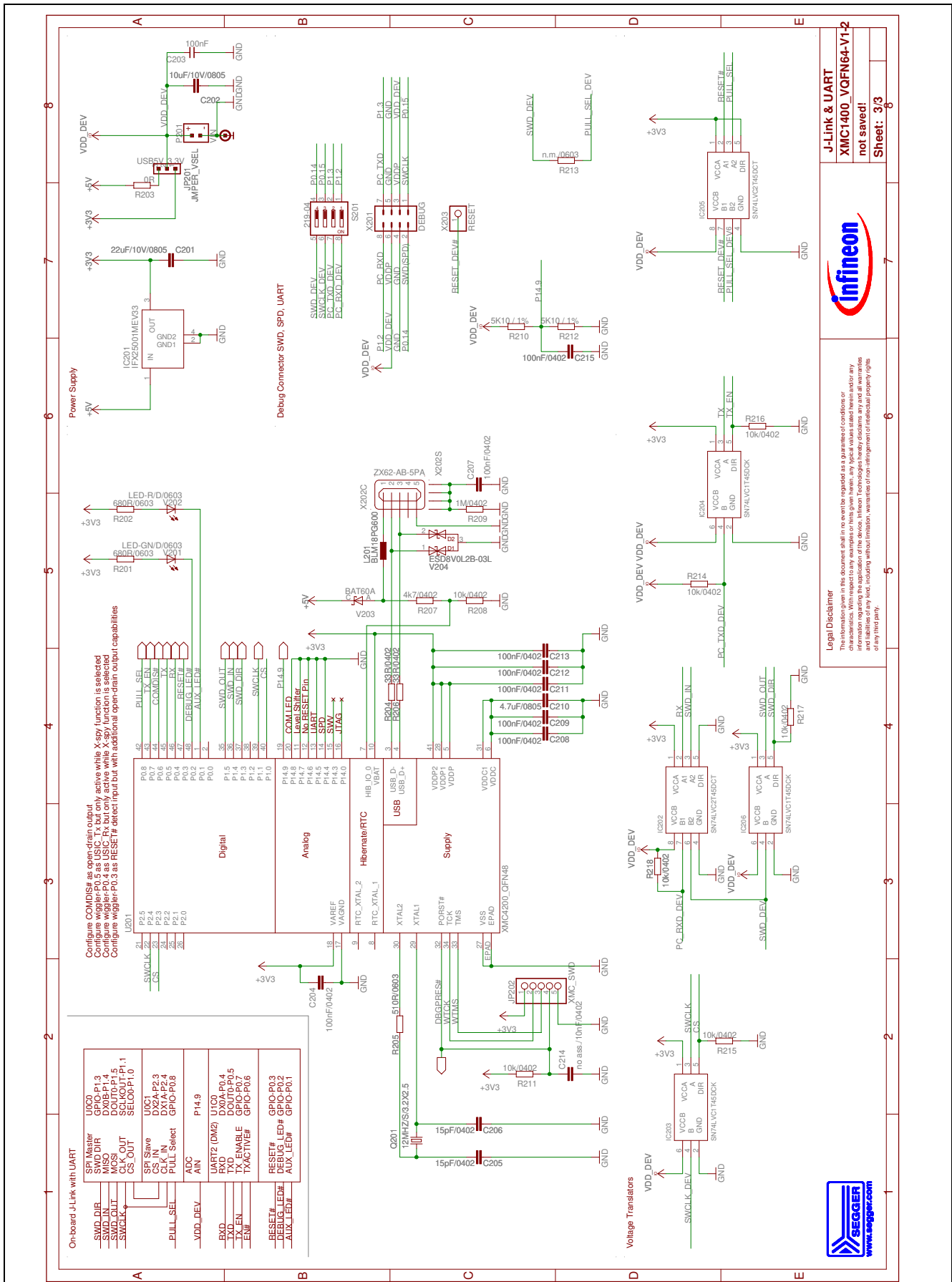


Figure 13 Schematic 2 of 2 XMC1400 Boot Kit

### 3.2 Layout and Geometry

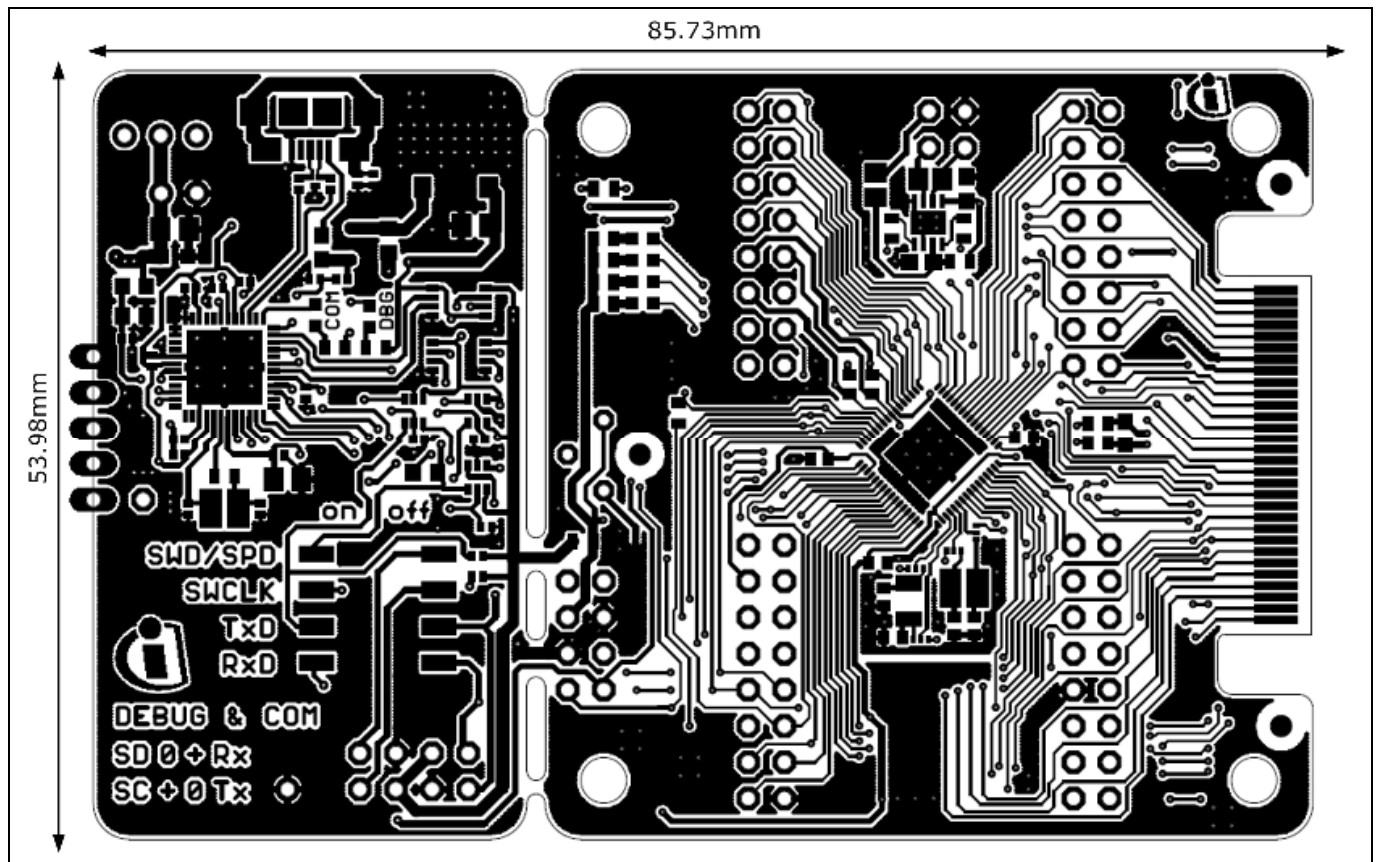
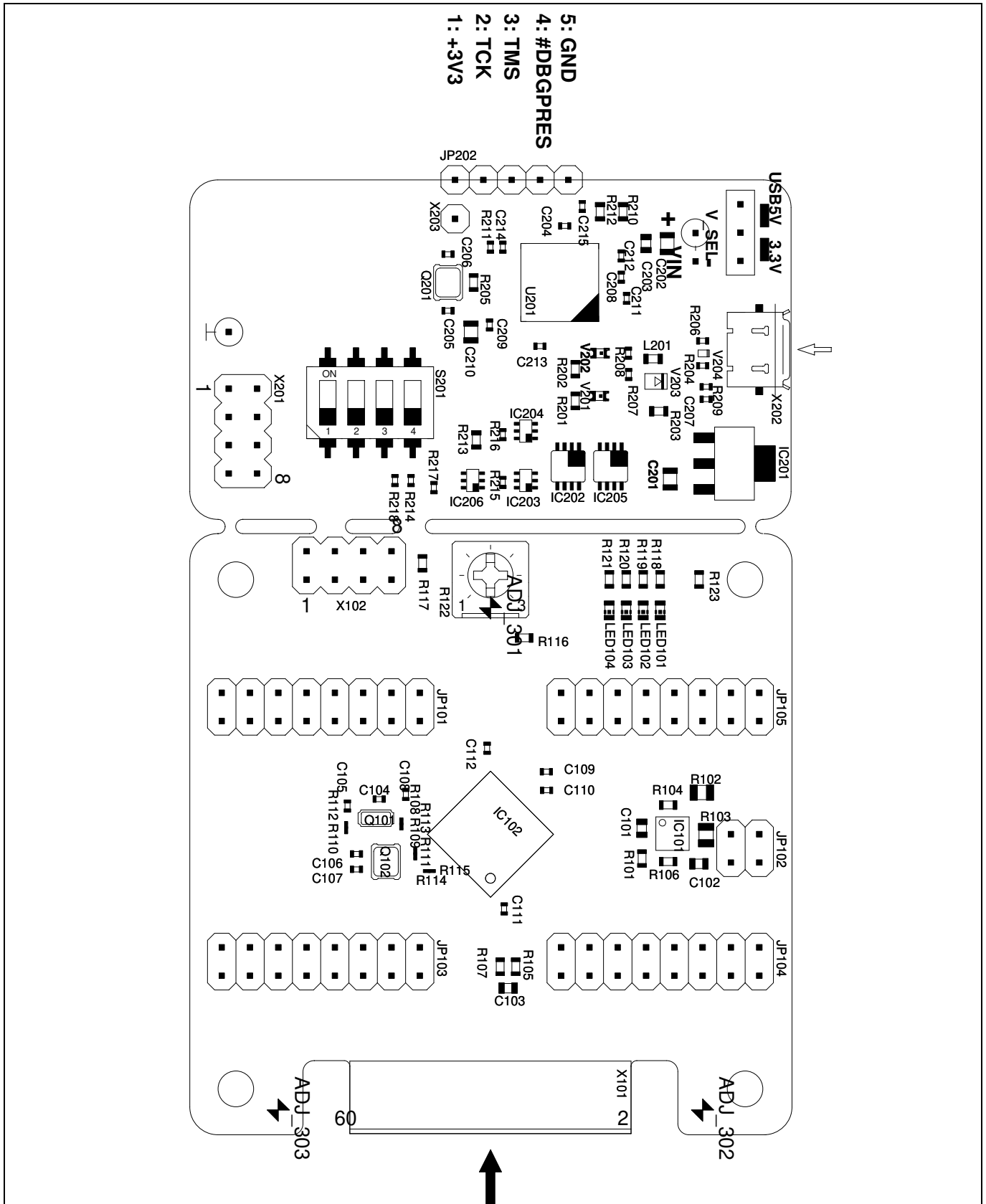


Figure 14 XMC1400 Boot Kit layout and geometry



### 3.3 CR number of XMC1400 Boot Kit



**Figure 15 CR number of XMC1400 Boot Kit**

**Production Data**

**3.4 Bill of Material**

**Table 3 XMC1400 Boot Kit**

No.	Value	Device	Qty	Reference Designator
1	JMPER_VSEL	1x3 pin header	1	JP201
2	CAN pins	2x2 pin header	1	JP102
3	Debug	2x4 pin header	2	X102 X201
4	100nF 10V 10% 0402	Capacitor X7R	9	C110 C204 C207 C208 C209 C211 C212 C213 C215
5	100nF 10V 10% 0603	Capacitor X7R	4	C101 C102 C103 C203
6	10uF 10V 10% 0805	Capacitor X7R	1	C202
7	15pF 10V 1% 0402	Capacitor NPO	4	C104 C105 C205 C206
8	220nF 10V 10% 0402	Capacitor X7R	4	C108 C109 C111 C112
9	22uF 10V 10% 0805	Capacitor X7R	1	C201
10	4.7uF 10V 10% 0805	Capacitor X7R	1	C210
11	8pF 10V 2% 0402	Capacitor NPO	2	C106 C107
12	12 MHz S 3.2X2.5	Crystal 12 MHz SMD 8pF NX3225GB-12.000M-STD-CRA-2	1	Q201
13	20 MHz S 3.2X2.5	Crystal 20 MHz SMD 8pF NX3225GB-20.000M-STD-CRA-2	1	Q102
13a <sup>1)</sup>	20 MHz S 3.2X2.5	Crystal 20 MHz SMD 8pF HONG KONG X'TALS LIMITED 3225M2000IB01	1	Q102
14	ESD8V0L2B-03L	Diode, Infineon	1	V204
15	SN74LVC2T45DCT	Dual-bit Dual supply bus transceiver	2	IC202 IC205
16	BLM18PG600	Ferrite Bead	1	L201
17	LED-GN D 0603	LED, green	1	V201
18	jumper (red)	Jumper	1	JP201A
19	ZX62-AB-5PA	Connector Micro-USB AB SMD ZX62-AB-5PA Hirose	1	X202
20	LED-RED D 0603	LED, red	1	V202
21	LED-RED D 0603	LED, red	4	LED101 LED102 LED103 LED104
22	0R 10% 0201	Resistor	3	R108 R110 R111
23	0R 10% 0603	Resistor	8	R101 R104 R105 R106 R107 R117 R123 R203
24	10k	Resistor, Potentiometer	1	R122
25	10k 10% 0402	Resistor	7	R208 R211 R214 R215 R216 R217 R218
26	120R 10% 0805	Resistor	1	R103
27	1K 10% 0603	Resistor	1	R116
28	1M 10% 0402	Resistor	1	R209

# XMC1400 Boot Kit

## For XMC1000 Family



### Production Data

No.	Value	Device	Qty	Reference Designator
29	33R 10% 0402	Resistor	2	R204 R206
30	4k710% 0402	Resistor	1	R207
31	4K7 10% 0603	Resistor	4	R118 R119 R120 R121
32	510R 10% 0201	Resistor	1	R114
33	510R 10% 0603	Resistor	1	R205
34	5K10 10% 1%	Resistor	2	R210 R212
35	680R 10% 0603	Resistor	2	R201 R202
36	32.768 kHz, FC-135	Crystal 32.768 kHz SMD 12.5pF NDK NX3215SA-32.678K	1	Q101
36a <sup>1)</sup>	32.768 kHz, FC-135	Crystal 32.768 kHz SMD HONG KONG X'TALS LIMITED 3215K3276IB01	1	Q101
37	SN74LVC1T45DCK	Single bit Dual supply bus transceiver	3	IC203 IC204 IC206
38	IFX1051LE	CAN transceiver, Infineon	1	IC101
39	XMC1404-Q064X0200	Microcontroller, Infineon	1	IC102
40	IFX25001MEV33	Voltage regulator, 3V3, Infineon	1	IC201
41	XMC4200-Q48K256	Microcontroller, Infineon	1	U201
42	BAT60A	Diode Infineon	1	V203
43	no ass. 10nF 10% 0402	Capacitor	1	C214
44	MCU pins	2x8 pin header	4	JP101 JP103 JP104 JP105
45	XMC_SWD	1x5 pin header	1	1X05
46	no ass. 0R 10% 0805	Resistor	1	R102
47	no ass. 0R 10% 0201	Resistor	1	R109
48	no ass. 0R 10% 0201	Resistor	1	R112
49	no ass. 0R 10% 0201	Resistor	1	R113
50	no ass. 0R10% 0201	Resistor	1	R115
51	no ass. 0R 10% 0603	Resistor	1	R213

Note: 1) Alternative part.

## Revision History

### Major changes since the last revision

Page or Reference	Description of change
V1.0	Initial Version

#### Trademarks of Infineon Technologies AG

AURIX™, C166™, CanPAK™, CIPOS™, CoolGaN™, CoolMOS™, CoolSET™, CoolSiC™, CORECONTROL™, CROSSAVE™, DAVE™, DI-POL™, DrBlade™, EasyPIM™, EconoBRIDGE™, EconoDUAL™, EconoPACK™, EconoPIM™, EiceDRIVER™, eupec™, FCOS™, HITFET™, HybridPACK™, Infineon™, ISOFACE™, IsoPACK™, i-Wafer™, MIPAQ™, ModSTACK™, my-d™, NovalithIC™, OmniTune™, OPTIGA™, OptiMOS™, ORIGA™, POWERCODE™, PRIMARION™, PrimePACK™, PrimeSTACK™, PROFET™, PRO-SIL™, RASIC™, REAL3™, ReverSave™, SatRIC™, SIEGET™, SIPMOS™, SmartLEWIS™, SOLID FLASH™, SPOC™, TEMPFET™, thinQ!™, TRENCHSTOP™, TriCore™.

Trademarks updated August 2015

#### Other Trademarks

All referenced product or service names and trademarks are the property of their respective owners.

**Edition 2016-01-21**

**Published by**

**Infineon Technologies AG**

**81726 Munich, Germany**

**© 2016 Infineon Technologies AG.**

**All Rights Reserved.**

**Do you have a question about this document?**

**Email: [erratum@infineon.com](mailto:erratum@infineon.com)**

**Document reference**

**UG\_201512\_PL30\_005**

#### IMPORTANT NOTICE

The information contained in this application note is given as a hint for the implementation of the product only and shall in no event be regarded as a description or warranty of a certain functionality, condition or quality of the product. Before implementation of the product, the recipient of this application note must verify any function and other technical information given herein in the real application. Infineon Technologies hereby disclaims any and all warranties and liabilities of any kind (including without limitation warranties of non-infringement of intellectual property rights of any third party) with respect to any and all information given in this application note.

The data contained in this document is exclusively intended for technically trained staff. It is the responsibility of customer's technical departments to evaluate the suitability of the product for the intended application and the completeness of the product information given in this document with respect to such application.

For further information on the product, technology, delivery terms and conditions and prices please contact your nearest Infineon Technologies office ([www.infineon.com](http://www.infineon.com)).

#### WARNINGS

Due to technical requirements products may contain dangerous substances. For information on the types in question please contact your nearest Infineon Technologies office.

Except as otherwise explicitly approved by Infineon Technologies in a written document signed by authorized representatives of Infineon Technologies, Infineon Technologies' products may not be used in any applications where a failure of the product or any consequences of the use thereof can reasonably be expected to result in personal injury.