



soberton inc.

# SP DYNAMIC SPEAKER UNIT

Acoustic Product Specification

Product Number: SP-1511L



Release | Revision: C/2018

## CONTENTS

This document contains the technical specifications for the dynamic speaker unit.

**Page 1**  
Speaker Electroacoustic Characteristics

General Specifications

**Page 2**  
Reliability Tests

**Page 3**  
Measuring Method (Speaker Mode)

Standard Test Condition of Speakers

**Page 4**  
Frequency Response Curve

**Page 5**  
Dimensions

**Page 6**  
Packing

## Speaker Electroacoustic Characteristics

### Sound Pressure Level

83±3dB SPL @1.0, 1.2, 1.5 and 2.0KHz in average (0dB SPL=20µPa)  
Measuring condition: 0.1W (Sine wave) 10cm measured with baffle shown in Fig.1.

### Frequency Response Curve

As shown in Figure 2

### Response Frequency

600±20%Hz @ 1V in free air

850±20%Hz @ 1V in 1cc box

### Input Power (Nominal and Maximum)

Rated Noise Power: 0.7W (in 1cc box)

Short Term Maximum Power: 1.0W (in 1cc box)

### Operation Test

Must be free of audible noise (buzzes and rattles)

(300~5KHz frequency range, input level up to 2.36Vrms in 1cc box)

### Distortion

Less than 10% @1KHz,0.1M,0.1W frequency range, input level up to 0.1W

## General Specifications

### Operating Temperature Range

-20°C~+60°C

### Storage Temperature Range

-30°C~+70°C

### Standard Test Conditions

Temperature 17°C~25°C

Relative Humidity 45%~80%(RH)

### Impedance

8±15%Ω (@2KHz 1V) without baffle

### Dimension

15.0 x 11.0 wire (100mm)

### IP Level

No rating



soberton inc.

## SP DYNAMIC SPEAKER UNIT

Acoustic Product Specification

Product Number: SP-1511L



Release | Revision: C/2018

### CONTENTS

This document contains the technical specifications for the dynamic speaker unit.

#### Page 1

Speaker Electroacoustic Characteristics

General Specifications

#### Page 2

Reliability Tests

#### Page 3

Measuring Method (Speaker Mode)

Standard Test Condition of Speakers

#### Page 4

Frequency Response Curve

#### Page 5

Dimensions

#### Page 6

Packing

## Reliability Tests

The sound pressure as specified will neither deviate more than  $\pm 3\text{dB}$  from the initial value, nor have any significant damage after any of following testing.

### High Temperature Test

High Temperature  $+60\pm 2^\circ\text{C}$

Duration 96 hours

### Low Temperature Test

Low Temperature  $-20\pm 2^\circ\text{C}$

Duration 96 hours

### Heat Shock Test

High Temperature  $+60\pm 2^\circ\text{C}$

Low Temperature  $-20\pm 2^\circ\text{C}$

Changeover Time  $< 30$  seconds

Duration 1 hour

Cycle 100

### Humidity Test

Temperature  $+ 40\pm 2^\circ\text{C}$

Relative Humidity 90%~95%

Duration 96 hours

### Temperature Cycle Test

Temperature  $-20^\circ\text{C}$   $+60^\circ\text{C}$

Duration 45 minutes 45 minutes

Temperature gradient  $1\sim 3^\circ\text{C}/\text{min}$

Cycle 25

### Drop Test

Mounted with dummy set mass 100 g

Height 1.5 m

Cycle 6 (1 each plain) onto the concrete board

### Load Test

Speaker mode White noise (EIA filter) for 96 hours@0.7W input power.



soberton inc.

# SP DYNAMIC SPEAKER UNIT

Acoustic Product Specification

Product Number: SP-1511L



Release | Revision: C/2018

## CONTENTS

This document contains the technical specifications for the dynamic speaker unit.

**Page 1**  
Speaker Electroacoustic Characteristics

General Specifications

**Page 2**  
Reliability Tests

**Page 3**  
Measuring Method (Speaker Mode)

Standard Test Condition of Speakers

**Page 4**  
Frequency Response Curve

**Page 5**  
Dimensions

**Page 6**  
Packing

## Measuring Method (Speaker Mode)

### Test Condition Standard

Temperature 15 ~ 35°C

Relative humidity 45% ~ 85%

Atmospheric pressure 860mbar to 1060mbar

### Standard Test Fixture

Input Power 0.1W

Zero Level -dB

Mode TSR

Potentiometer Range 50dB

Sweep Time 0.5sec

## Standard Test Condition of Speaker (Fig. 1)

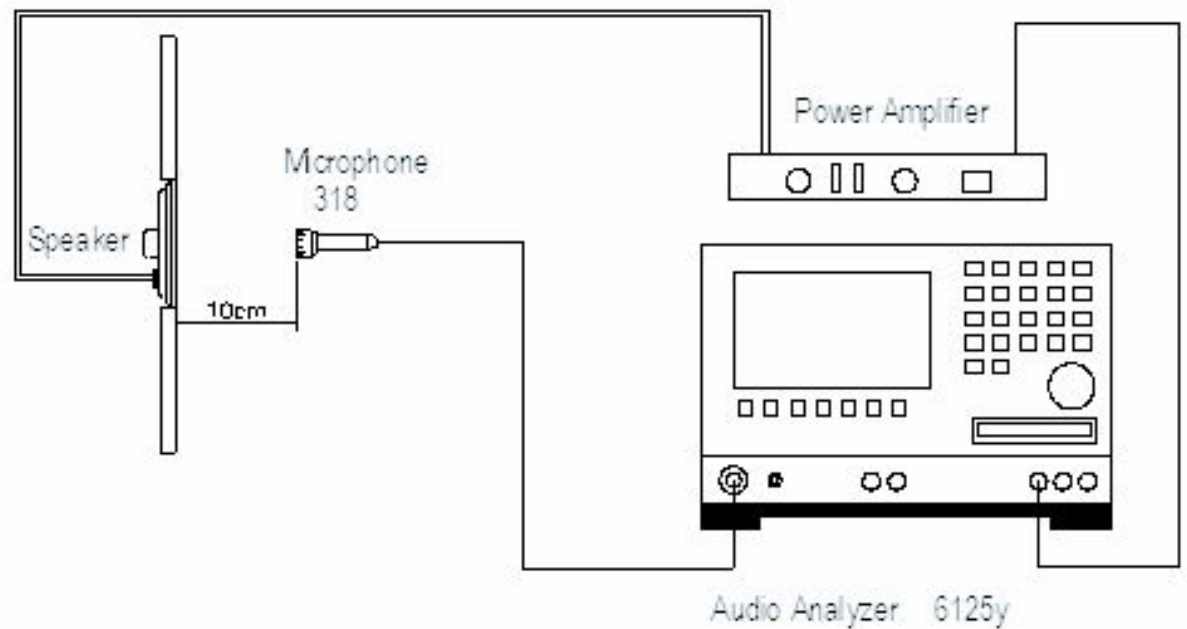



soberton inc.

## SP DYNAMIC SPEAKER UNIT

Acoustic Product Specification

Product Number: SP-1511L



Release | Revision: C/2018

### CONTENTS

This document contains the technical specifications for the dynamic speaker unit.

#### Page 1

Speaker Electroacoustic Characteristics

General Specifications

#### Page 2

Reliability Tests

#### Page 3

Measuring Method (Speaker Mode)

Standard Test Condition of Speakers

#### Page 4

Frequency Response Curve

#### Page 5

Dimensions

#### Page 6

Packing

### Frequency Response Curve (Fig. 2)

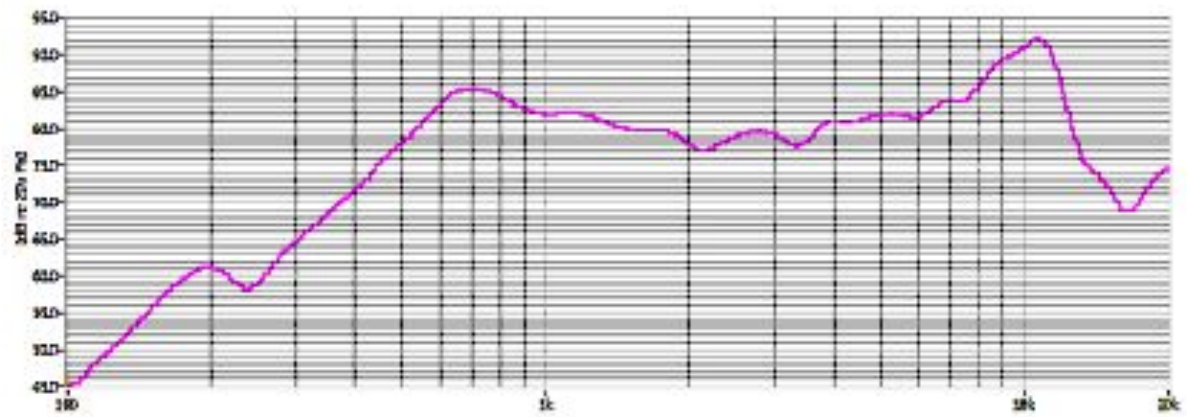



soberton inc.

# SP DYNAMIC SPEAKER UNIT

Acoustic Product Specification

Product Number: SP-1511L



Release | Revision: C/2018

## CONTENTS

This document contains the technical specifications for the dynamic speaker unit.

**Page 1**  
Speaker Electroacoustic Characteristics

General Specifications

**Page 2**  
Reliability Tests

**Page 3**  
Measuring Method (Speaker Mode)

Standard Test Condition of Speakers

**Page 4**  
Frequency Response Curve

**Page 5**  
Dimensions

**Page 6**  
Packing

## Dimensions

Tolerance:  $\pm 0.5$  (unit: mm)

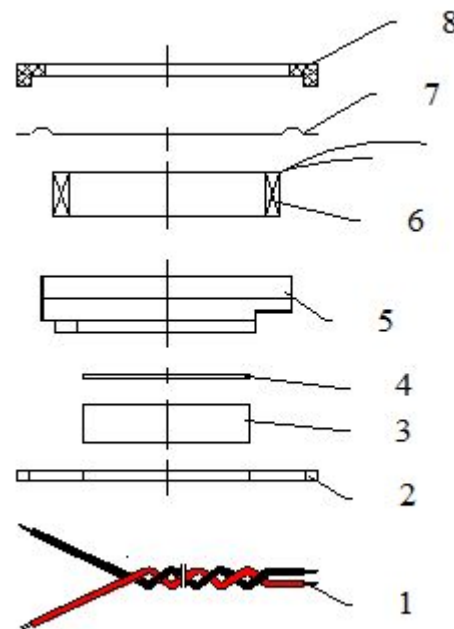
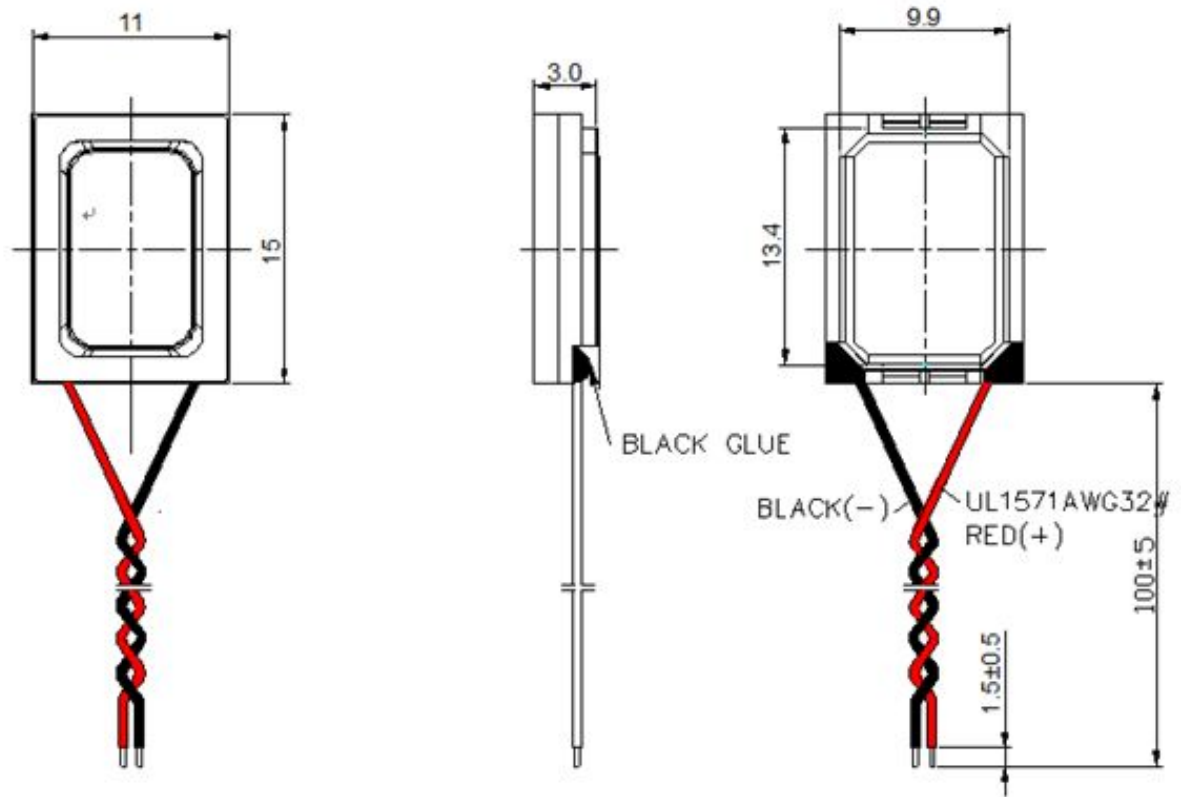

No.	Part Name	Material	Quantity
1	Wire	UL1571 / AWG32#	1
2	U Yoke	SPCC	1
3	Magnet	Nd Fe B	1
4	Plate 3	SPCC	1
5	Frame	Black PPA	1
6	Voice Coil	Copper wire	1
7	Diaphragm	PEEK	1
8	Cap	Black PPA	1



soberton inc.

# SP DYNAMIC SPEAKER UNIT

Acoustic Product Specification

Product Number: SP-1511L



Release | Revision: C/2018

## CONTENTS

This document contains the technical specifications for the dynamic speaker unit.

### Page 1

Speaker Electroacoustic Characteristics

General Specifications

### Page 2

Reliability Tests

### Page 3

Measuring Method (Speaker Mode)

Standard Test Condition of Speakers

### Page 4

Frequency Response Curve

### Page 5

Dimensions

### Page 6

Packing

## Packing

