

SHARP

SYSTEM DEVICE DIVISION I
ELECTRONIC COMPONENTS AND DEVICES GROUP
SHARP CORPORATION

SPECIFICATION

DEVICE SPECIFICATION FOR

SOLID STATE RELAY

MODEL No.

R33MF5

(Business dealing name : PR33MF51YPLF)

Specified for _____

Enclosed please find copies of the Specifications which consists of 15 pages including cover.
This specification sheets and attached sheets shall be both side copy.
After confirmation of the contents, please be sure to send back copies of the Specifications
with approving signature on each.

CUSTOMER'S APPROVAL

DATE _____

BY _____

PRESENTED

DATE Apr. 8, 2011

BY T. Ichinose

T. Ichinose,
Department General Manager of
Development Department IV
System Device Division I
Electronic Components and Devices Group
SHARP CORPORATION

Product name : SOLID STATE RELAY

Model No. : R33MF5

(Business dealing name : PR33MF51YPLF)

1. These specification sheets include materials protected under copyright of Sharp Corporation ("Sharp"). Please do not reproduce or cause anyone to reproduce them without Sharp's consent.
2. When using this product, please observe the absolute maximum ratings and the instructions for use outlined in these specification sheets, as well as the precautions mentioned below. Sharp assumes no responsibility for any damage resulting from use of the product which does not comply with the absolute maximum ratings and the instructions included in these specification sheets, and the precautions mentioned below.

(Precautions)

- (1) Please do verify the validity of this part after assembling it in customer's products, when customer wants to make catalogue and instruction manual based on the specification sheet of this part.

- (2) This product is designed for use in the following application areas ;

<ul style="list-style-type: none"> · OA equipment Audio visual equipment · Home appliances · Telecommunication equipment (Terminal) · Measuring equipment · Tooling machines · Computers

If the use of the product in the above application areas is for equipment listed in paragraphs (3) or (4), please be sure to observe the precautions given in those respective paragraphs.

- (3) Appropriate measures, such as fail-safe design and redundant design considering the safety design of the overall system and equipment, should be taken to ensure reliability and safety when this product is used for equipment which demands high reliability and safety in function and precision, such as ;

<ul style="list-style-type: none"> · Transportation control and safety equipment (aircraft, train, automobile etc.) · Traffic signals · Gas leakage sensor breakers · Rescue and security equipment · Other safety equipment

- (4) Please do not use this product for equipment which require extremely high reliability and safety in function and precision, such as ;

<ul style="list-style-type: none"> · Space equipment · Telecommunication equipment (for trunk lines) · Nuclear power control equipment · Medical equipment · Power generation and power transmission control system (Key system)

- (5) Please contact and consult with a Sharp sales representative if there are any questions regarding interpretation of the above four paragraphs.

3. Please contact and consult with a Sharp sales representative for any questions about this product.

1. Application

This specification applies to the outline and characteristics of Solid State Relay (SSR),
Model No. R33MF5 [Apply line voltage 200V AC(sine wave)].

2. Outline

Refer to the attached sheet, page 7.

3. Ratings and characteristics

Refer to the attached sheet, page 8 to 9

4. Reliability

Refer to the attached sheet, page 10.

5. Outgoing inspection

Refer to the attached sheet, page 11.

6. Supplement

6.1 Business dealing name

The business dealing name used for this product when ordered or delivered shall be PR33MF51YPLF.

6.2 Package specification

Refer to the attached sheet, page 12 to 14.

6.3 Isolation voltage shall be measured in the following method.

- (1) Short between anode and cathode on the primary side and between anode, cathode and gate on the secondary side.
- (2) The dielectric withstanding tester with zero-cross circuit shall be used.
- (3) The wave form of applied voltage shall be a sine wave.

(It is recommended that the isolation voltage be measured in insulation oil.)

6.4 This Model is approved by UL and CSA.

Approved Model No. : R33MF5

1. UL file No. : E94758
2. CSA file No. : LR63705

CSA approved mark "  " and rating shall be indicated on minimum unit package.

6.5. The relevant models are the models Approved by VDE according to DIN EN 60747-5-2

VDE approved No. : 40008898

Approved Model No. : R33MF5

- Operating isolation voltage $U_{IORM(Peak)}$: 890V
- Transient voltage $(Peak)$: 7100V
- Pollution : 2
- Clearances distance (Between input and output) : 6.4mm (MIN.)
- Creepage distance (Between input and output) : 6.4mm (MIN.)
- Isolation thickness between input and output : 0.15mm (MIN.)
- Tracking-proof : CTI 175
- Safety limit values

Current (I _{si}) :	200mA (Diode side)
Power (P _{si}) :	900mW (Triac side)
Temperature (T _{si}) :	150°C

In order to keep safety electric isolation of photocoupler, please set the protective circuit to keep within safety limit values when the actual application equipment troubled.

- Indication of VDE approval "  " is printed on minimum unit package.

Isolation specification according to EN 60747-5-2

Parameter	Symbol	Condition	Rating	Unit	Remark
Class of environmental test	-	-	30/100/21	-	
Pollution	-	-	2	-	
Maximum operating isolation voltage	$U_{IORM(PEAK)}$	-	890	V	Refer to the Diagram 1, 2 (Page 6)
Partial discharge test voltage (Between input and output)					
Diagram 1	$U_{pr(PEAK)}$	$t_p=10s, q_c<5pC$	1340	V	
Diagram 2		$t_p=1s, q_c<5pC$	1670	V	
Maximum over-voltage	$U_{IOTM(PEAK)}$	$t_{NI}=60s$	7100	V	
Safety maximum ratings					Refer to the Fig. 1, 2 (Page 6)
1) Case temperature	T_{si}	$I_F=0, P_C=0$	150	°C	
2) Input current	I_{si}	$P_C=0$	200	mA	
3) Electric power (Output or Total power dissipation)	P_{si}	-	900	mW	
Isolation resistance (Test voltage between input and output ; DC500V)	R_{ISO}	$T_a=T_{si}$	MIN. 10^9	Ω	
		$T_a=T_{opr(MAX)}$	MIN. 10^{11}		
		$T_a=25^\circ C$	MIN. 10^{12}		

Precautions in performing isolation test

(1) Partial discharge test methods shall be the ones according to the specifications of EN 60747-5-2.

(2) Please don't carry out isolation test (Viso) over U_{IOTM} .

This product deteriorates isolation characteristics by partial discharge due to applying high voltage (ex. U_{IOTM}).

And there is possibility that partial discharge occurs in operating isolation voltage (U_{IORM}).

6.6 This product is not designed against irradiation.

This product is assembled with electrical input and output.

This product incorporates non-coherent light emitting diode.

6.7 ODS materials

This product shall not contain the following materials.

Also, the following materials shall not be used in the production process for this product.

Materials for ODS : CFCs, Halon, Carbon tetrachloride, 1.1.1-Trichloroethane (Methyl chloroform)

6.8 Brominated flame retardants

Specified brominated flame retardants (PBB and PBDE) are not used in this device at all.

6.9 Compliance with each regulation

6.9.1 The RoHS directive(2002/95/EC)

This product complies with the RoHS directive(2002/95/EC) .

Object substances: mercury, lead (except for lead in high melting temperature type solders ^{*1} and glass of electronic components), cadmium, hexavalent chromium, polybrominated biphenyls (PBB) and polybrominated diphenyl ethers (PBDE)

*1 : i.e. tin-lead solder alloys containing more than 85% lead

6.9.2 Content of six substances specified in Management Methods for Control of Pollution Caused by Electronic Information Products Regulation (Chinese : 电子信息产品污染控制管理办法).

Category	Toxic and hazardous substances					
	Lead (Pb)	Mercury (Hg)	Cadmium (Cd)	Hexavalent chromium (Cr ⁶⁺)	Polybrominated biphenyls (PBB)	Polybrominated diphenyl ethers (PBDE)
Solid State Relay	*	✓	✓	✓	✓	✓

✓ : indicates that the content of the toxic and hazardous substance in all the homogeneous materials of the part is below the concentration limit requirement as described in SJ/T 11363-2006 standard .

* : indicates that the content of the toxic and hazardous substance in at least one homogeneous material of the part exceeds the concentration limit requirement as described in SJ/T 11363-2006 standard.

Lead in high melting temperature type solders (i.e. tin-lead solder alloys containing more than 85% lead) and glass of electronic components (designated by “*” in the above table) are exempt from the RoHS directive (2002/95/EC) , because there is no effective way to eliminate or substitute them by present scientific technology.

7. Notes

7.1 Circuit designing

(1) Trigger current

The LED used in the Solid state relay generally decreases the light emission power by operation. In case of long operation time, please decide I_F value so that I_F is twice or more of the Maximum value of the Minimum triggering current at circuit design with considering the decreases of the light emission power of the LED. (50%/5years)

(2) Snubber circuit

This device doesn't have built-in snubber circuit.

To avoid the false operation and protect SSR, please locate the appropriate snubber circuit between output pins base by the load. (Recommendable values : $R_s=47\Omega$, $C_s=0.022\mu F$)

Particularly, in case the device is used for the load such as solenoid valves and motors, false operation may happen in off-state due to rapid change of voltage at output pins caused by the phase difference of load current.

So please be sure to locate the snubber circuit ($R_s=47\Omega$, $C_s=0.022\mu F$) and make sure the device works properly in actual conditions.

In addition, the values of snubber circuit may have to be changed if necessary after tested in actual conditions.

(3) Off-state input current

Input current (I_F) at off-state shall be set 0.1mA or less.

(4) Pulse drive

In case that pulse drive is carried out, the pulse width of input signal should be 1ms or more.

(5) If the voltage exceeding the repetitive peak off-state voltage (V_{DRM}) in the absolute maximum ratings is applied to the phototriac, it may cause not only faulty operation but breakdown.

Make sure that the surge voltage exceeding V_{DRM} shall not be applied by using the varistor, CR.

7.2 Cleaning

(1) Solvent cleaning : Solvent temperature 45°C or less Immersion for 3 min or less

(2) Ultrasonic cleaning : The effect to device by ultrasonic cleaning differs by cleaning bath size, ultrasonic power output, cleaning time, PCB size or device mounting condition etc.
Please test it in actual using condition and confirm that any defect doesn't occur before starting the ultrasonic cleaning.

(3) Applicable solvent : Ethyl alcohol, Methyl alcohol, Isopropyl alcohol

In case the other solvent is used, there are cases that the packaging resin is eroded.

Please use the other solvent after thorough confirmation is performed in actual using condition.

7.3 Using method

As to this product, all pin shall be used by soldering on the print wiring board. (Socket and others shall not be used.)

7.4 Precautions for Soldering

(1) In case of solder reflow

It is recommended to be done at the temperature and the time within the temperature profile as shown in the figure below.(2 times or less)

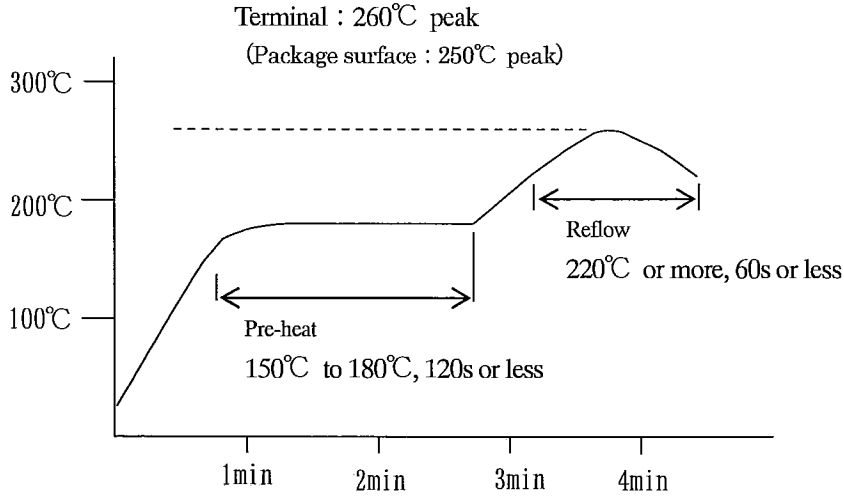

(2) In case of flow soldering (Avoid immersing the resin part in the solder.)

It is recommended that flow soldering be carried out at 270°C or less and within 10s
 (Pre-heating:100 to 150°C,30 to 80 s) : Within 2times

(3) In case of hand soldering

It is recommended that hand soldering be carried out at 400°C or less and within 3s.
 : Within 2 times

(4) Other Precaution

Depending on equipment and soldering conditions (temperature, Using solder etc.), the effect to junction between PCB and lead pins of photocoupler is different.
 Please confirm that there is no problem on the actual use conditions.

Method of Diagram 1: Breakdown test (Apply to type test and sampling test)

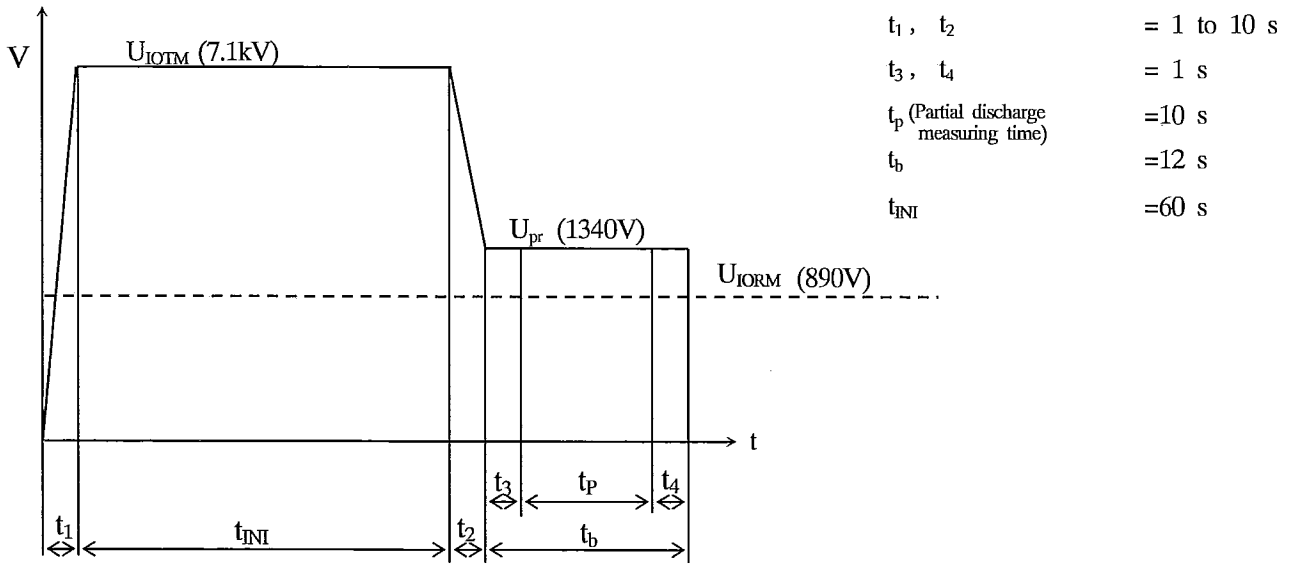

Method of Diagram 2: Non breakdown test (Apply to all device test)

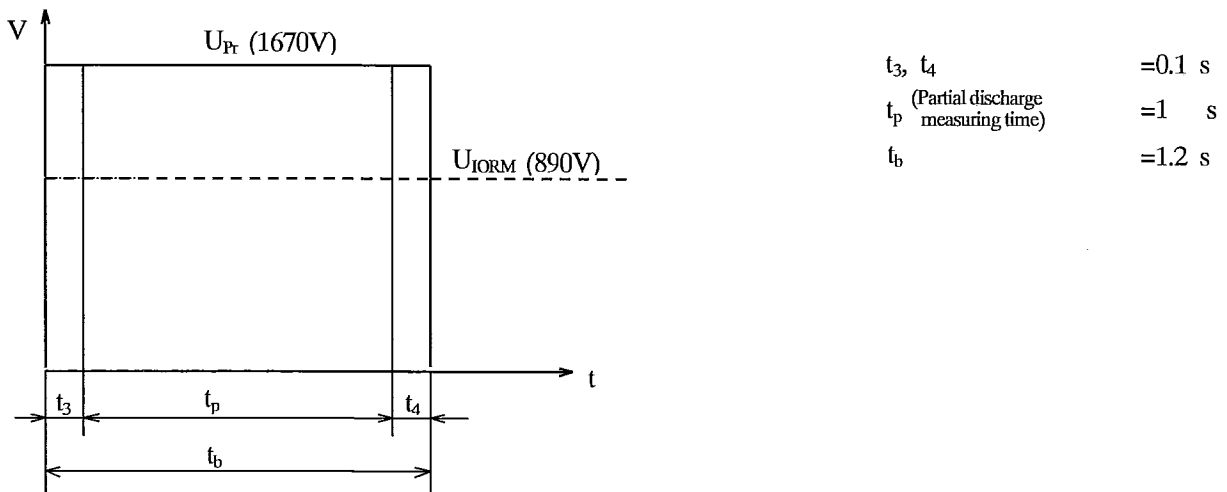

(Fig.1) Safety maximum power dissipation vs. ambient temperature (When failed)

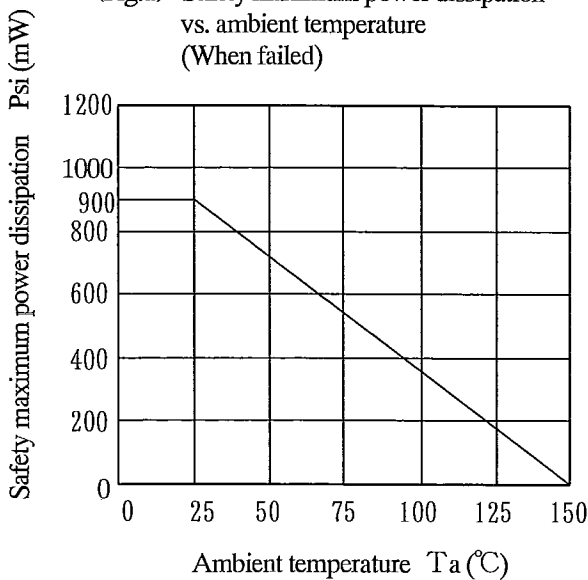

(Fig.2) Safety maximum forward current vs. ambient temperature (When failed)

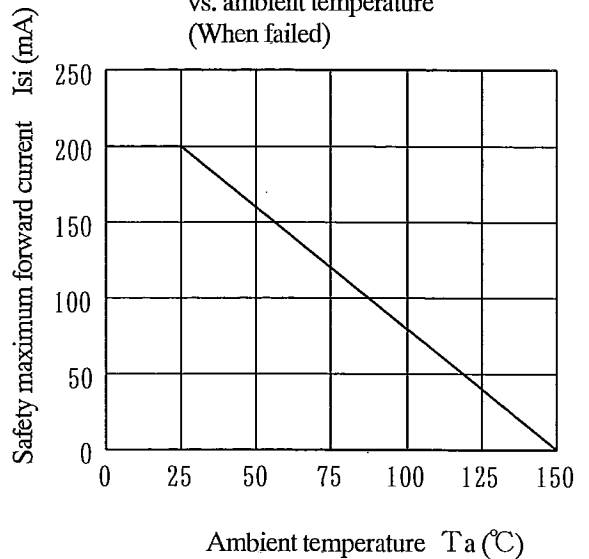

REFERENCE

PR33MF5 TYPE

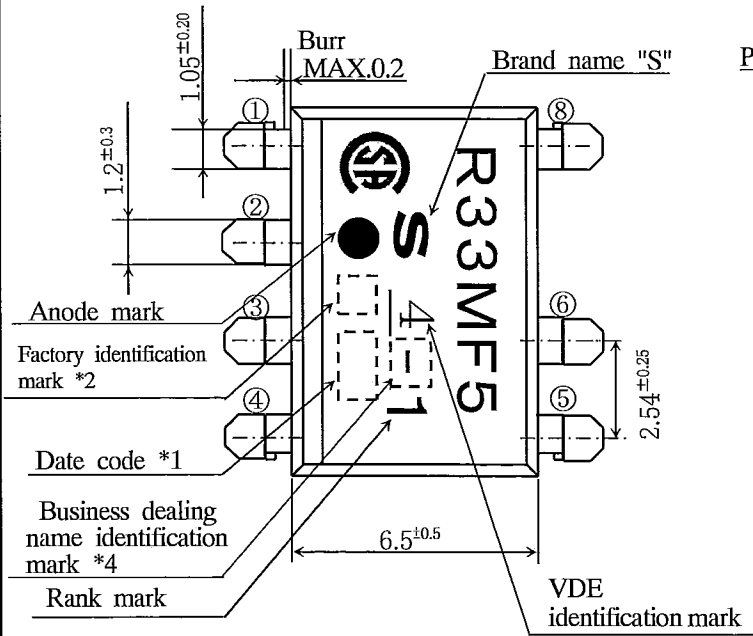

Pin-Number and internal connection diagram

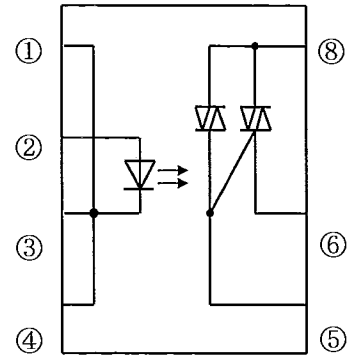

② : Anode ⑧ : T₂
 ①③④ : Cathode ⑥ : T₁
 ⑤ : Gate

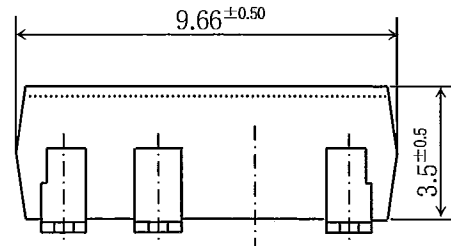
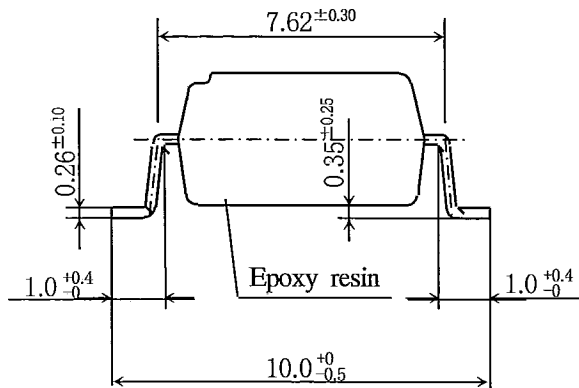

Marking is laser marking

*1) 2-digit number shall be marked according to OLD DIN standard.

*2) Factory identification mark applies to the below.

Without : SUN-S Corporation(Japan)

: SUN-S Electronic Technology (KUNSHAN) Co. Ltd (China)

*3) Pin material : Copper Alloy

Pin finish : SnCu plating (Cu : TYP. 2%)

*4) Business dealing name identification mark : —

Product mass : Approx. 0.54g

UNIT : 1/1 mm	
Name	R33MF5 Outline Dimensions (Business dealing name : PR33MF51YPLF)

3. Ratings and characteristics

3.1 Absolute maximum ratings

Ta=25°C

Parameter		Symbol	Rating	Unit
Input	Forward current *1	I _F	50	mA
	Reverse voltage	V _R	6	V
Output	RMS on-state current *1	I _T (rms)	0.3	A
	Peak one cycle surge current	I _{surge}	3(50Hz sine wave)	A
	Repetitive peak off-state voltage	V _{DRM}	600	V
Isolation voltage *2		Viso(rms)	4.0	kV
Operating temperature		T _{opr}	-30 to +85	°C
Storage temperature		T _{stg}	-40 to +125	°C
Soldering temperature		T _{sol}	270 (For 10s)	°C

*1 The derating factors of absolute maximum rating due to ambient temperature are shown in Fig.3, 4.

*2 AC for 1min, 40 to 60%RH, f=60Hz

3.2 Electrical characteristics

Ta=25°C

Parameter		Symbol	MIN.	TYP.	MAX.	Unit	Conditions
Input	Forward voltage	V _F	-	1.2	1.4	V	I _F =20mA
	Reverse current	I _R	-	-	10	μA	V _R =3V
Output	Repetitive peak off-state current	I _{DRM}	-	-	100	μA	V _D =V _{DRM}
	On-state voltage	V _T	-	-	3	V	I _T =0.3A
	Holding current	I _H	-	-	25	mA	V _D =6V
	Critical rate of rise of off-state voltage	dv/dt	100	-	-	V/μs	V _D =1/√2 · V _{DRM}
Transfer characteristics	Minimum trigger current	I _{FT}	-	-	10	mA	V _D =6V, R _L =100Ω
	Isolation resistance	R _{ISO}	5 × 10 ¹⁰	10 ¹¹	-	Ω	DC500V 40 to 60%RH
	Turn on time	t _{ON}	-	-	100	μs	V _D =6V, R _L =100Ω, I _F =20mA

Fig.3 Forward current vs. ambient temperature(*1)

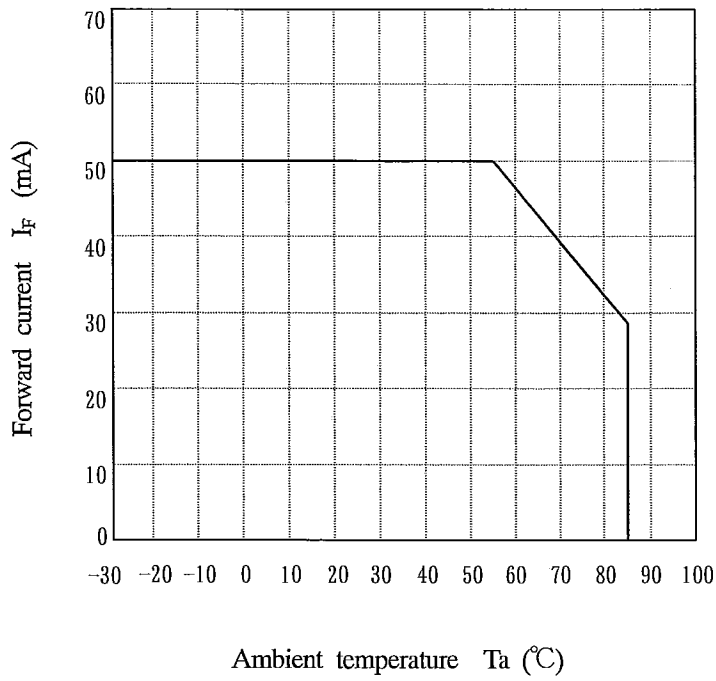
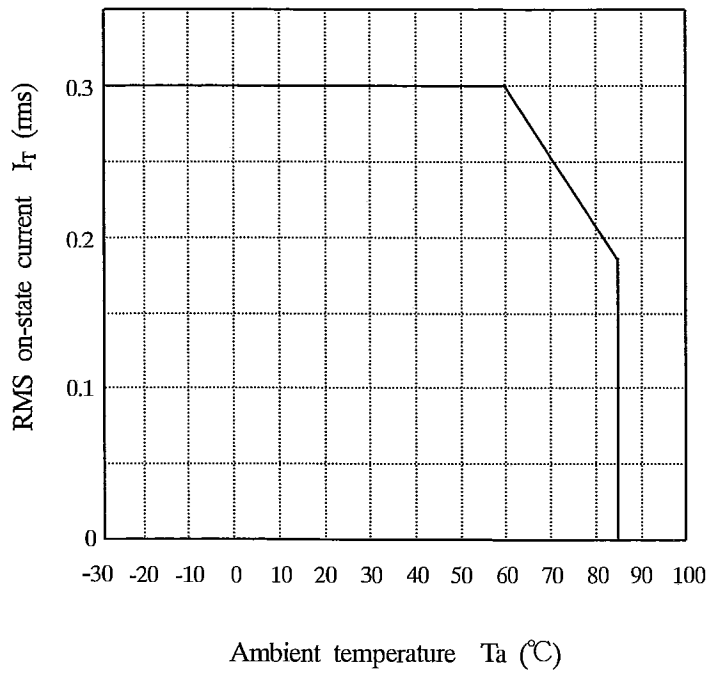

Fig.4 RMS on-state current vs. ambient temperature



4. Reliability

The reliability of products shall satisfy items listed below.

Confidence level : 90%
LTPD : 10 or 20

Test Items	Test Conditions *1	Failure Judgement Criteria	Samples (n)
			Defective(C)
Solderability	245±3°C, 5s	*2	n=11, C=0
Soldering heat *3	(Flow soldering) 270°C, 10 s	$V_F > U \times 1.2$ $V_T > U \times 1.2$ $I_{FT} > U \times 1.3$ $I_R > U \times 2.0$ $I_{DRM} > U \times 2.0$ U : Upper specification limit	n=11, C=0
	(Soldering by hand) 400°C, 3 s		n=11, C=0
Terminal strength (Tension)	Weight : 5N 5 s/each terminal		n=11, C=0
Terminal strength (Bending) *4	Weight : 2.5N 2 times/each terminal		n=11, C=0
Mechanical shock	15km/s ² , 0.5ms 3 times/± X, ± Y, ± Z direction		n=11, C=0
Variable frequency vibration	100 to 2000 to 100Hz/4min 200m/s ² 4 times/ X, Y, Z direction		n=11, C=0
Temperature cycling	1 cycle -40°C to +125°C (30min) (30min) 20 cycles test, Without Road		n=22, C=0
High temp. and high humidity storage	+60°C, 90%RH, 500h		n=22, C=0
High temp. storage	+125°C, 1000h		n=22, C=0
Low temp. storage	-40°C, 1000h		n=22, C=0
Operation life	I _F =50mA, I _T (rms)=0.3A T _a =25°C, 1000h	n=22, C=0	

*1 Test method, conforms to EIAJ ED 4701.

*2 The product whose not-soldered area is more than 5% for all of the dipped area and/or whose pinholes or voids are concentrated on one place shall be judged defect.

*3 Dip into the position of 0.2 mm from the resin part.

*4 Terminal bending direction is shown below.

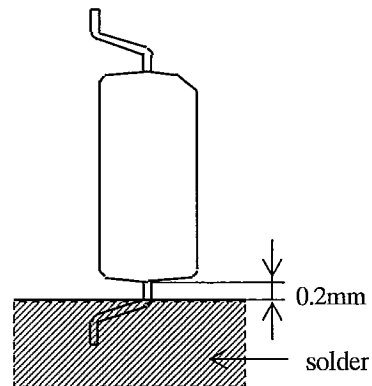
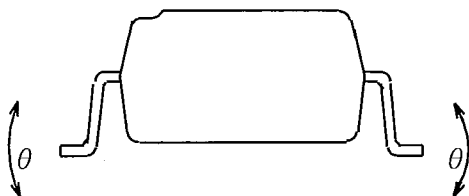

5. Outgoing inspection

5.1 Inspection items

(1) Electrical characteristics

$V_F, I_R, I_{DRM}, V_T, I_{FT}, R_{ISO}, V_{ISO}$

(2) Appearance

5.2 Sampling method and Inspection level

A single sampling plan, normal inspection level II based on ISO 2859 is applied.
The AQL according to the inspection items are shown below.

Defect	Inspection item	AQL (%)
Major defect	Electrical characteristics Unreadable marking	0.065
Minor defect	Appearance defect except the above mentioned.	0.25

6.2 Package specifications

6.2.1 Taping conditions

- (1) Tape structure and Dimensions (Refer to the attached sheet, Page 13)
The carrier tape has the heat pressed structure of A-PET material carries tape with preventing static electricity and three layers cover tape (PET material base).
- (2) Reel structure and Dimensions (Refer to the attached sheet, Page 14)
The taping reel shall be of plastic (PS material)
- (3) Direction of product insertion (Refer to the attached sheet, Page 14)
- (4) The cover tape and carrier tape in one reel shall be jointless.
- (5) To repair failure - taped devices, cutting a bottom of carrier tape with a cutter.
After replacing the cut portion shall be sealed with adhesive tape.

6.2.2 Adhesiveness of cover tape

The exfoliation force between carrier tape and cover tape shall be 0.2N to 0.7N for the angle 160° to 180° .

6.2.3 Rolling method and quantity

Wind the tape back on the reel so that the cover tape will be outside the tape.

Attach more than 20cm of blank tape to the trailer and the leader of the tape and fix the both ends with adhesive tape.

One reel basically shall contain 1000pcs.

6.2.4 Outer packing appearance (Refer to attached sheet, Page 14)

6.2.5 Marking

The outer packaging case shall be marked with following information.

* Model No.* (Business dealing name) * lot No. * quantity * country of origin

* Company name * inspection date specified

6.2.6 Storage condition

Taped products shall be stored at the temperature 5 to 30°C and the humidity 70%RH. or less away from direct sunlight.

6.2.7 Safety protection during shipping

There shall be no deformation of component or degradation of electrical characteristics due to shipping.

○Carrier tape structure and Dimensions

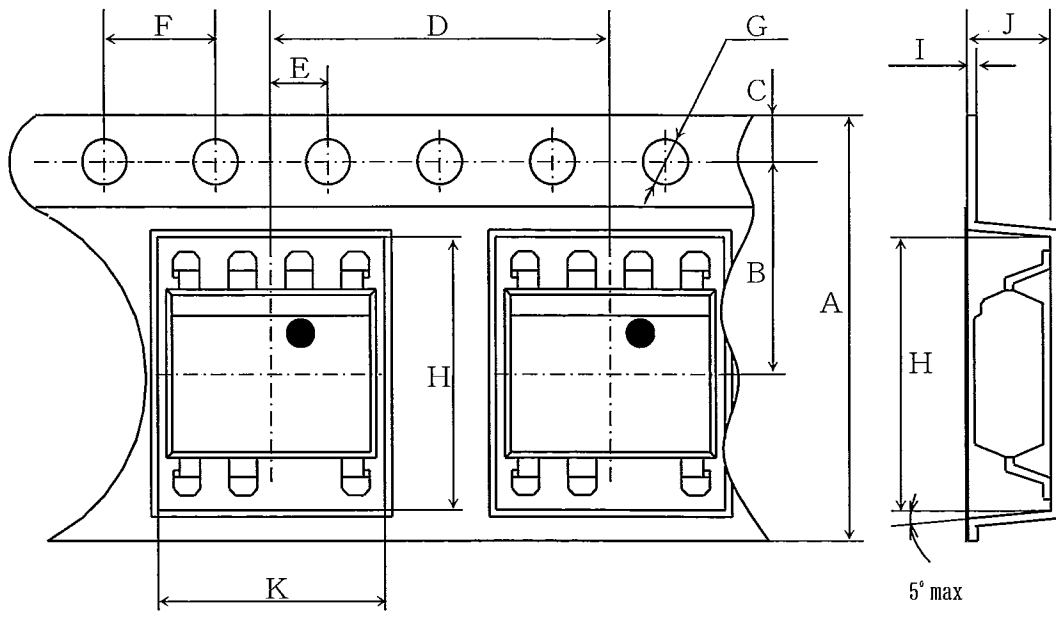

○Dimensions list (Unit : mm)

A	B	C	D	E	F	G	H	
16.0±0.3	7.5±0.1	1.75±0.10	12.0±0.1	2.0±0.1	4.0±0.1	φ1.5 ^{+0.1} ₋₀	10.4±0.1	
I	J	K						
0.40±0.05	4.2±0.1	10.2±0.1						

REFERENCE

PR33MF5TYPEF

○Reel structure and Dimensions

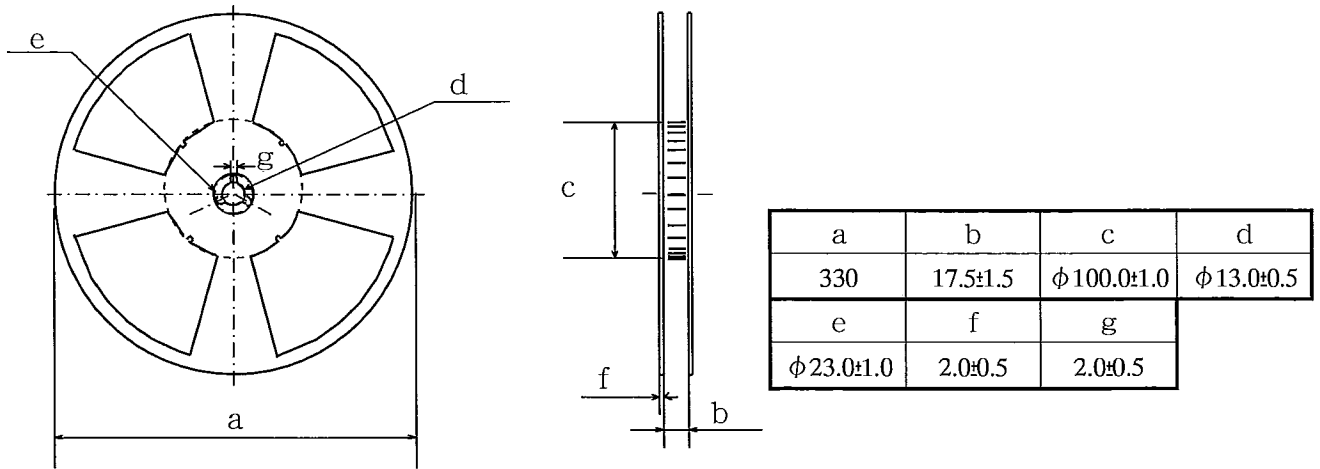

○Direction of product insertion

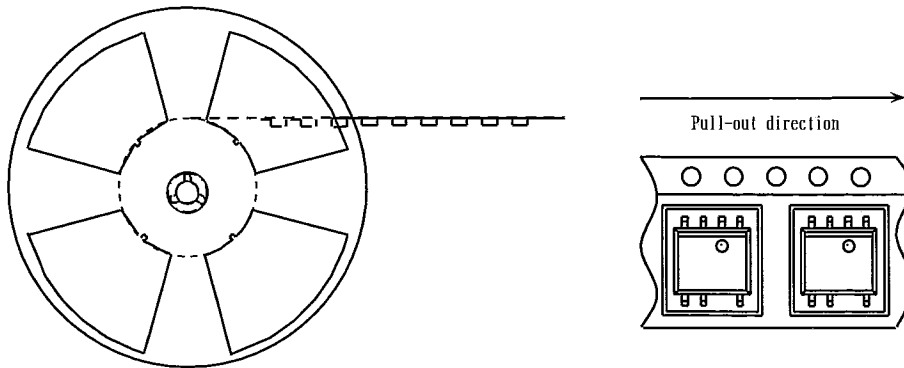

○Outer packing appearance

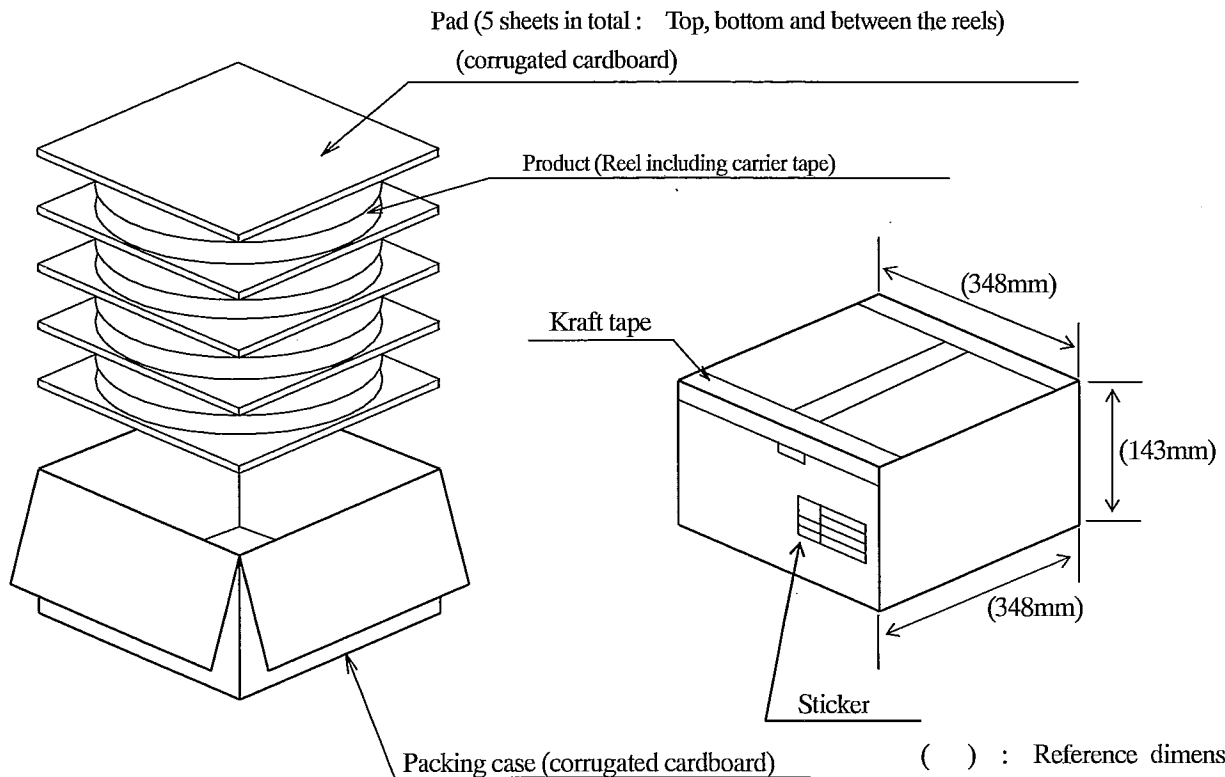

() : Reference dimensions
Regular packing mass: Approx. 4kg