

# mikroBuffer™

## Manual

*All Mikroelektronika's development systems feature a large number of peripheral modules expanding microcontroller's range of application and making the process of program testing easier. In addition to these modules, it is also possible to use numerous additional modules linked to the development system through the I/O port connectors. Some of these additional modules can operate as stand-alone devices without being connected to the microcontroller.*

# Additional board

 **MikroElektronika**

SOFTWARE AND HARDWARE SOLUTIONS FOR EMBEDDED WORLD ...making it simple

## mikroBuffer

The mikroBuffer additional board is used to amplify an analog voltage signal by using a unity gain amplifier. The amplified signal is then sent to the microcontroller analog inputs.

### Key features:

- Analog signal unity gain;
- Low power consumption; and
- 3.3V or 5V power supply voltage.

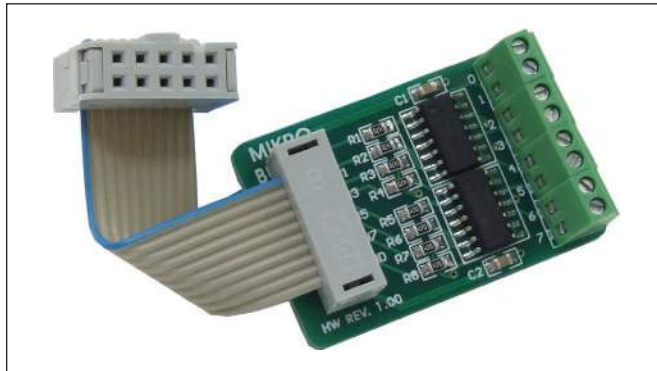

Figure 1: mikroBuffer additional board

### How to connect the board?

The mikroBuffer additional board can be easily connected to a microcontroller via an IDC10 connector CN1. Connectors CN2, CN3, CN4 and CN5 are used to establish connection between the board and a device that generates analog signal to be amplified. The board is powered with 3.3V or 5V DC power supply voltage via the CN6 connector.

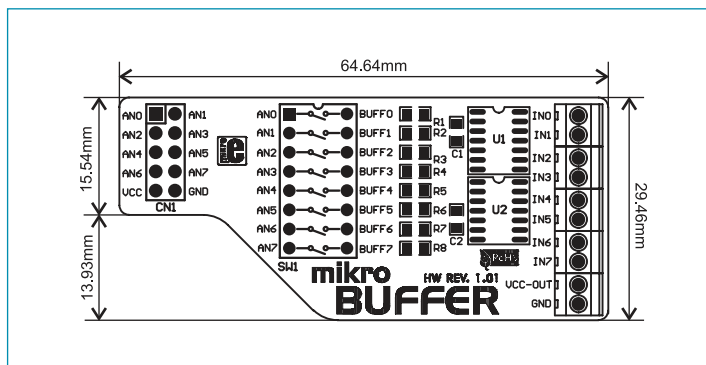

Figure 2: Dimensions of the mikroBuffer additional board

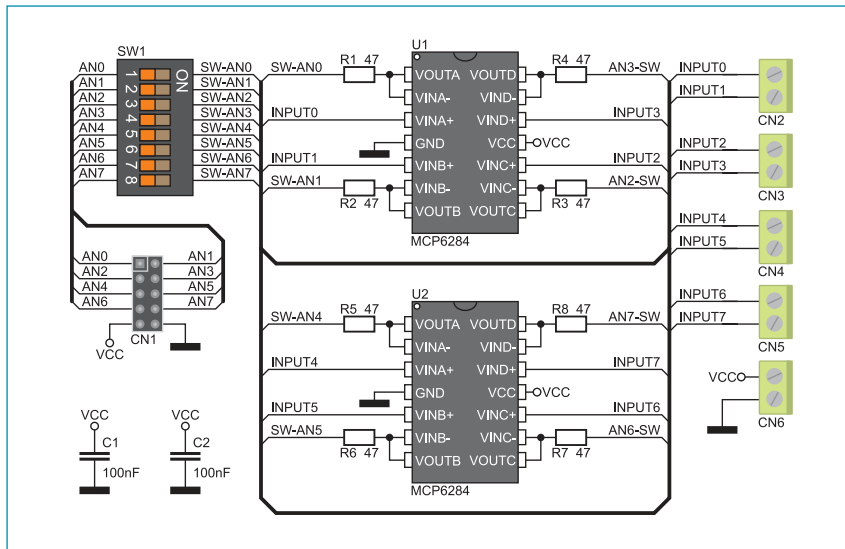

Figure 3: mikroBuffer board connection schematic



**MikroElektronika**  
SOFTWARE AND HARDWARE SOLUTIONS FOR EMBEDDED WORLD ...making it simple

If you want to learn more about our products, please visit our website at [www.mikroe.com](http://www.mikroe.com)

If you are experiencing some problems with any of our products or just need additional information, please place your ticket at [www.mikroe.com/en/support](http://www.mikroe.com/en/support)

If you have any questions, comments or business proposals, do not hesitate to contact us at [office@mikroe.com](mailto:office@mikroe.com)