

# SPECIFICATION CONTROL DRAWING

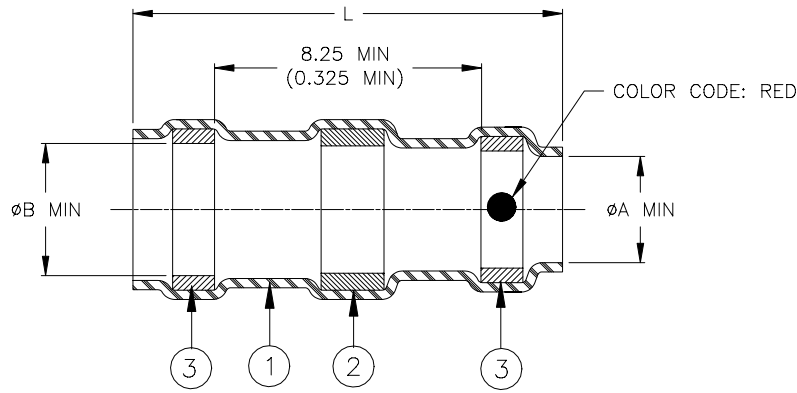

Product Revision		Ident Code	Product Dimensions			Cable Dimensions			
Product Name			L±1.75 (L±0.075)	øA min	øB min	øD max	øE max	øF min	øG min
SO175-1-00	A	SO1751R	16.50 (0.650)	1.90 (0.075)	2.67 (0.105)	1.90 (0.075)	2.67 (0.105)	0.90 (0.035)	0.50 (0.020)
SO175-2-00	A	SO1752R	16.50 (0.650)	2.67 (0.105)	3.68 (0.145)	2.67 (0.105)	3.68 (0.145)	1.40 (0.055)	0.75 (0.030)
SO175-3-00	A	SO1753R	16.50 (0.650)	4.32 (0.170)	5.08 (0.200)	4.32 (0.170)	5.08 (0.200)	2.15 (0.085)	1.25 (0.050)
SO175-4-00	A	SO1754R	19.10 (0.750)	5.97 (0.235)	6.48 (0.255)	5.97 (0.235)	6.48 (0.255)	3.30 (0.130)	1.80 (0.070)
SO175-5-00	A	SO1755R	19.10 (0.750)	6.98 (0.275)	7.62 (0.300)	6.98 (0.275)	7.62 (0.300)	4.30 (0.170)	2.50 (0.100)

## MATERIALS

- INSULATION SLEEVE: Heat-shrinkable, transparent blue, radiation cross-linked modified polyvinylidene fluoride.
- SOLDER PREFORM WITH FLUX AND THERMAL INDICATOR:
  - SOLDER: TYPE Sn96 per ANSI/J-STD-006.
  - FLUX: TYPE ROM1 per ANSI/J-STD-004.
  - THERMAL INDICATOR: Fusible ring, melt point: 232°C, completely melted at 240°C.
  - MELTABLE RINGS: Environment resistant thermoplastic. Color: blue.

## APPLICATION

- These parts are designed to provide an environment resistant shield termination on cables, rated for 150°C minimum, meeting the dimensional criteria listed, having nickel-plated shields and insulations compatible with the insert material. For compatible insulations, see MIL-S-83519/1 or consult Tyco Electronics/Raychem.
- When installed per Tyco Electronics/Raychem process standard RCPS-100-70, assemblies will meet performance requirement of Tyco Electronics/Raychem Specification RT-1404, MIL-S-83519, and 514.1920/99 Aerospatiale Matra Specification.
- Temperature range: -55°C to +175°C.  
For best results, prepare the cable as shown:

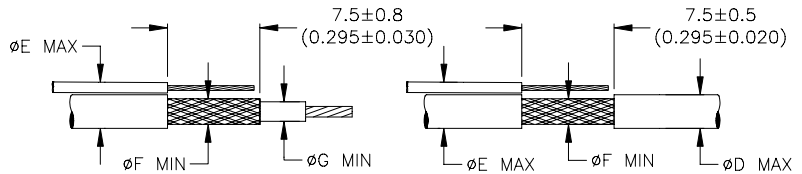

“G” is the minimum diameter on which the sleeve will seal.

SolderSleeve is a trademark of Tyco Electronics Corporation

		Tyco Electronics Corporation 300 Constitution Drive, Menlo Park, CA. 94025, U.S.A.				TITLE: <b>SOLDERSLEEVE SHIELD TERMINATOR,                  IMMERSION RESISTANT,                  175°C, LEAD-FREE</b>		
Unless otherwise specified dimensions are in millimeters. [Inches dimensions are shown in brackets]						DOCUMENT NO.: <b>SO175-X-00</b>		
TOLERANCES: 0.00 N/A 0.0 N/A 0 N/A		ANGLES: N/A ROUGHNESS IN MICRON		Tyco Electronics reserves the right to amend this drawing at any time. Users should evaluate the suitability of the product for their application.		PROD. REV.: SEE TABLE	DOC. ISSUE: 1	DATE: 25-Apr-03
DRAWN BY: M. FORONDA		CAGE CODE: 06090	REPLACES: D020140	DCR NUMBER: D030220	SCALE: None	SIZE: A	SHEET: 1 of 1	

If this document is printed it becomes uncontrolled. Check for the latest revision.

© 2004 Tyco Electronics Corporation. All rights reserved