

**Tool Kit**  
Order No. 64001-8870

## Application Tooling Specification Sheet

**Hand Crimp Tool**  
Order No. 64001-8800

### FEATURES

- % A full cycle ratcheting hand tool ensures complete crimps
- % Ergonomically designed soft handles
- % Precisely designed crimping profiles with simple contact positioning
- % Easy handling due to outstanding force ratio
- Tool kits are easily installed into the Hand Crimp Tool or the 63816-0300 Power Crimp Head which is installed into the 63816-0200 (110 V) or the 63816-0250 (220 V) Battery Powered Tool.
- Many different Tool kits can be used with a single Battery Powered Tool.

### SCOPE

Products: AviKrimp™ Fully Insulated and-Insulated Quick Disconnect Flags 10-12 AWG.

### Testing

#### Mechanical

The tensile test or pull test is a means of evaluating the mechanical properties of the crimped connections. The following chart shows the UL specifications for various wire sizes. The tensile strength is shown in pounds and indicates the minimum acceptable force to break or separate the terminal from the conductor.

Wire Size (AWG)	*UL - 310
12	70
10	80

\*UL – 310 – Quick Disconnects

### CONDITIONS:

The following is a partial list of the product part numbers and their specifications that this tool is designed to crimp. We will be adding to this list and an up to date copy is available on [www.molex.com](http://www.molex.com).

Wire Size: 10 – 12 AWG 5.00 – 3.30 mm <sup>2</sup>					
Terminal No.	Terminal Eng. No. (REF)	Wire Strip Length		Insulation Diameter Maximum	
		In.	mm	In.	mm
19006-0019	C-5211	.344	8.73	.245	6.22
19007-0040	C-2211	.344	8.73	.260	6.60
19007-0082	C-2211V	.344	8.73	.260	6.60

## DEFINITION OF TERMS

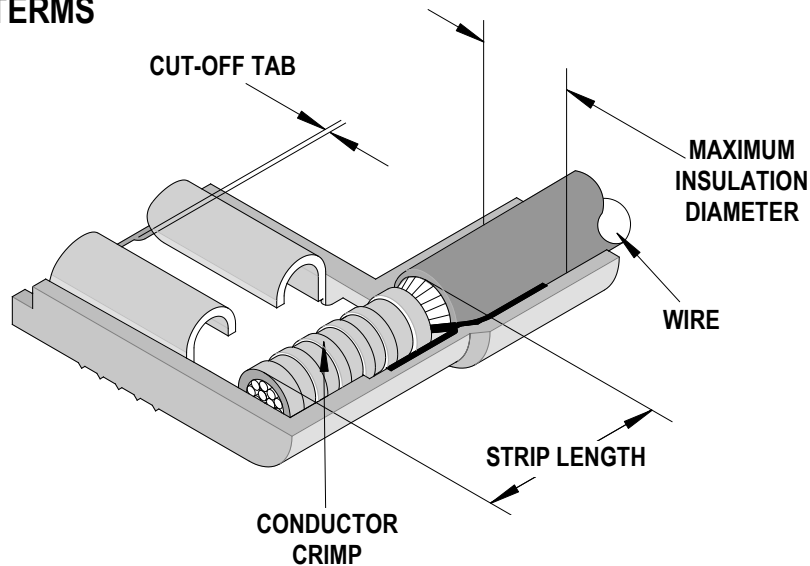

**CAUTION:** Install only Molex terminals listed above with this tool. Do not crimp hardened objects as damage can occur to the tool or die.

## INSTALLATION

To install the Tool Kit into the Power Crimp Head follow the steps below:

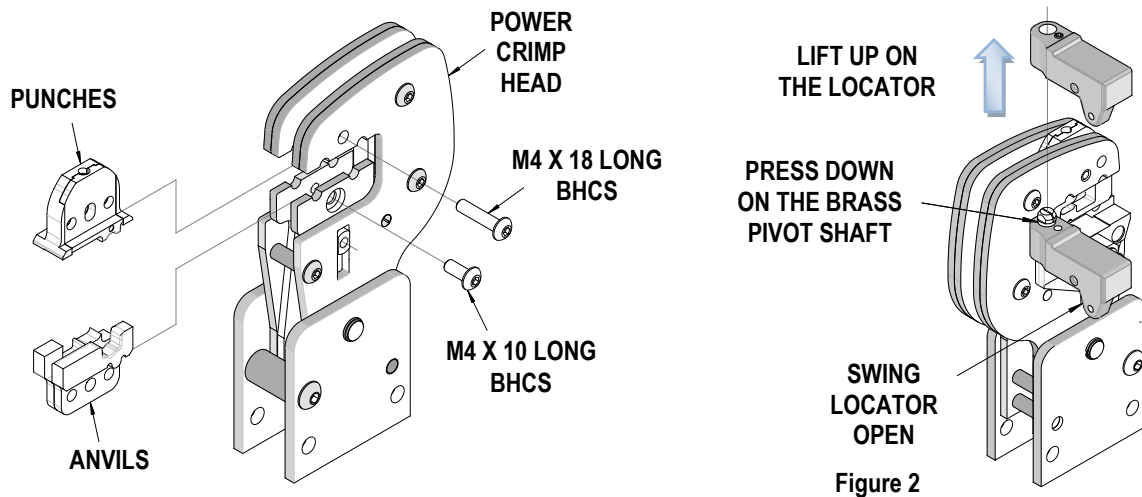

Figure 1

Figure 2

### Anvils and Punches Installation

1. Insert the Anvils into the bottom slots of the nest. Install the M4 x 10 long BHCS and tighten in place.
2. Insert the Punches into the top slots of the nest. Install the M4 x 18 long BHCS and tighten in place. See Figure 1.

### Locator Installation and Removal

Follow the steps below to install or replace the locator. See Figure 2.

#### To install the locator

1. Position the locator with the hole over the brass pivot shaft and snap it into place.

**To remove the locator**

1. Open the crimp hand tool.
2. Swing the existing locator open and away from the hand tool.
3. Firmly press down on the brass pivot shaft with your thumb, while pulling the locator up. Slip the locator off the top of the brass pivot shaft.

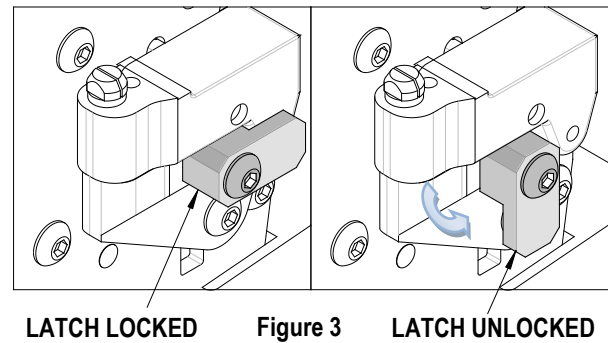

**OPERATION**

Open the tool by squeezing the handles together, at the end of the closing stroke, the ratchet mechanism will release the handles, and the hand tool will spring open.

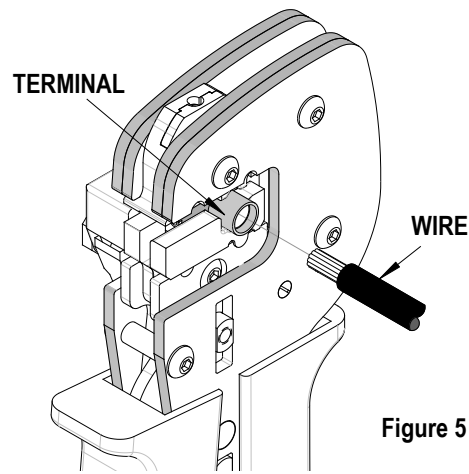
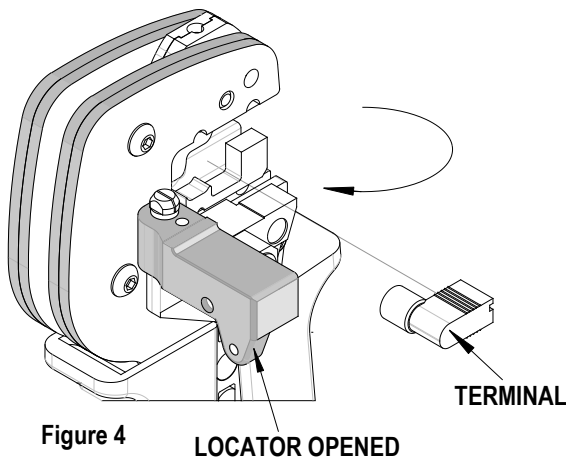

**Loading and Crimping Terminals**

Terminals may be loaded when locator is swung open, however when swinging the locator into crimping position, the spring loaded locator may need to be pushed down to clear the tooling. Swing the terminal locator against the crimp tool and turn lock up to lock the locator. Terminals may also be loaded easily while locator is up against the crimp tool and locked. See Figure 3 and 4.

1. Insert the terminal with the barrel into the nest and the square edge of the flag facing out. Make sure the back of the flag terminal is against the locator. When the locator is against the crimp tool and locked, the terminal is now in proper position for crimping.
2. Partially close the tool to hold the terminal in place.
3. Insert the properly stripped wire into the terminal barrel. See Figure 5. The wire ends should butt against the inside of the connector. See Figure 6. Cycle the tool.

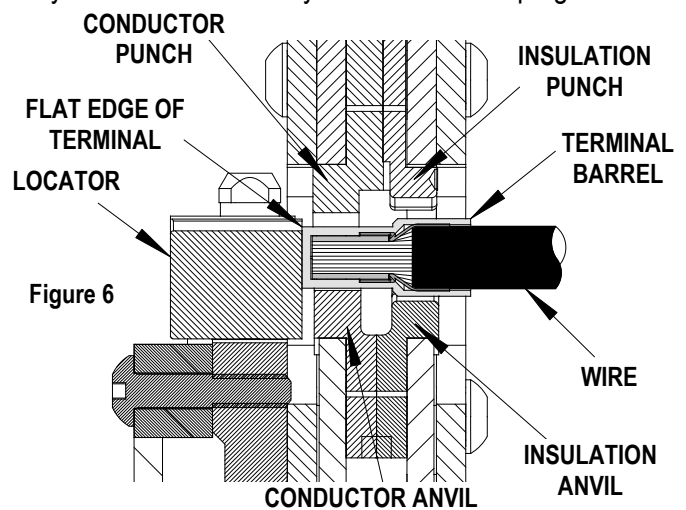

**Note:** The tamper proof ratchet action will not release the tool until it has been fully closed.

4. Remove the crimped terminal. Inspect for proper crimp location, and check for insulation damage.
5. Visually inspect the crimped terminal for proper insulation crimp closure.
6. If the insulation part of the crimp needs to be adjusted, first loosen the M4 screw on the upper tool jaw. Then insert a 2.5mm hex wrench (supplied) into the set screw at the top of the upper die. See Figure 7. A clockwise (CW) rotation decreases insulation crimp while a counter-clockwise (CCW) rotation increases insulation crimp. After adjusting, retighten the M4 screw.

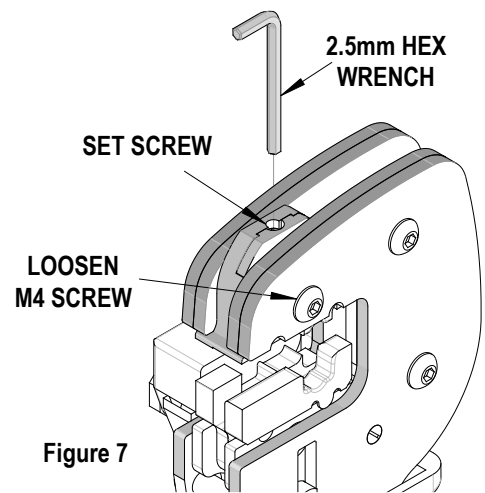

**Note:** The tamper proof ratchet action will not release the tool until it has been fully closed.

### For the Battery Power Tool:

1. Cycle the Battery Power Tool to crimp the terminal to the wire.
2. Remove the crimped terminal from the terminal locator by pressing down on the wire stop and gently pulling on the wire. The terminal locator can be in either position.
3. Visually inspect the crimped terminal for proper crimp location.

### Maintenance

It is recommended that each operator of the tool be made aware of, and responsible for, the following maintenance steps:

1. Remove dust, moisture and other contaminants with a clean brush, or soft, lint-free cloth.
2. Do not use any abrasive materials that could damage the tool.
3. Make certain all pins; pivot points and bearing surfaces in the tool head are protected with a thin coat of high quality machine oil. Do not oil excessively. This tool was engineered for durability, but like any fine piece of equipment, it needs cleaning and lubrication for a maximum service life of trouble-free crimping. The use of a light oil, such as 30 weight automotive oil, every 5,000 crimps or monthly, will significantly enhance the tool life and ensure a stable calibration. See Figure 8A or 8B for lubrication points.
4. Store the tool in a clean and dry area when not in use.

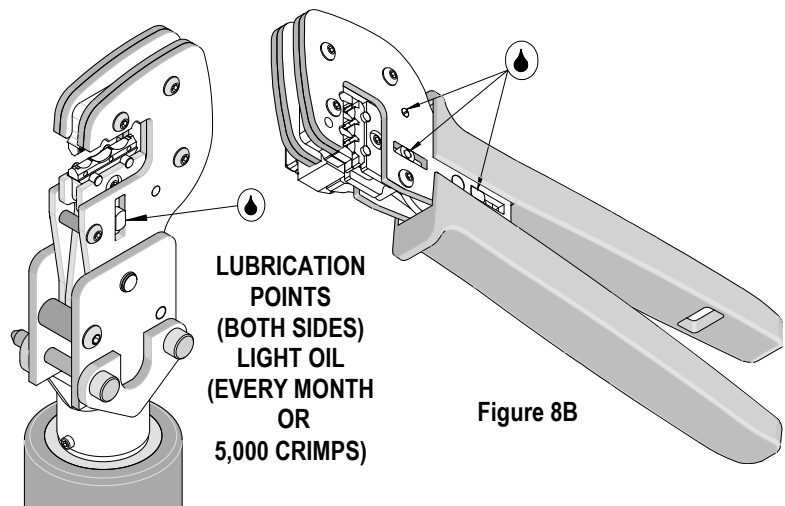

### Miscrimps or Jams for Hand Crimp Tools Only (See Figure 12)

Should this tool ever become stuck or jammed in a partially closed position, **Do Not force the handles open or closed.** The tool will open easily by rotating the small slotted screw marked with an arrow. See Figure 12.

## Tool Calibration

A Certificate of Calibration (see last page) was supplied with the tool. To recalibrate this tool, pin gauge measurements should be taken in each conductor nest and compared to this chart. The tool should be lubricated prior to recalibration to ensure consistent measurements. Handle preload is factory set to 25-45 LBS. See How to Adjust Tool Preload, see Figure 5 to recalibrate.

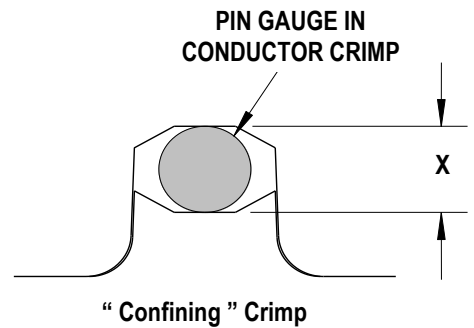

Nest Color Code	Wire Range		"X" Dimension Conductor Crimp						Crimp Inspection Marking
			Mean		Go		No Go		
	AWG	mm <sup>2</sup>	In.	mm	In.	mm	In.	mm	
Yellow	10 - 12	5.00-3.30	.115	2.92	.112	2.84	.118	3.00	o

## Warranty

This tool kit is for electrical terminal crimping purposes only. This tool kit is made of the best quality materials. All vital components are long life tested. All tools are warranted to be free of manufacturing defects for a period of 30 days. Should such a defect occur, we will repair or exchange the tool kit free of charge. This repair or exchange will not be applicable to altered, misused, or damaged tools.

**CAUTION:** Molex crimp specifications are valid only when used with Molex terminals and tooling.

## CAUTIONS

1. Manually powered hand tools are intended for low volume or field repair. This tool is **NOT** intended for production use. Repetitive use of this tool should be avoided.
2. Insulated rubber handles are not protection against electrical shock.
3. Wear eye protection at all times.
4. Use only the Molex terminals specified for crimping with this tool.

**CAUTION:** Repetitive use of this tool should be avoided.

## Certification

Molex does not certify or re-certify commercial grade hand tools but rather supplies the following guidelines for customers to re-certify hand tools.

- % This tool is qualified to pull force only. To re-certify, crimp a terminal to a wire, which has been stripped 12.7mm (1/2") long, so there is no crimping of the insulation. Pull the terminal and wire at a rate no faster than 25mm (1.00") per minute. See the Molex web site for the Quality Crimp Handbook for more information on pull testing.
- % When the hand tool is no longer capable of achieving minimum pull force, it should be taken out of service and replaced.
- % This tool is very difficult to disassemble and reassemble. Customer repair is not recommended.

The chart below shows all applications for this Tool Kit.

Tool Kit Order No.	Tool Order no.	Tool Description	Power Head Order No.	Adapter Description	Figure No.
64001-8870	63810-1050	Hand Crimp Frame (Short)	N/A	N/A	10
	63810-1000	Hand Crimp Frame (Long)	N/A	N/A	10
	63816-0200	Battery Power Tool (110 V)	63816-0300	Power Crimp Head	11
	63816-0250	Battery Power Tool (220 V)	63816-0300	Power Crimp Head	11

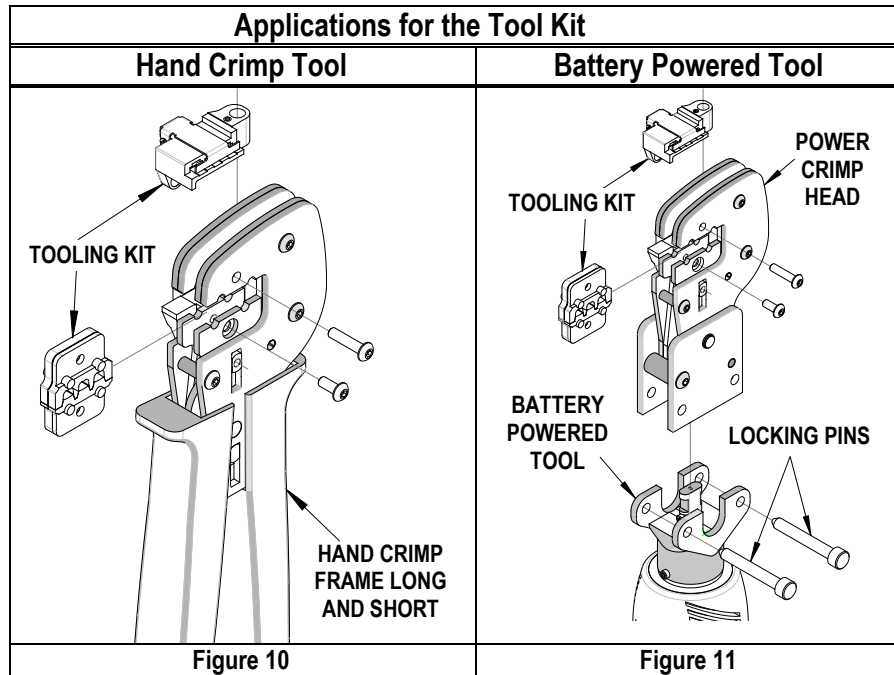

**WARNING:** NEVER operate service, install tool kits, or adjust the Power Crimp Head without proper instruction and without first reading and understanding the instructions in the proper Manual or Specification Sheet. See Chart above for the correct Manual or Specification Sheet.

**WARNING:** NEVER install tooling or service this tool while it is into any power source. Make sure the power is turned off.

**CAUTION:** Keep fingers away from the crimping area when operating this tool. It may cause severe injury.

**CAUTION:** Wear safety glasses when operating or serving this tool.

### HAND TOOL PARTS LIST

Item Number	Order Number	Description	Quantity
1	63810-1000	Hand Crimp Frame (Long)	1
2	64001-8870	Tool Kit with Locator	1
3	63811-4773	Locator Base	1
4	64001-8875	Locator	REF

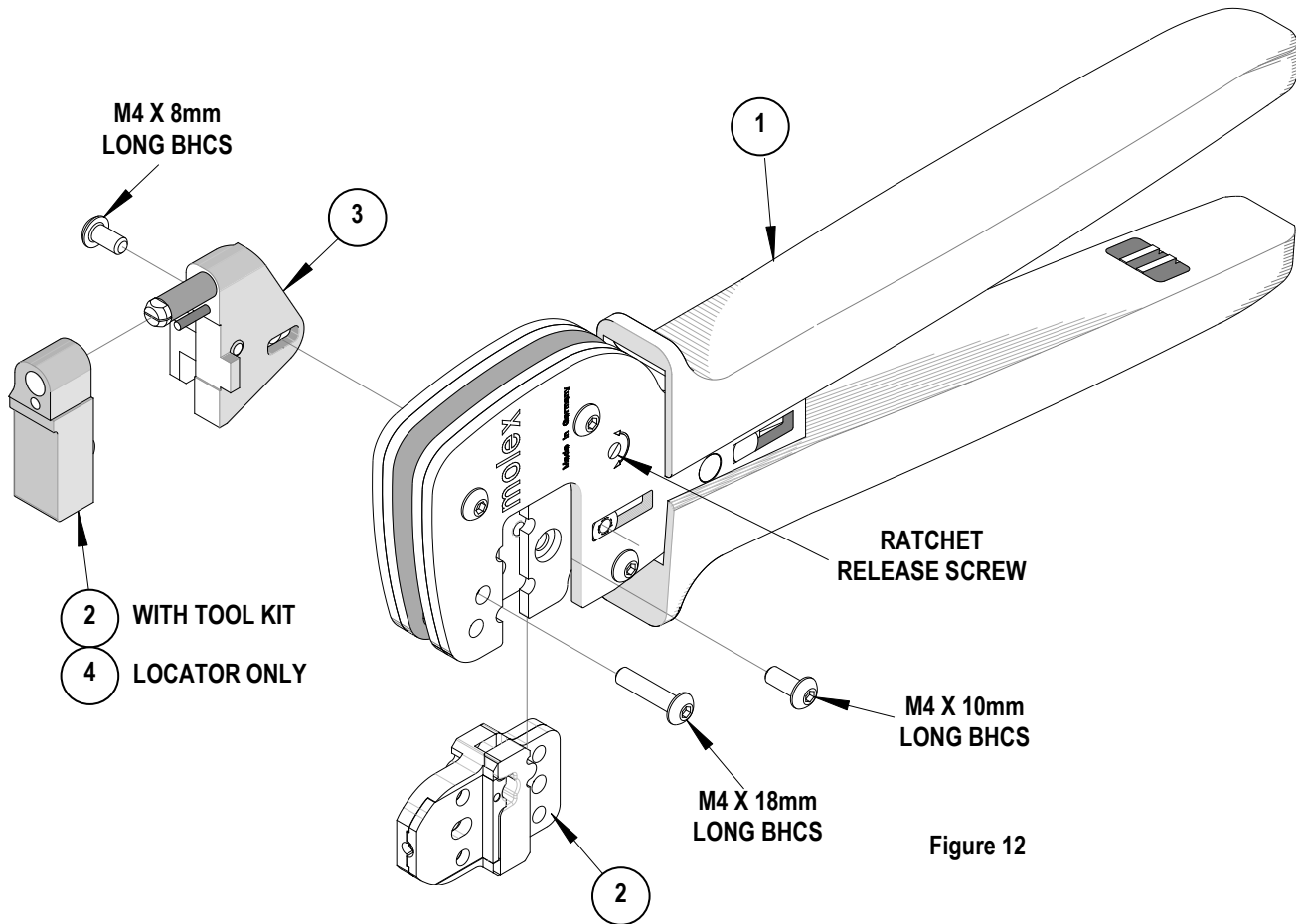

### POWER HEAD PARTS LIST

Item	Order No	Engineering No.	Description	Quantity
1	63816-0300	63816-0300	Power Crimp Head	1
2	64001-8870	64003-1570	Tool Kit	1

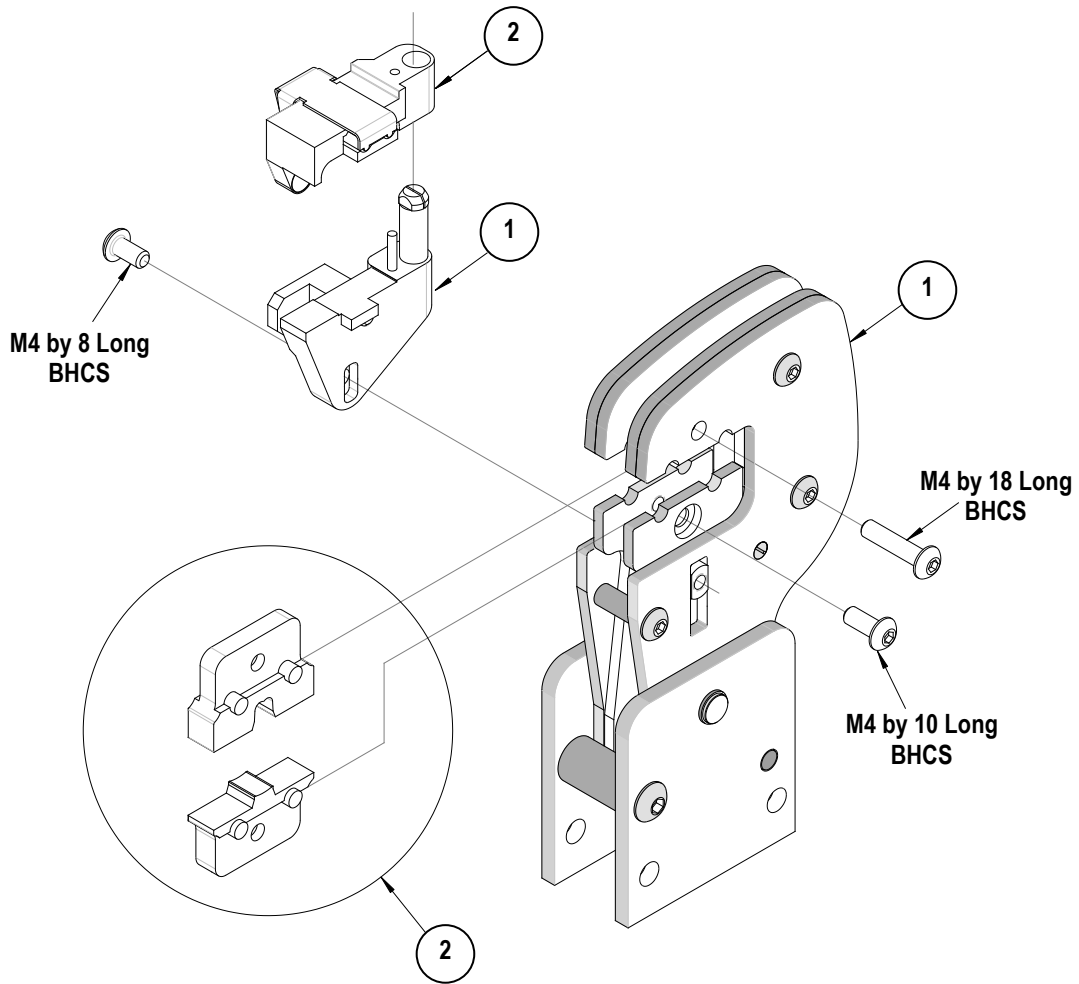

Figure 11



**Hand Crimp Tool  
AviKrimp™**

**molex®**

**Certificate of Calibration**

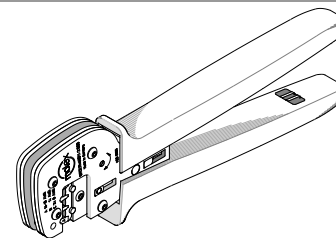

**Order No. 64001-8800**

Tool Order Number \_\_\_\_\_

Tool Revision \_\_\_\_\_

Serial Number \_\_\_\_\_

Date of Manufacture \_\_\_\_\_

Handle Load Range at 1 inch from the Tips = \_\_\_\_\_

Actual = \_\_\_\_\_

Pin Gauge of Conductor Nest/Nests or Slug height if the nest is the "F" Crimp style.

Range, Conductor Nest = \_\_\_\_\_ -- Actual = \_\_\_\_\_

Technician \_\_\_\_\_

Date of Calibration \_\_\_\_\_

Calibration should be done every 5,000 cycles or 3 months.  
Tools should be lubricated during this operation.

Visit our Web site at <http://www.molex.com>