

# SCR490D

## Obstruction Lamp Alarm Relay

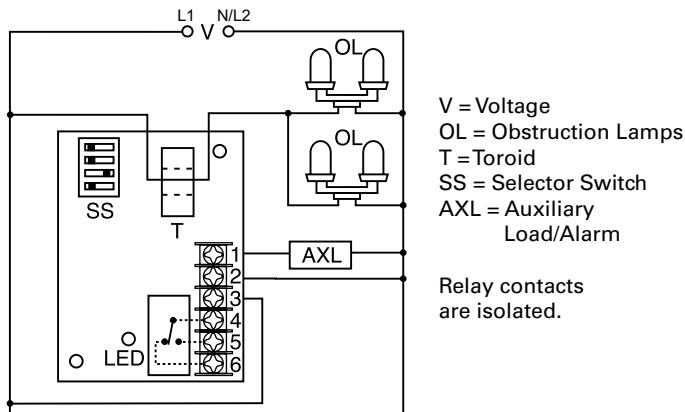

### Wiring Diagram



### Description

The SCR490D is used to provide remote monitoring of steady burning incandescent marker and obstruction lighting. Four onboard switches allow operator programming for lighting systems with two through nine lamps on a single AC circuit. The SCR490D uses a toroidal sensor and electronic circuitry to sense the failure of one or more lamps.

### Operation

When a lamp fails, the SCR490D senses a decrease in current flow. Then, after a fixed time delay, it transfers to its alarm mode. In alarm mode, the LED indicator, the output relay (SPDT isolated contacts), and a non-isolated solid-state output are energized. Replacement of the failed lamps resets the alarm outputs and the LED indicator. To prevent false alarm signals, power must be applied to the SCR490D at the same time that lamps are energized.

### Features & Benefits

FEATURES	BENEFITS
<b>Toroidal current sensing</b>	Reliable low cost monitoring of incandescent marker and obstruction lighting through built-in CT which also provides isolation from the lighting circuit
<b>Monitors 2 - 9 lamps</b>	Senses failed obstruction lamps on a single AC circuit
<b>Isolated, 10A, SPDT alarm output plus one 1A, solid-state line voltage alarm output</b>	Provide alarm indication and can also be used for remote monitoring of the lighting system
<b>Fixed trip delay (6s)</b>	Prevents nuisance alarms

### Specifications

#### Operation

<b>Number of Lamps</b>	2 - 9 (selectable)
<b>Lamp Wattage</b>	116W, incandescent lamps
<b>Rated Lamp Voltage</b>	120 or 130VAC (selectable)
<b>Monitored Voltage</b>	120VAC $\pm$ 3%
<b>Trip Delay</b>	$\approx$ 6s fixed
<b>Voltage</b>	120VAC
<b>AC Line Frequency</b>	50/60Hz
<b>Tolerance</b>	- 20% - 10%
<b>120VAC Line Voltage Output (Solid State Rated)</b>	$\leq$ 125W to operate a spare lamp or alarm
<b>Isolated Alarm Output</b>	10A @ 120VAC or 30VDC resistive; 1/4 hp @ 125VAC; 1/2 hp @ 250VAC
<b>Mounting</b>	Surface mount with two #6 (M3.5 x 0.6) screws
<b>Dimensions</b>	<b>H</b> 88.9 mm (3.5"); <b>W</b> 63.5 mm (2.5"); <b>D</b> 44.5 mm (1.75")
<b>Termination</b>	Screws with captive clamps for up to 14 AWG (2.45 mm <sup>2</sup> ) wire
<b>Circuitry</b>	Encapsulated
<b>Operating/Storage Temperature</b>	-55° to 65°C / -55° to 85°C
<b>Humidity</b>	95% relative, non-condensing
<b>Weight</b>	$\approx$ 6.8 oz (193 g)