

SYNCHRONOUS RECTIFIER DRIVER

Features

- Provides constant and proper gate drive to power MOSFETs regardless of transformer output
- Minimizes loss due to power MOSFET body drain diode conduction
- Stand alone operation - no ties to primary side
- Schmitt trigger input with double pulse suppression allows operation in noisy environments
- High peak current drive capability - 4A
- High speed operation - 2MHz
- Adaptable to multiple topologies

Description

The IR1176 is a high speed CMOS controller designed to drive N-channel power MOSFETs used as synchronous rectifiers in high current, high frequency forward converters with output voltages equal or below 5VDC. Schmitt trigger inputs with double pulse suppression allow the controller to operate in noisy environments. The circuit does not require any ties to the primary side and derives its operating power directly from the secondary. The circuit functions by anticipating transformer output transitions, then turns the power MOSFETs on or off before the transitions of the transformer to minimize body drain diode conduction and reduce associated losses. Turn on/off lead time can be adjusted to accommodate a variety of power MOSFET sizes and circuit conditions. The IR1176 also provides gate drive overlap/dead-time control via external components to further minimize diode conduction by nulling effects of secondary loop and device package inductance.

Product Summary

V _{dd}	5Vdc
I _{O+/-} (peak)	4A/4A
F _{max}	2MHz
Max lead time	500nsec

Packages



IR1176S
 20 Lead Surface Mount
 (SSOP-20)

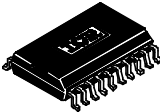

IR1176SS
 20 Lead SOIC (MS-013AC)

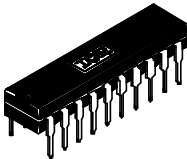

IR1176
 20 Lead PDIP
 (MS-001AD)

Absolute Maximum Ratings

Absolute maximum ratings indicate sustained limits beyond which damage to the device may occur.

Symbol	Definition	Min.	Max.	Units
V _{DD}	Supply voltage	—	7	V _{DC}
I _{in}	Input clamp current	—	+/- 10	mA _{DC}
P _D	Power dissipation (SSOP-20)	—	400	mW
	(SOIC)	—	—	—
	(PDIP)	—	—	—
R _{thJC}	Thermal resistance (SSOP-20) junction-to-case	—	28.5	°C/W
	(SOIC) junction-to-case	—	20	
	(PDIP) junction-to-case	—	28.1	
R _{thJA}	Thermal resistance (SSOP-20) junction-to-ambient	—	90.5	
	(SOIC) junction-to-ambient	—	45	
	(PDIP) junction-to-ambient	—	62.4	
T _J	Junction temperature	—	150	°C
T _S	Storage temperature	-55	150	
T _L	Lead temperature (soldering, 10 seconds)	—	300	

Recommended Operating Conditions

Symbol	Definition	Min.	Typ.	Max.	Units
V _{DD}	Supply voltage operating range	—	5	—	V _{DC}
T _A	Ambient temperature	-40	—	85	°C
Freq	Operating frequency	250	—	500	KHz
R _{bias}	Required bias resistor (+/- 1%)	—	34.0	—	KΩ
UV	Voltage at UVSET pin	1.75	—	2.25	V _{DC}
X _{in}	Maximum voltage at X1 and X2 inputs	—	—	5.6	V _{DC}
Cd1/Cd2	Capacitance at pins DTIN1 and DTIN2	—	—	100	pF

Dynamic Electrical Characteristics

V_{dd}=5V, T_A = 25°C, R_{bias} = 34.0K unless otherwise specified.

Symbol	Definition	Min.	Typ.	Max.	Units
V _{dd}	Supply voltage operating range	4.0	—	5.25	V _{DC}
I _{qdd}	V _{dd} quiescent current (x1 = x2 = 0V or 5V, I _{out} = 0)	—	4	5	A
Freq	Operating frequency	100	—	2000	KHz
UVSET+	UVSET positive going threshold	1.10	—	1.4	V
UVSET-	UVSET negative going threshold	0.8	—	1.1	V
V _{xth+}	X1/X2 Input positive going threshold	—	1.4	—	V _{DC}
V _{xth-}	X1/X2 Input negative going threshold	—	1.0	—	V _{DC}
T _{adv}	Externally adjustable lead time (advance)	—	—	500	nsec
T _d	Externally adjustable dead-time for Q1 and Q2	20	—	—	nsec
I _{sink} (peak)	Q1,Q2 output sink current (V _{dd} =5.0V, pulsed, 10 usec)	—	4	—	A
I _{source} (peak)	Q1,Q2 output source current (V _{dd} =5.0V, pulsed, 10 usec)	—	4	—	
VOH	Q1, Q2 High level voltage (I _{out} = 20mA)	—	V _{dd} - 0.20	—	V
VOL	Q1, Q2 Low level voltage (I _{out} = 20mA)	—	0.10	—	
t _{io}	Input to output delay (PLL bypassed, cross coupled mode)	—	20	—	nsec
t _r	Gate turn-on rise time (C1=1000pf, V _{dd} =5V)	—	20	—	nsec
t _f	Gate turn-off fall time (C1=1000pf, V _{dd} =5V)	—	20	—	nsec
V _{tr}	Cross-over voltage (V _{dd} =5V _{dc} , DTIN shorted to DTOUT, C1=1000pf) Fig. 3	—	2.5	—	V _{DC}
R _{bias}	Required bias resistor (1%)	—	34.0	—	KΩ
V _{bias}	Voltage at R _{bias} pin	—	1.25	—	V _{DC}
T _{jitter}	Phase-lock loop output jitter	-20	—	20	nsec
I _{chg} pump	Charge pump output current (at VFLTR pin)	—	50	—	μA _{DC}
V _{chg} pump	Charge pump output voltage (at VFLTR pin)	1.3	1.5	1.7	V _{DC}
K _{vco_dc}	PLL V _{co} DC gain (per design)	—	62	—	KHz/ Volt

Lead Definitions and Assignments

Symbol	Description
AVDD	Power - + 5 V _{DC} to MOSFET drivers
Q1	Output - gate drive for Q1 power MOSFET
DTOUT1	Output - sets dead time for Q1 output - used with DTIN1
DTIN1	Input - sets dead time for Q1 - used with DTOUT1
RADV1	Output - sets lead time (advance) for Q1
VFLTR1	Output - PLL loop filter for Q1 output
RVCO1	Output - sets PLL center frequency for Q1 output
X1	Input - transformer input for Q1
VDD	Power - +5 Vdc for internal logic
UVSET	Input - sets UVLO+ If this pin is pulled below 1.25VDC externally, then both Q1 and Q2 outputs will be at Vss (disabled)
RBIAS	Output - connected to 34.0K +/- 1% resistor - sets operating current
AVSS	Ground for MOSFET driver supply (VDD)
X2	Input - transformer input for Q2
RVCO2	Output - sets PLL center frequency for Q2 output
VFLTR2	Output - PLL loop filter for Q2
RADV2	Output - sets lead time (advance) for Q2
DTIN2	Input - sets dead time for Q2 - used with DTOUT2
DTOUT2	Output - sets dead time for Q2 - used with DTIN2
VSS	Ground for logic supply (AVDD)
Q2	Output - gate drive for Q2 power MOSFET

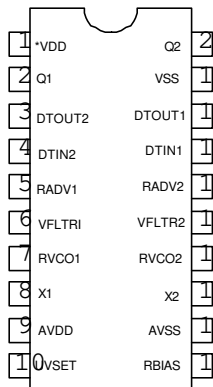

IR1176S
(SSOP-20)

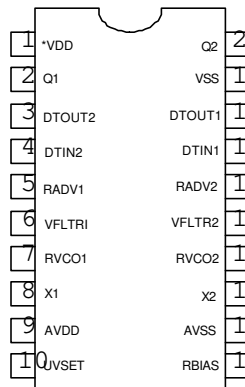

IR1176SS
SOIC (wide body)

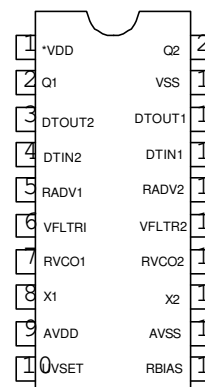

IR1176
PDIP

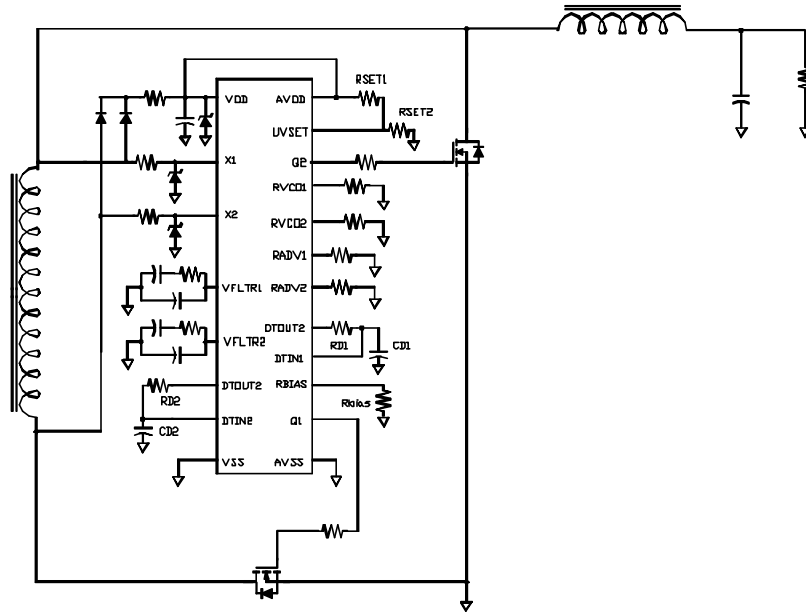

Fig. 1 Typical application circuit when supply $V_{out} < 5.0 V_{DC}$

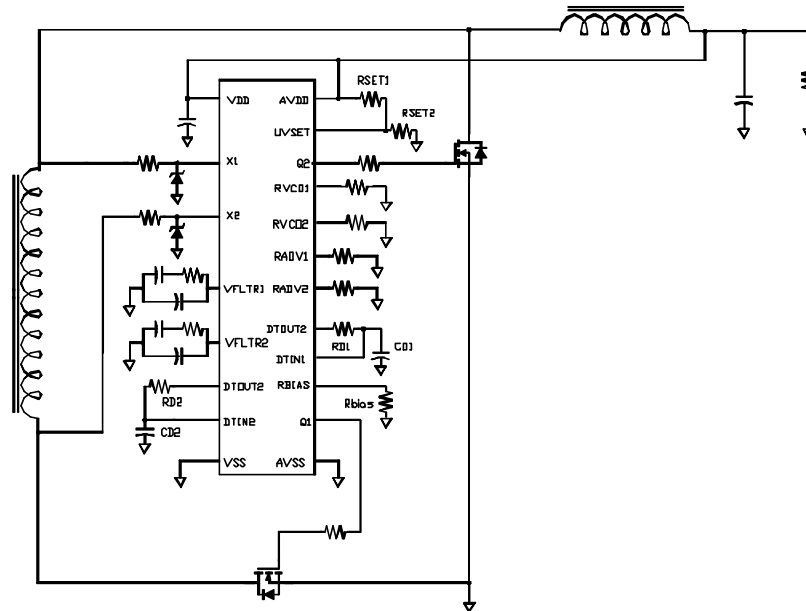

Fig. 2 Typical application circuit when supply $V_{out} = 5.0 V_{DC}$

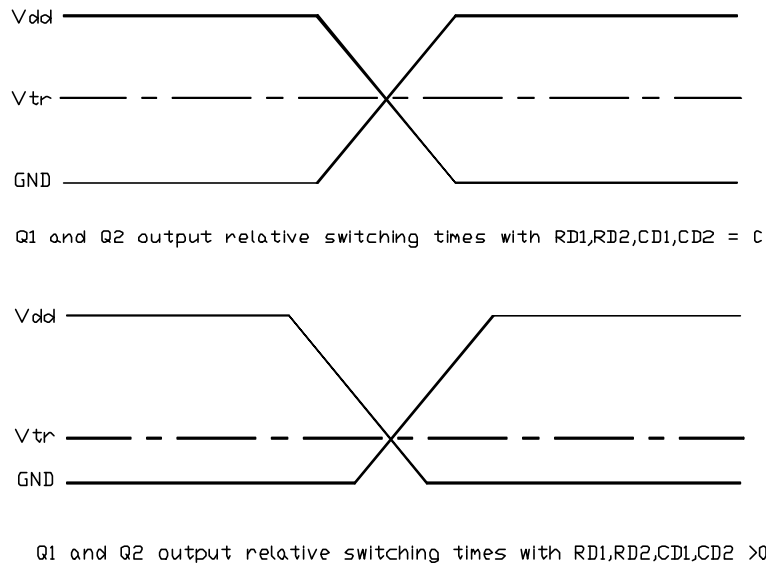

Fig. 3 Gate drive characteristics and definitions

Phase Lock Loop Design Equations:

1 - Resistor to set VCO Center Frequency:

$$R_{vco} (K\Omega) = [1E2 \times V_{chgpump}(V_{DC}) / f_{vco}(KHz)] \times K_{vco_dc}(KHz/Volt)$$

Example (A): Choose $V_{chgpump} = 1.5V$, desired frequency (f_{vco}) = 300KHz

$$R_{vco} = [1E2 \times 1.5 / 300] \times 62 \text{ Hz} = 31 \text{ K}\Omega$$

2 - Small Signal gain for VCO:

$$K_{vco_ac} (KHz/Volt) = 1E2 \times K_{vco_dc} (KHz/Volt) / R_{vco}(K\Omega)$$

Example (B): Choosing same conditions as in example A:

$$K_{vco_ac} = 1E2 \times 62 / 31 = 200 \text{ KHz/volt}$$

3 -PLL Natural frequency:

$$\omega_n = 2\pi f_n(\text{KHz}) = \sqrt{I_{\text{chpump}}(\mu\text{A}) \times K_{\text{vco_ac}}(\text{KHz/V}) / C(\text{nF})}$$

Choose C_f such that $C_f = C/16$

4 -PLL Damping factor calculations:

$$P = \pi E^{-3} \times R_f(\text{K}\Omega) \times C(\text{nF}) \times f_n(\text{KHz})$$

Typical value for P is 0.707. (Critically damped)

5 -Advance timing:

$$T_{\text{adv}}(\text{nsec}) = R_{\text{ADV}}(\text{K}\Omega) \times 10 + 6$$

Where R_{ADV} is resistance from R_{ADV1} or R_{ADV2} to ground.

Example C: $R_{\text{ADV}} = 10\text{K}\Omega$ will result in $T_{\text{adv}} = 10 \times 10 + 6 = 106$ nsec.

6 -Dead time calculations:

$$T_d(\text{nsec}) = 0.69 \times C_{\text{dt}}(\text{pF}) \times (R_{\text{dt}}(\text{K}\Omega) + 0.15) \text{ (For } V_{\text{dd}} = 5\text{V)}$$

Where R_{dt} is resistance between pins DTIN1 and DTOUT1 or DTIN2 and DTOUT2 . C_{dt} is capacitance from DTIN1 or DTIN2 to ground.

Example D: $R_{\text{d}} = 2\text{K}\Omega$ and $C_{\text{dt}} = 100\text{pF}$ will result in $T_d = 148.35\text{nsec}$.

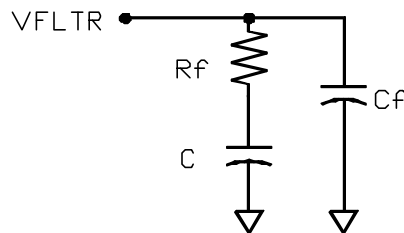

Fig. 4 PLL loop filter component definitions

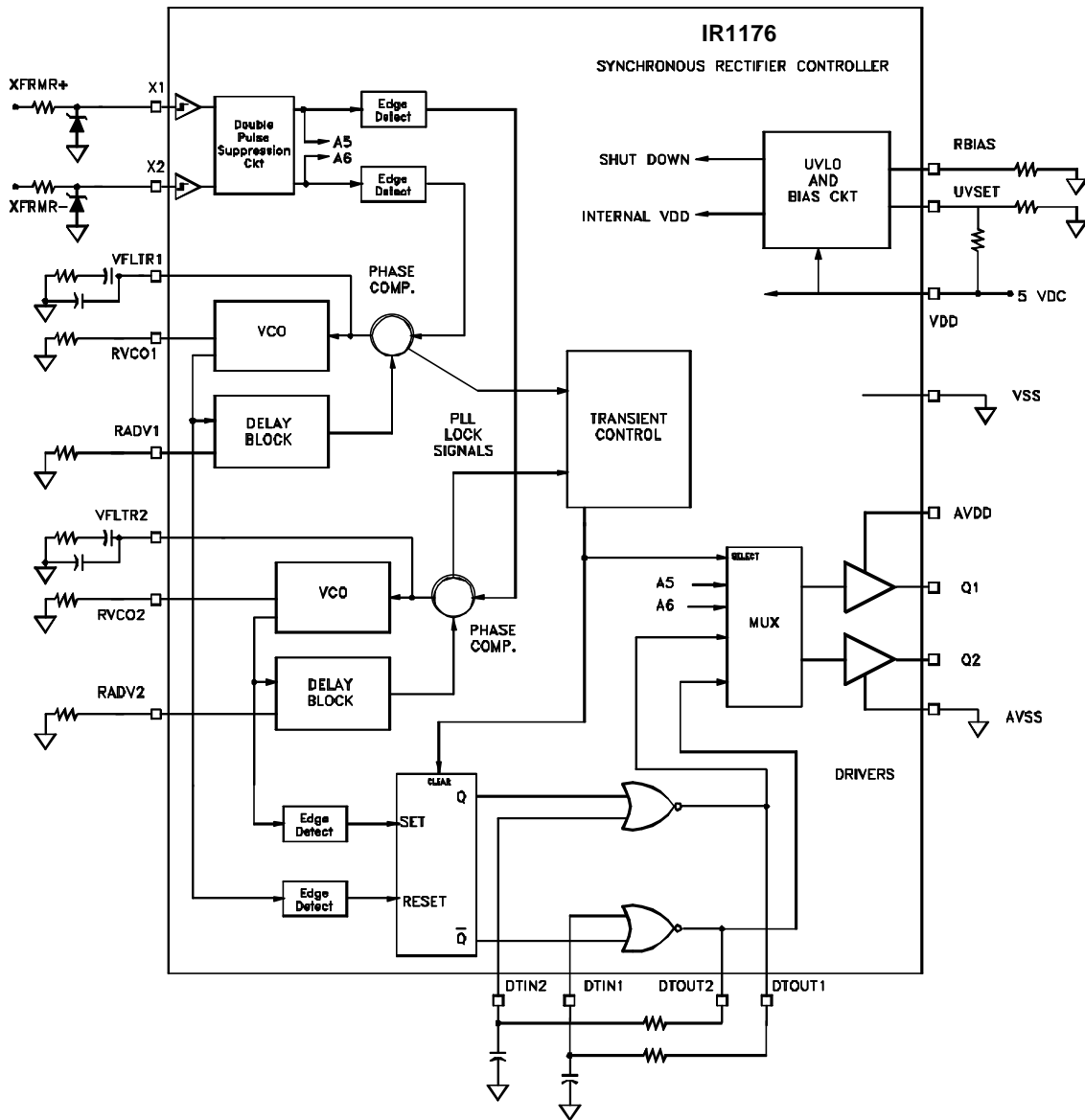
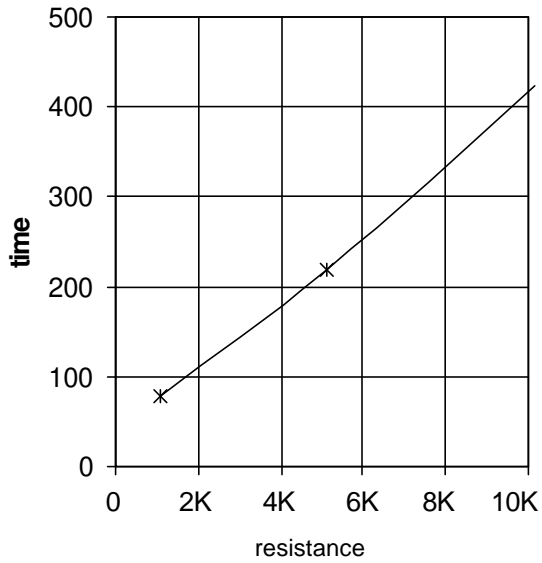
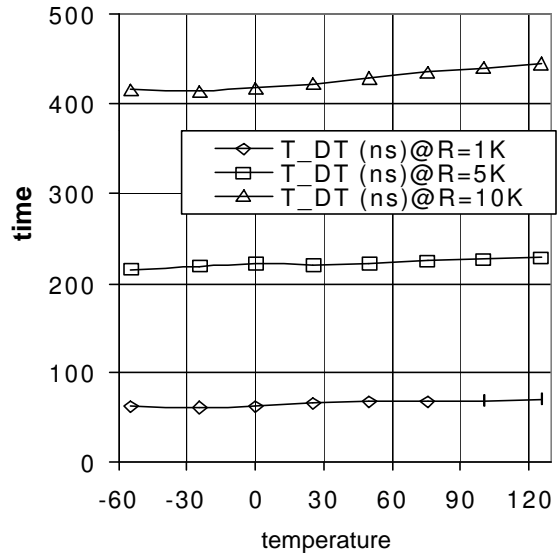

Fig. 5 IR1176 Block Diagram



Response at 25°C
T_{DT} vs R_{DT}, C = 100pF



Temperature Response
T_{DT} vs R_{DT}, C = 100pF

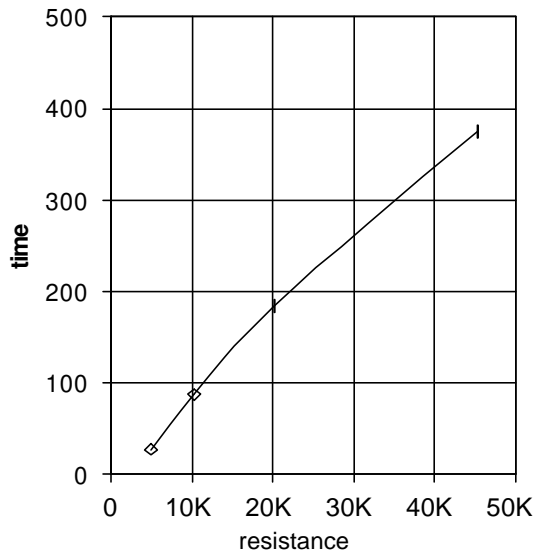

Response at 25°C
T_{ADV} vs R_{ADV}

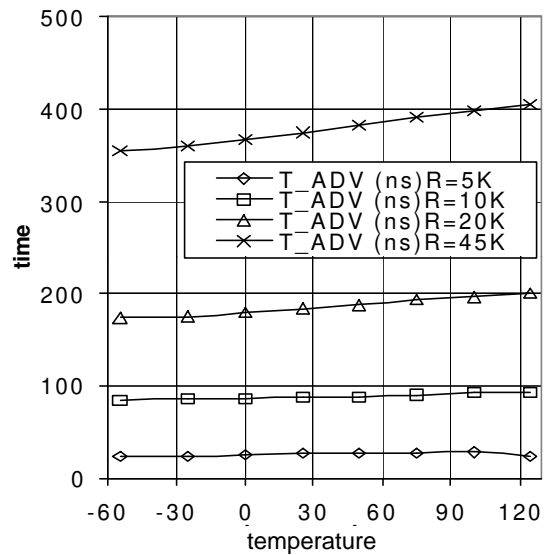

Temperature Response
T_{ADV} vs R_{ADV}

Case Outline

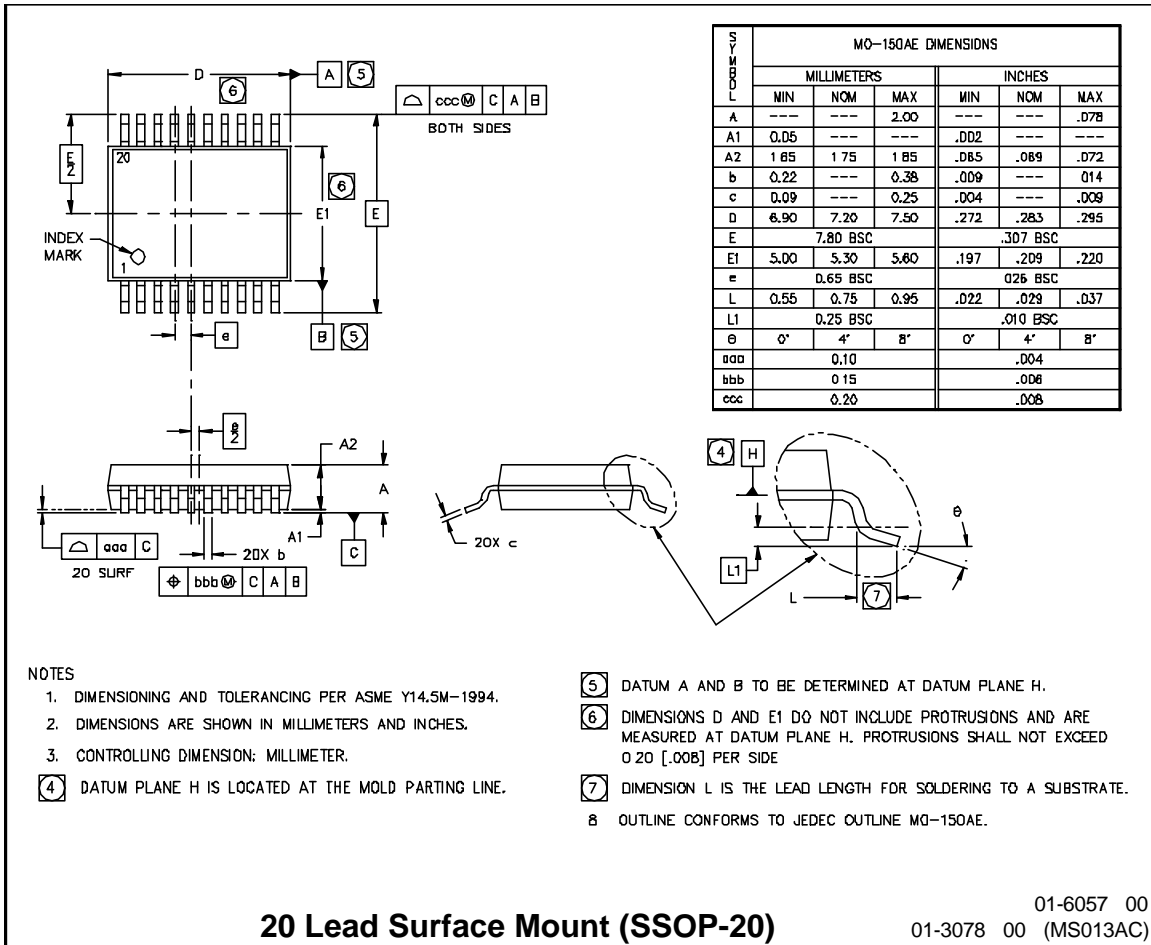

20 Lead Surface Mount (SSOP-20)

01-6057 00
01-3078 00 (MS013AC)

Case Outline

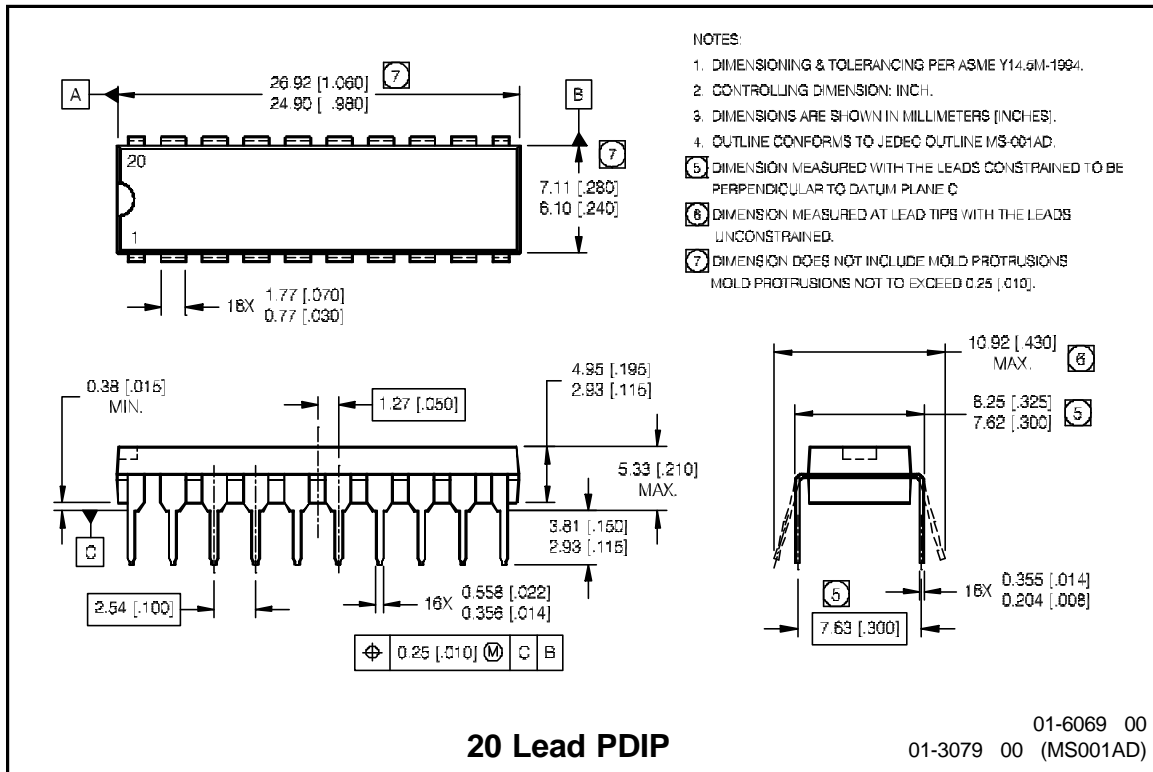

WORLD HEADQUARTERS: 233 Kansas St., El Segundo, California 90245 Tel: (310) 252-7105
Data and specifications subject to change without notice. 1/7/2002