



20DMW4_1.5 Series

20W - Single/Dual Output - Ultra Wide Input - Isolated & Regulated DC-DC Converter

DC-DC Converter

20 Watt

- ⊕ Wide 4:1 input voltage range
- ⊕ High efficiency up to 90%
- ⊕ Remote On/Off
- ⊕ Input/output isolation voltage: 1.5K Vdc
- ⊕ Short circuit protection (SCP)
- ⊕ RoHS compliant
- ⊕ Operating temperature range: -40°C to +85°C
- ⊕ Over voltage protection: clamp mode
- ⊕ Shielded metal case with insulated baseplate
- ⊕ 6 pin DIP package with industry-standard footprint
- ⊕ Standard 1"x1" package
- ⊕ Customer design available



The 20DMW4_1.5 series are isolated 20W DC/DC converters. Designed with high efficiency, they allow the operating temperature range of these units to be -40°C to +85°C (with derating) in a 6 pin DIP package with industry-standard footprint. Further features include wide 4 : 1 input voltage range, remote on/off control, trimmable output, short-circuit protection and over voltage protection.

These converters are well suitable for battery operated equipment, measurement equipment, telecom, wireless network, Industry control system, everywhere where isolated, tightly regulated voltages and compact size are required.

Common specifications

Short circuit protection:	Hiccup, continuous, automatic recovery
Cooling:	Free air convection
Operation temperature range:	-40°C~+85°C
Storage temperature range:	-55°C~+125°C
Maximum case temperature:	100°C MAX
Soldering temperature:	265°C MAX for 10 sec.
Switching frequency:	330kHz TYP
Storage humidity range:	95% MAX
Safety standards:	EN 60950-1, IEC 60950-1
Vibration and thermal shock:	MIL-STD-810E
Case material:	Nickel-coated copper (six-sided)
Base material:	Non-conductive black FR4
Potting material:	Epoxy (UL94V-0)
MTBF (MIL-HDBK-217F @25°C):	340.000 hours
Weight:	16.5g

Isolation specifications

Item	Test condition	Min	Typ	Max	Units
Isolation voltage	Input to output			1500	VDC
Isolation resistance	Test at 500VDC	1000			Ω
Isolation capacitance			1000		pF

Model selection:

WCTV_xxyyN##
W= Watt; **C**=Case; **T**= Type; **V**= Voltage Variation (omitted ± 10%);
xx= Vin; **yy**= Vout; **N**= Numbers of Output; **##**= Isolation (kVDC)

Example:

20DMW4_2415S1.5
20=20Watt; **D**= DIP; **M**=series; **W4**= wide input (4:1) 9-36Vin;
15Vout; **S**=single output; **1.5**=1500VDC

Note:

- Only typical model listed. Non-standard models will be different from the above, please contact us for more details.
- All specifications are measured at TA=25°C, humidity<75%, nominal input voltage and rated output load unless otherwise specified.
- In this datasheet, all the test methods of indications are based on corporate standards.

Input specifications

Item	Test condition	Min	Typ	Max	Units
Input surge voltage (100ms max.)	• Nominal input (24V)		50		VDC
	• Nominal input (48V)		100		
Start-up voltage	• 24V		8.7	9	VDC
	• 48V		16.9	18	VDC
Under voltage shutdown	• 24V		8.3	9	VDC
	• 48V		16.2	18	VDC
Input filter	LC network				
Input reflected ripple current	Nominal Vin and full load		30		mAp-p
Remote ON/OFF	• Converter: ON	3.0 ~ 15			VDC or open circuit
	• Converter: OFF	0 ~ 1.2			VDC or short circuit pin 6 and pin 2
	• Off idle current		2.5		mA
Conducted noise	EN 55022 level A, FCC part 15, level A with external capacitor				
Protection	Fuse recommended				

Output specifications

Item	Test condition	Min	Typ	Max	Units
Voltage tolerance				±2	%
Line regulation	Vmin to Vmax			0.5	%
Load regulation	• 25% load to full load (single)			±0.5	%
	• Balanced load (dual)			±1.0	%
	• Unbalanced load 25% to 100% full load			±5	%
Minimum load	required			10	%
Temperature drift (Vout)				±0.02	%/°C
Ripple and noise*	20MHz Bandwidth			100	mVp-p
Transient response over shoot	di/dt=0.8A/μs			≤ ±5% of Vo (≤ ±6% for 3.3Vout)	
Over load protection	% of full load at nominal input		110		%
Output current limitation	at 150 % of Iout max., constant current				

* Ripple & Noise measurement bandwidth is 20 MHz, measured with a 1uF M/C and a 10uF T/C.

20DMW4_1.5 Series

20W - Single/Dual Output - Ultra Wide Input - Isolated & Regulated DC-DC Converter

Part Number	Input Voltage [VDC]			Output Voltage [VDC]	Output Current [mA]	Input Current [mA]		Efficiency [%, Typ.]	Capacitor load [μ F, Max]
	Nominal	Range	Max			No load	Full load		
20DMW4_2403S1.5	24	9-36	40	3.3	4500	70	719	86	6600
20DMW4_2405S1.5	24	9-36	40	5	4000	70	947	88	6600
20DMW4_2412S1.5	24	9-36	40	12	1670	25	938	89	960
20DMW4_2415S1.5	24	9-36	40	15	1333	25	924	90	470
20DMW4_2412D1.5	24	9-36	40	± 12	± 833	25	936	89	470
20DMW4_2415D1.5	24	9-36	40	± 15	± 667	25	937	89	330
20DMW4_4803S1.5	48	18-75	80	3.3	4500	30	360	96	6600
20DMW4_4805S1.5	48	18-75	80	5	4000	30	473	88	6600
20DMW4_4812S1.5	48	18-75	80	12	1670	15	474	88	330
20DMW4_4815S1.5	48	18-75	80	15	1333	15	472	88	330
20DMW4_4812D1.5	48	18-75	80	± 12	± 833	25	468	89	330
20DMW4_4815D1.5	48	18-75	80	± 15	± 667	25	468	89	220

Add suffix "H" for heatsink mounted, for example 20DMW4_2403S1.5H

Temperature derating curve

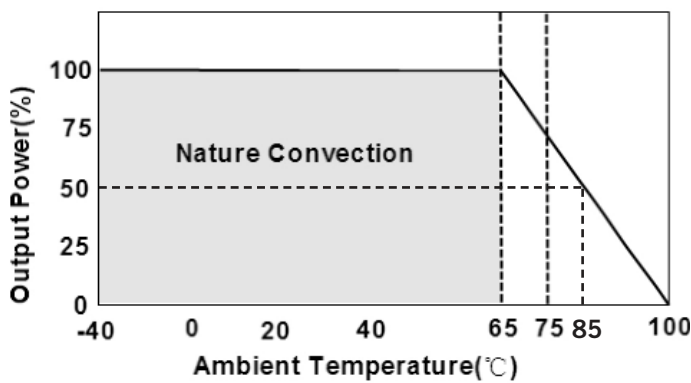

Output voltage adjustment

Control Pin suggest circuit

Output can be externally trimmed by using the method shown below.

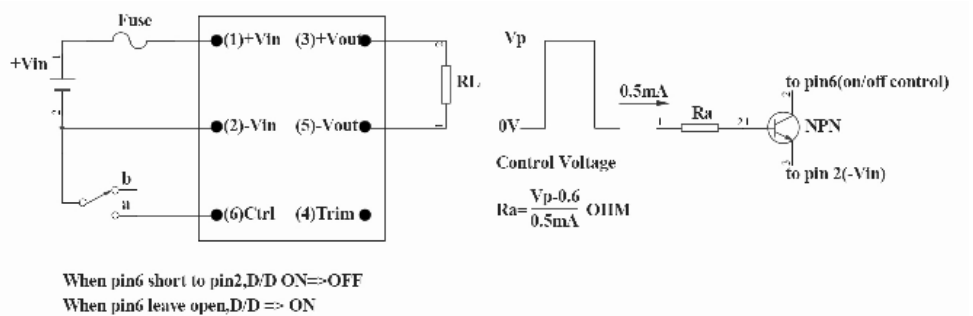
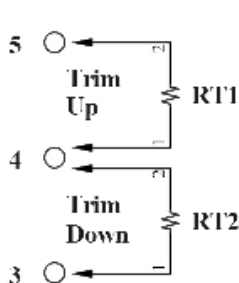

20DMW4_1.5 Series

20W - Single/Dual Output - Ultra Wide Input - Isolated & Regulated DC-DC Converter

EMC considerations

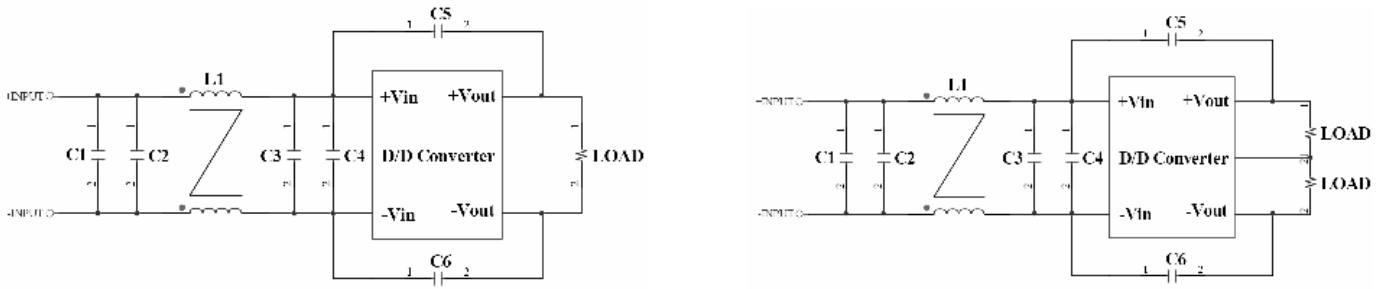

Suggested Schematic to comply with EN55022 Conducted Noise emission Class B

Following components are needed to comply with EN55022 Class B conducted noise:

Component	Value	Voltage	Reference
C2, C3	6.8uF	50V	1812 MLCC
C5, C6	1000pF	2KV	1206 MLCC
L1	325uH		Common Mode Choke

Component	Value	Voltage	Reference
C2, C3, C4	2.2uF	100V	1812 MLCC
C5, C6	1000pF	2KV	1206 MLCC
L1	325uH		Common Mode Choke

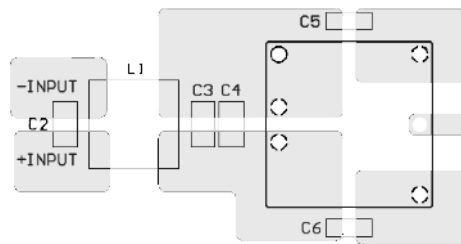

Recommended layout with input filter

Mechanical dimensions

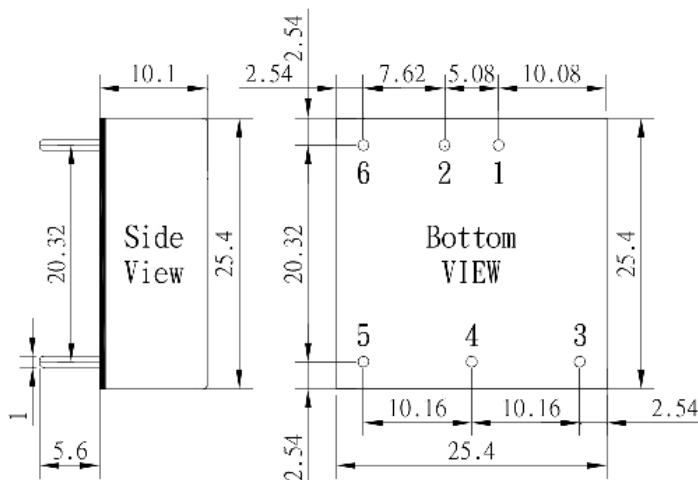

Note:
Unit: mm[inch]
General tolerances: $\pm 0.5\text{mm}$ [$\pm 0.02\text{inch}$]

PIN connection	1	2	3	4	5	6
Single	+Vin	-Vin	+Vout	Trim	-Vout	Ctrl ON/OFF
Dual	+Vin	-Vin	+Vout	Com	-Vout	Ctrl ON/OFF