

P	LTR	DESCRIPTION	DATE	DWN	APVD
	B	REVISED PER ECR-20-012923	21SEP2020	GK	MN

LABEL AND LINER DESIGN

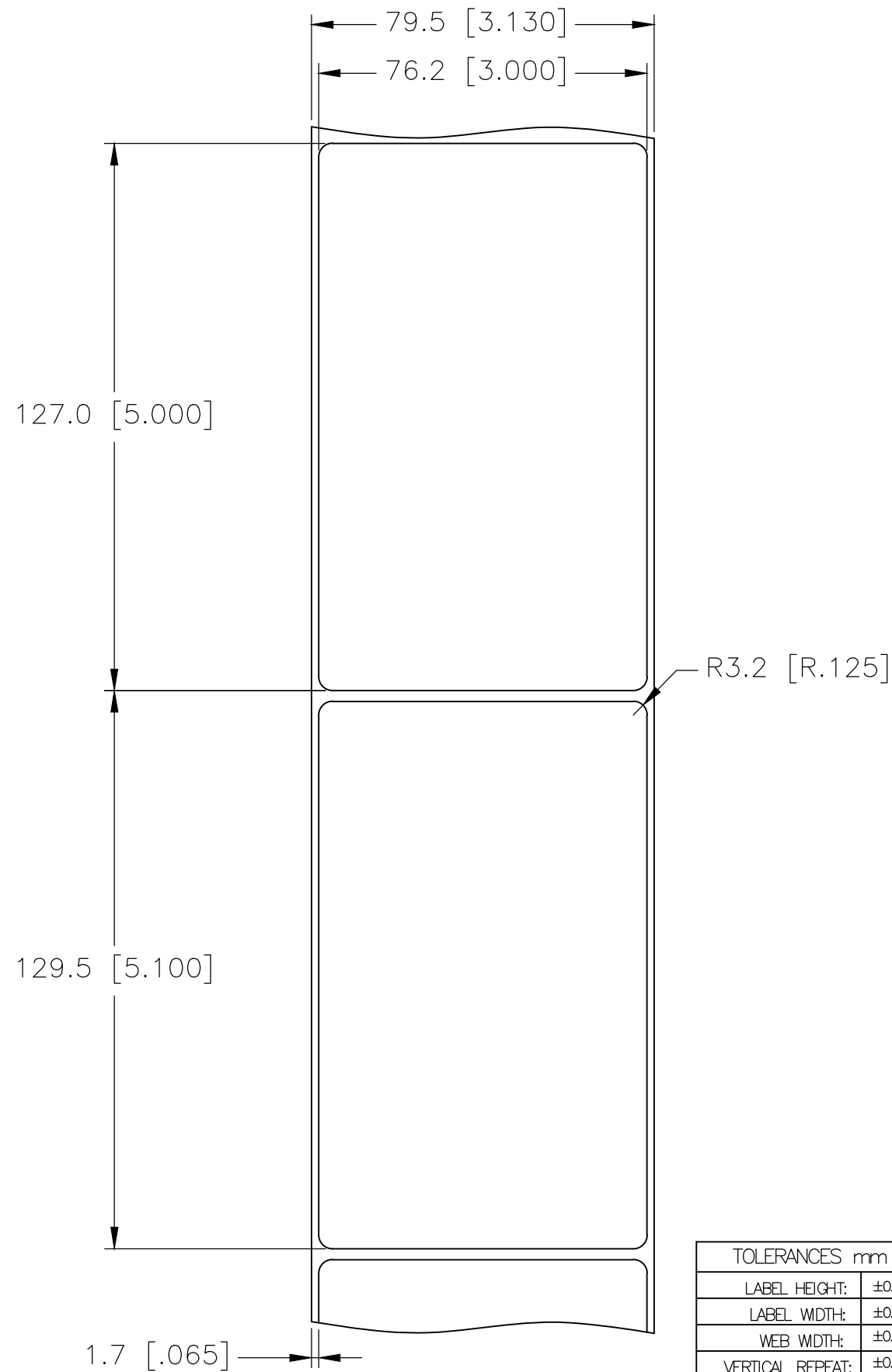

PRESENTATION

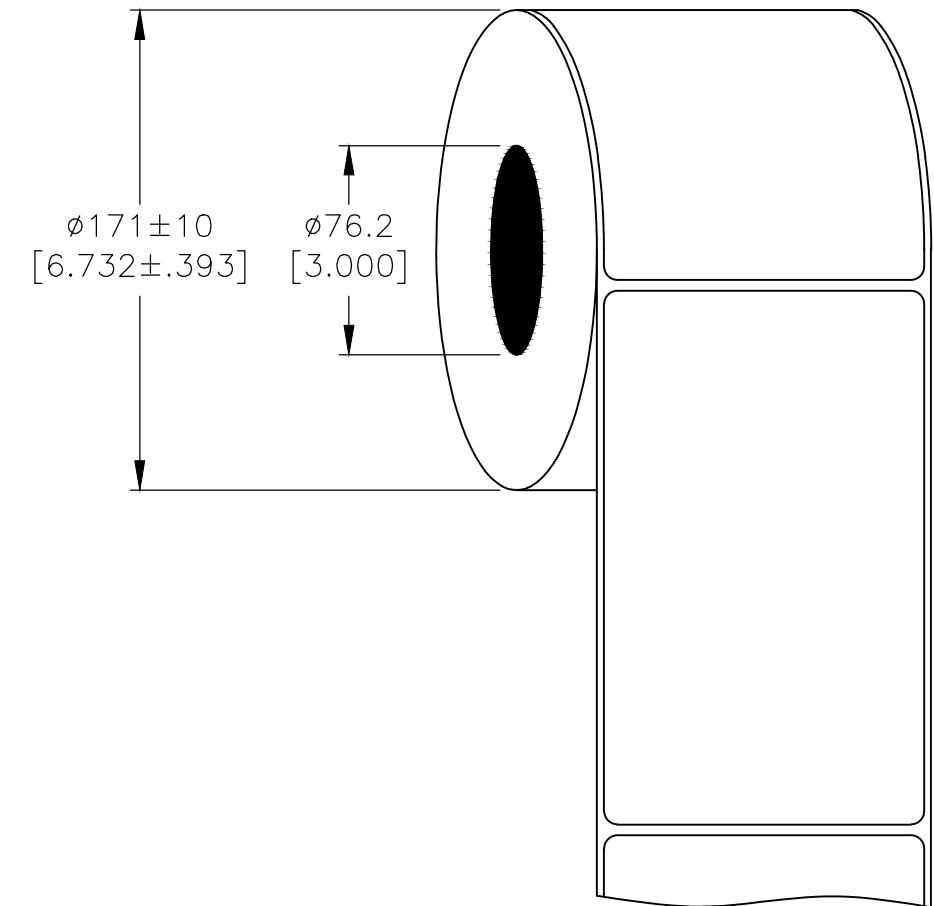

All dimensions in mm [Inches]

TE PN: A83643-000

**OUTSIDE WOUND
LABEL ACROSS: 1
PER ROLL QTY: 1000**

MATERIAL	HIGH TACK METALIZED POLYESTER
ADHESIVE TYPE	PERMANENT ACRYLIC
LINER	GLASSINE PAPER

TOLERANCES mm [INCH]	
LABEL HEIGHT:	± 0.3 [.012]
LABEL WIDTH:	± 0.3 [.012]
WEB WIDTH:	± 0.8 [.031]
VERTICAL REPEAT:	± 0.8 [.031]*
HORIZONTAL REPEAT:	± 0.8 [.031]*
PRINT POSITIONING:	± 0.8 [.031]*
LEFT MARGIN:	± 0.4 [.016]
QUANTITY:	-0 % +2 %
*NON ACCUMULATING	

THIS DRAWING IS A CONTROLLED DOCUMENT.	
DIMENSIONS: mm [INCHES]	TOLERANCES UNLESS OTHERWISE SPECIFIED:
	0 PLC $\pm -$
	1 PLC $\pm -$
	2 PLC $\pm -$
	3 PLC $\pm -$
	4 PLC $\pm -$
ANGLES	$\pm -$
MATERIAL SEE TABLE	FINISH -

DWN	21SEP2020	TE Connectivity	
CHK	21SEP2020		
APVD	21SEP2020		
NAME	MIKE NUTTALL		
PRODUCT SPEC	TTDS-075	HM - HIGH TACK METALIZED POLYESTER LABELS	
APPLICATION SPEC	-	-	
SIZE	CAGE CODE	DRAWING NO	RESTRICTED TO
WEIGHT	1.107g	A3C2290	G=HM-762127-1-8A
CUSTOMER DRAWING		SCALE	SHEET
		NTS	1 OF 1
		REV	B