

FSU SERIES FLOW SWITCHES

FLOW DETECTION SWITCHES



These flow switches are designed for use in liquid flow systems at pressures up to 10 bar and temperatures up to 85°C.

The design is based around a moving magnet and a fixed reed switch with a low flow restriction.

The switches are designed to be used in liquids only and should not be used in systems with significant amounts of solid particles.

Custom versions can be made for particular applications.

Features

- 1/2" and 3/4" NPT thread connections
- 1/2" and 3/4" push fit connections
- Low flow versions available
- Maximum operating pressure 10 bar
- NSF 61 Approved
- Operating temperature rated to 185°F

SPECIFICATIONS

Technical

Material	NSF approved Acetal	
Color	White	
Temp. Range	°C	-20 / +85
	°F	-4 / +185
Cable	10" (25cm) PVC insulated	

Electrical

Contact Form	N/O with no flow	
Switching Power Max	VA	25
Switching Voltage AC Max	V	240
Switching Voltage DC Max	V	120
Switching Current Max	A	0.6

All ratings are resistive load only.

VARIANTS

Threaded

	FSU12A	FSU12LF	FSU34A	FSU34LF	Approvals
*Must Operate US Gal/min (liters/min)	0.53 (2.0)	0.24 (0.9)	0.99 (3.75)	0.47 (1.75)	NSF
#Must Release US Gal/min (liters/min)	0.08 (0.3)	0.07 (0.25)	0.37 (1.4)	0.20 (0.75)	NSF

Push Fit

	FSU50A	FSU50LF	FSU75A	FSU75LF	Approvals
*Must Operate US Gal/min (liters/min)	0.53 (2.0)	0.24 (0.9)	0.99 (3.75)	0.47 (1.75)	NSF
#Must Release US Gal/min (liters/min)	0.08 (0.3)	0.07 (0.25)	0.37 (1.4)	0.20 (0.75)	NSF

* The switch will have operated (contacts closed) when the flow rate rises above this value.

The switch will have released (contacts open) when the flow rate falls below this value.

NB For low flow rate switches the operate and release flow rates only apply when the switch is mounted with the flow direction vertical. The sensitivity of the switch is reduced when mounted with the flow direction horizontal.

INSTALLATION

Flow switches can be mounted with the flow direction horizontal or vertical (upward flow). The cap with cable connection must always be upwards, as the piston is returned to its released position by gravity.

When using metal compression fittings to connect flow switches to copper tube, care must be taken not to over-tighten the fittings onto the flow switch body.

CAUTION!

The use of plastic plumbing fittings may affect the electrical earth continuity bonding as required by IEE regulations. If in doubt, consult a qualified electrician.

DIMENSIONS

All dimensions are in millimeters.

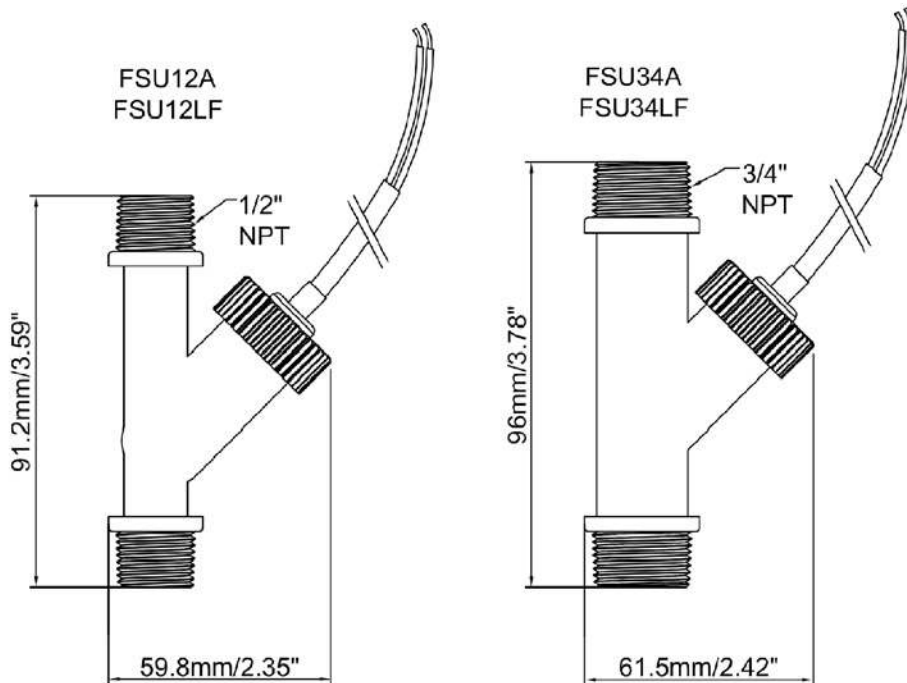

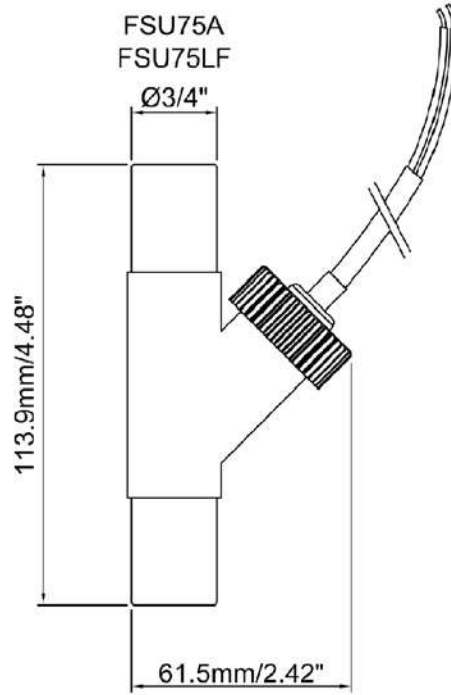
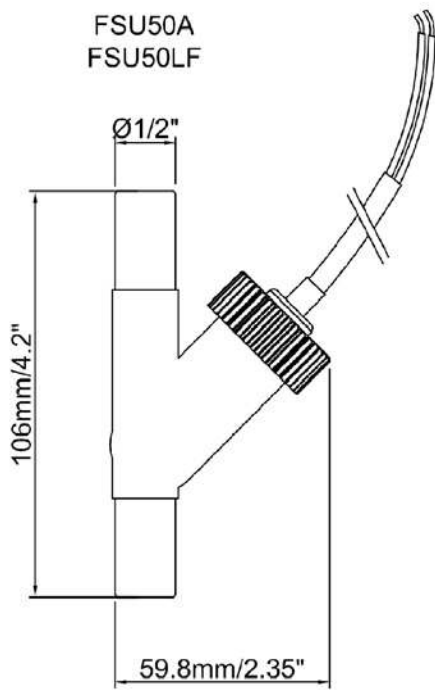

Made in the UK

Page 3

Sensata Technologies, Inc. ("Sensata") data sheets are solely intended to assist designers ("Buyers") who are developing systems that incorporate Sensata products (also referred to herein as "components"). Buyer understands and agrees that Buyer remains responsible for using its independent analysis, evaluation and judgment in designing Buyer's systems and products. Sensata data sheets have been created using standard laboratory conditions and engineering practices. Sensata has not conducted any testing other than that specifically described in the published documentation for a particular data sheet. Sensata may make corrections, enhancements, improvements and other changes to its data sheets or components without notice.

Buyers are authorized to use Sensata data sheets with the Sensata component(s) identified in each particular data sheet. HOWEVER, NO OTHER LICENSE, EXPRESS OR IMPLIED, BY ESTOPPEL OR OTHERWISE TO ANY OTHER SENSATA INTELLECTUAL PROPERTY RIGHT, AND NO LICENSE TO ANY THIRD PARTY TECHNOLOGY OR INTELLECTUAL PROPERTY RIGHT, IS GRANTED HEREIN. SENSATA DATA SHEETS ARE PROVIDED "AS IS". SENSATA MAKES NO WARRANTIES OR REPRESENTATIONS WITH REGARD TO THE DATA SHEETS OR USE OF THE DATA SHEETS, EXPRESS, IMPLIED OR STATUTORY, INCLUDING ACCURACY OR COMPLETENESS. SENSATA DISCLAIMS ANY WARRANTY OF TITLE AND ANY IMPLIED WARRANTIES OF MERCHANTABILITY, FITNESS FOR A PARTICULAR PURPOSE, QUIET ENJOYMENT, QUIET POSSESSION, AND NON-INFRINGEMENT OF ANY THIRD PARTY INTELLECTUAL PROPERTY RIGHTS WITH REGARD TO SENSATA DATA SHEETS OR USE THEREOF.

All products are sold subject to Sensata's terms and conditions of sale supplied at www.sensata.com SENSATA ASSUMES NO LIABILITY FOR APPLICATIONS ASSISTANCE OR THE DESIGN OF BUYERS' PRODUCTS. BUYER ACKNOWLEDGES AND AGREES THAT IT IS SOLELY RESPONSIBLE FOR COMPLIANCE WITH ALL LEGAL, REGULATORY AND SAFETY-RELATED REQUIREMENTS CONCERNING ITS PRODUCTS, AND ANY USE OF SENSATA COMPONENTS IN ITS APPLICATIONS, NOTWITHSTANDING ANY APPLICATIONS-RELATED INFORMATION OR SUPPORT THAT MAY BE PROVIDED BY SENSATA.

Mailing Address: Sensata Technologies, Inc., 529 Pleasant Street, Attleboro, MA 02703, USA.

CONTACT US

+44 (0)1202 897969
 c3w_sales@sensata.com
 Cynergy3 Components Ltd.
 7 Cobham Road,
 Ferndown Industrial Estate,
 Wimborne, Dorset,
 BH21 7PE, United Kingdom