

1/4 ROUND SWAGE STANDOFFS

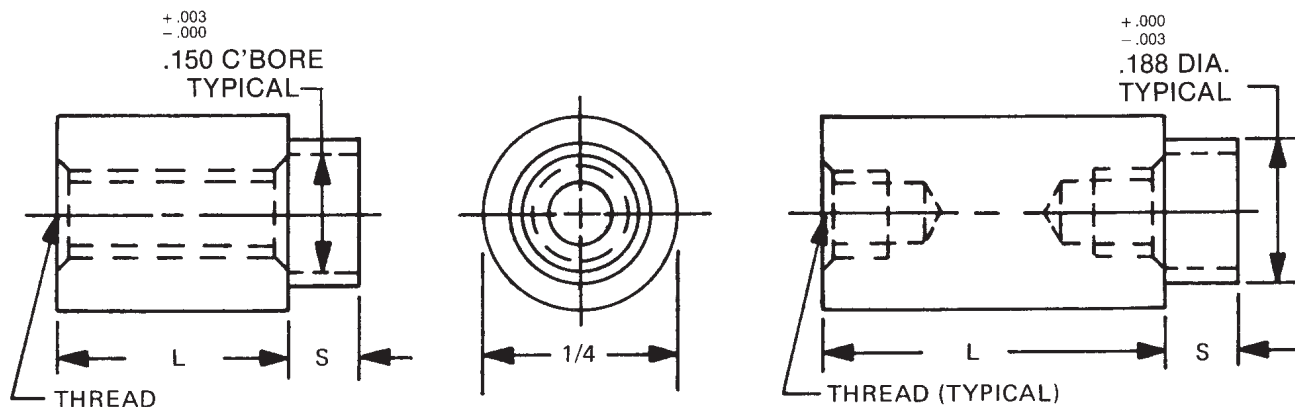

See page iv for installation information

L = STANDOFF LENGTH
 S = SHANK LENGTH
 P = BOARD THICKNESS

See page 10 for thread depth chart
 See page 9 for finish codes
 For non-standard parts contact Sales Office

SWAGE TOOLING		
PUNCH	ANVIL	LENGTH
P-4	AR-22	3/32-3/16
	AR-23	7/32-7/16
	AR-24	15/32-11/16
	AR-25	23/32-2"

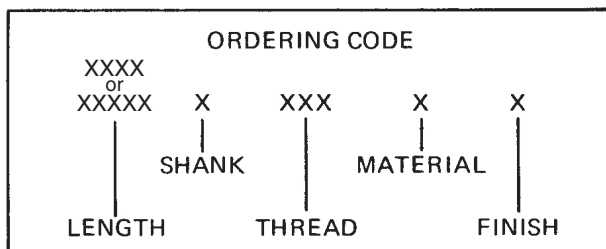

SWAGE/PANEL CODE		
±.003	S	P
.075	A	1/32
.105	B	1/16
.135	C	3/32
.165	D	1/8
.230	E	3/16
.290	F	1/4

LENGTH	PART NO.
3/32	3045A
1/8	3045
5/32	3045T
3/16	3046
7/32	3046T
1/4	3047
9/32	3047T
5/16	3048
11/32	3048T
3/8	3049
13/32	3049T
7/16	3050
15/32	3050T
1/2	3051
17/32	3051T

LENGTH	PART NO.
9/16	3052
19/32	3052T
5/8	3053
21/32	3053T
11/16	3054
23/32	3054T
3/4	3055
25/32	3055T
13/16	3056
27/32	3056T
7/8	3057
29/32	3057T
15/16	3058
31/32	3058T
1"	3059

LENGTH	PART NO.
1-1/16	3060
1-1/8	3061
1-3/16	3062
1-1/4	3063
1-5/16	3064
1-3/8	3065
1-7/16	3066
1-1/2	3067
1-9/16	3068
1-5/8	3069
1-11/16	3070
1-3/4	3071
1-13/16	3072
1-7/8	3073
1-15/16	3074
2"	3075

THREAD	CODE
2-56	256
3-48	348
4-40	440
6-32	632

MATERIAL	CODE	RoHS
Aluminum	AL	YES
Brass	B	YES
Stainless Steel	SS	YES
Steel	S	YES



RAF ELECTRONIC
HARDWARE

95 Silvermine Road, Seymour, Ct. 06483 Phone: 203-888-2133 Fax: 203-888-9860
 e-mail : info@rafhdwe.com Web: www.rafhdwe.com