



power contactor, AC-3e/AC-3, 65 A, 30 kW / 400 V, 3-pole, 175-280 V AC/DC, 50/60 Hz, with integrated varistor, auxiliary contacts: 1 NC, main circuit: screw terminal, control and auxiliary circuit: spring-loaded terminal, size: S2, F-PLC-IN

product brand name	SIRIUS
product designation	Power contactor
product type designation	3RT2
General technical data	
size of contactor	S2
product extension	
• function module for communication	No
• auxiliary switch	Yes
power loss [W] for rated value of the current	
• at AC in hot operating state	11.4 W
• at AC in hot operating state per pole	3.8 W
• without load current share typical	2 W
insulation voltage	
• of main circuit with degree of pollution 3 rated value	690 V
• of auxiliary circuit with degree of pollution 3 rated value	690 V
surge voltage resistance	
• of main circuit rated value	6 kV
• of auxiliary circuit rated value	6 kV
maximum permissible voltage for protective separation between coil and main contacts according to EN 60947-1	400 V
shock resistance at rectangular impulse	
• at AC	7.7g / 5 ms, 4.5g / 10 ms
• at DC	7.7g / 5 ms, 4.5g / 10 ms
shock resistance with sine pulse	
• at AC	12g / 5 ms, 7g / 10 ms
• at DC	12g / 5 ms, 7g / 10 ms
mechanical service life (operating cycles)	
• of contactor typical	5 000 000
• of the contactor with added electronically optimized auxiliary switch block typical	5 000 000
• of the contactor with added auxiliary switch block typical	5 000 000
reference code according to IEC 81346-2	Q
Substance Prohibitance (Date)	01/29/2021
Ambient conditions	
installation altitude at height above sea level maximum	2 000 m
ambient temperature	
• during operation	-25 ... +60 °C
• during storage	-55 ... +80 °C
relative humidity minimum	10 %
relative humidity at 55 °C according to IEC 60068-2-30 maximum	95 %

Main circuit

number of poles for main current circuit	3
number of NO contacts for main contacts	3
operating voltage	
• at AC-3 rated value maximum	690 V
• at AC-3e rated value maximum	690 V
operational current	
• at AC-1 at 400 V at ambient temperature 40 °C rated value	80 A
• at AC-1	
— up to 690 V at ambient temperature 40 °C rated value	80 A
— up to 690 V at ambient temperature 60 °C rated value	70 A
• at AC-3	
— at 400 V rated value	65 A
— at 500 V rated value	65 A
— at 690 V rated value	47 A
• at AC-3e	
— at 400 V rated value	65 A
— at 500 V rated value	65 A
— at 690 V rated value	47 A
• at AC-4 at 400 V rated value	55 A
• at AC-5a up to 690 V rated value	70.4 A
• at AC-5b up to 400 V rated value	53.9 A
• at AC-6a	
— up to 230 V for current peak value n=20 rated value	56.9 A
— up to 400 V for current peak value n=20 rated value	56.9 A
— up to 500 V for current peak value n=20 rated value	56.9 A
— up to 690 V for current peak value n=20 rated value	47 A
• at AC-6a	
— up to 230 V for current peak value n=30 rated value	38 A
— up to 400 V for current peak value n=30 rated value	38 A
— up to 500 V for current peak value n=30 rated value	38 A
— up to 690 V for current peak value n=30 rated value	38 A
minimum cross-section in main circuit at maximum AC-1 rated value	25 mm ²
operational current for approx. 200000 operating cycles at AC-4	
• at 400 V rated value	28 A
• at 690 V rated value	22 A
operational current	
• at 1 current path at DC-1	
— at 24 V rated value	55 A
— at 60 V rated value	23 A
— at 110 V rated value	4.5 A
— at 220 V rated value	1 A
— at 440 V rated value	0.4 A
— at 600 V rated value	0.25 A
• with 2 current paths in series at DC-1	
— at 24 V rated value	55 A
— at 60 V rated value	45 A
— at 110 V rated value	45 A
— at 220 V rated value	5 A
— at 440 V rated value	1 A
— at 600 V rated value	0.8 A
• with 3 current paths in series at DC-1	
— at 24 V rated value	55 A
— at 60 V rated value	55 A
— at 110 V rated value	55 A
— at 220 V rated value	45 A
— at 440 V rated value	2.9 A

<ul style="list-style-type: none"> — at 600 V rated value 	1.4 A
<ul style="list-style-type: none"> ● at 1 current path at DC-3 at DC-5 <ul style="list-style-type: none"> — at 24 V rated value — at 60 V rated value — at 220 V rated value — at 440 V rated value — at 600 V rated value ● with 2 current paths in series at DC-3 at DC-5 <ul style="list-style-type: none"> — at 24 V rated value — at 60 V rated value — at 110 V rated value — at 220 V rated value — at 440 V rated value — at 600 V rated value ● with 3 current paths in series at DC-3 at DC-5 <ul style="list-style-type: none"> — at 24 V rated value — at 60 V rated value — at 110 V rated value — at 220 V rated value — at 440 V rated value — at 600 V rated value 	35 A 6 A 1 A 0.1 A 0.06 A 55 A 45 A 25 A 5 A 0.27 A 0.16 A 55 A 55 A 55 A 25 A 0.6 A 0.35 A
operating power <ul style="list-style-type: none"> ● at AC-2 at 400 V rated value ● at AC-3 <ul style="list-style-type: none"> — at 230 V rated value — at 400 V rated value — at 500 V rated value — at 690 V rated value ● at AC-3e <ul style="list-style-type: none"> — at 230 V rated value — at 400 V rated value — at 500 V rated value — at 690 V rated value 	30 kW 18.5 kW 30 kW 37 kW 37 kW 18.5 kW 30 kW 37 kW 37 kW
operating power for approx. 200000 operating cycles at AC-4 <ul style="list-style-type: none"> ● at 400 V rated value ● at 690 V rated value 	14.7 kW 20 kW
operating apparent power at AC-6a <ul style="list-style-type: none"> ● up to 400 V for current peak value n=20 rated value ● up to 500 V for current peak value n=20 rated value ● up to 690 V for current peak value n=20 rated value 	39 400 VA 49 200 VA 56 100 VA
operating apparent power at AC-6a <ul style="list-style-type: none"> ● up to 230 V for current peak value n=30 rated value ● up to 400 V for current peak value n=30 rated value ● up to 500 V for current peak value n=30 rated value ● up to 690 V for current peak value n=30 rated value 	15 100 VA 26 200 VA 32 800 VA 45 300 VA
short-time withstand current in cold operating state up to 40 °C <ul style="list-style-type: none"> ● limited to 1 s switching at zero current maximum ● limited to 5 s switching at zero current maximum ● limited to 10 s switching at zero current maximum ● limited to 30 s switching at zero current maximum ● limited to 60 s switching at zero current maximum 	1 055 A; Use minimum cross-section acc. to AC-1 rated value 730 A; Use minimum cross-section acc. to AC-1 rated value 520 A; Use minimum cross-section acc. to AC-1 rated value 336 A; Use minimum cross-section acc. to AC-1 rated value 272 A; Use minimum cross-section acc. to AC-1 rated value
no-load switching frequency <ul style="list-style-type: none"> ● at AC ● at DC 	1 000 1/h 1 000 1/h
operating frequency <ul style="list-style-type: none"> ● at AC-1 maximum ● at AC-2 maximum ● at AC-3 maximum ● at AC-3e maximum 	800 1/h 400 1/h 700 1/h 700 1/h

• at AC-4 maximum	200 1/h
Control circuit/ Control	
type of voltage of the control supply voltage	AC/DC
control supply voltage at AC	
• at 50 Hz rated value	175 ... 280 V
• at 60 Hz rated value	175 ... 280 V
control supply voltage at DC	
• rated value	175 ... 280 V
operating range factor control supply voltage rated value of magnet coil at DC	
• initial value	0.8
• full-scale value	1.1
operating range factor control supply voltage rated value of magnet coil at AC	
• at 50 Hz	0.8 ... 1.1
• at 60 Hz	0.8 ... 1.1
type of PLC-control input according to IEC 60947-1	Type 1
consumed current at PLC-control input according to IEC 60947-1 maximum	11 mA
voltage at PLC-control input rated value	24 V
operating range factor of the voltage at PLC-control input	0.8 ... 1.1
design of the surge suppressor	with varistor
inrush current peak	43 A
duration of inrush current peak	10 µs
locked-rotor current mean value	0.18 A
locked-rotor current peak	0.42 A
duration of locked-rotor current	230 ms
holding current mean value	0.01 A
apparent pick-up power of magnet coil at AC	
• at 50 Hz	40 VA
• at 60 Hz	40 VA
apparent holding power of magnet coil at AC	
• at 50 Hz	2 VA
• at 60 Hz	2 VA
closing power of magnet coil at DC	40 W
holding power of magnet coil at DC	1.6 W
closing delay	
• at AC	35 ... 110 ms
• at DC	35 ... 110 ms
opening delay	
• at AC	30 ... 55 ms
• at DC	30 ... 55 ms
recovery time after power failure typical	2.1 s
arcing time	10 ... 20 ms
control version of the switch operating mechanism	Fail-safe PLC input (F-PLC-IN)
Auxiliary circuit	
number of NC contacts for auxiliary contacts instantaneous contact	1
number of NO contacts for auxiliary contacts instantaneous contact	0
operational current at AC-12 maximum	10 A
operational current at AC-15	
• at 230 V rated value	10 A
• at 400 V rated value	3 A
• at 500 V rated value	2 A
• at 690 V rated value	1 A
operational current at DC-12	
• at 24 V rated value	10 A
• at 48 V rated value	6 A
• at 60 V rated value	6 A
• at 110 V rated value	3 A
• at 125 V rated value	2 A

<ul style="list-style-type: none"> • at 220 V rated value • at 600 V rated value 	<p>1 A</p> <p>0.15 A</p>
operational current at DC-13 <ul style="list-style-type: none"> • at 24 V rated value • at 48 V rated value • at 60 V rated value • at 110 V rated value • at 125 V rated value • at 220 V rated value • at 600 V rated value 	<p>10 A</p> <p>2 A</p> <p>2 A</p> <p>1 A</p> <p>0.9 A</p> <p>0.3 A</p> <p>0.1 A</p>
contact reliability of auxiliary contacts	<p>1 faulty switching per 100 million (17 V, 1 mA)</p>
UL/CSA ratings	
full-load current (FLA) for 3-phase AC motor <ul style="list-style-type: none"> • at 480 V rated value • at 600 V rated value 	<p>65 A</p> <p>52 A</p>
yielded mechanical performance [hp] <ul style="list-style-type: none"> • for single-phase AC motor <ul style="list-style-type: none"> — at 110/120 V rated value — at 230 V rated value • for 3-phase AC motor <ul style="list-style-type: none"> — at 200/208 V rated value — at 220/230 V rated value — at 460/480 V rated value — at 575/600 V rated value 	<p>5 hp</p> <p>10 hp</p> <p>20 hp</p> <p>20 hp</p> <p>50 hp</p> <p>50 hp</p>
contact rating of auxiliary contacts according to UL	<p>A600 / P600</p>
Short-circuit protection	
design of the fuse link <ul style="list-style-type: none"> • for short-circuit protection of the main circuit <ul style="list-style-type: none"> — with type of coordination 1 required — with type of assignment 2 required • for short-circuit protection of the auxiliary switch required 	<p>gG: 250 A (690 V, 100 kA), aM: 160 A (690 V, 100 kA), BS88: 200 A (415 V, 80 kA)</p> <p>gG: 125A (690V,100kA), aM: 63A (690V,100kA), BS88: 100A (415V,80kA)</p> <p>gG: 10 A (500 V, 1 kA)</p>
Installation/ mounting/ dimensions	
mounting position	<p>+/-180° rotation possible on vertical mounting surface; can be tilted forward and backward by +/- 22.5° on vertical mounting surface</p>
fastening method <ul style="list-style-type: none"> • side-by-side mounting 	<p>screw and snap-on mounting onto 35 mm DIN rail according to DIN EN 60715</p> <p>Yes</p>
height	<p>114 mm</p>
width	<p>55 mm</p>
depth	<p>130 mm</p>
required spacing <ul style="list-style-type: none"> • with side-by-side mounting <ul style="list-style-type: none"> — forwards — upwards — downwards — at the side • for grounded parts <ul style="list-style-type: none"> — forwards — upwards — at the side — downwards • for live parts <ul style="list-style-type: none"> — forwards — upwards — downwards — at the side 	<p>10 mm</p> <p>10 mm</p> <p>10 mm</p> <p>0 mm</p> <p>10 mm</p> <p>10 mm</p> <p>6 mm</p> <p>10 mm</p> <p>10 mm</p> <p>10 mm</p> <p>6 mm</p>
Connections/ Terminals	
type of electrical connection <ul style="list-style-type: none"> • for main current circuit • for auxiliary and control circuit • at contactor for auxiliary contacts 	<p>screw-type terminals</p> <p>spring-loaded terminals</p> <p>Spring-type terminals</p>

• of magnet coil	Spring-type terminals
type of connectable conductor cross-sections for main contacts	
• solid or stranded	2x (1 ... 35 mm ²), 1x (1 ... 50 mm ²)
• finely stranded with core end processing	2x (1 ... 25 mm ²), 1x (1 ... 35 mm ²)
connectable conductor cross-section for main contacts	
• finely stranded with core end processing	1 ... 35 mm ²
connectable conductor cross-section for auxiliary contacts	
• solid or stranded	0.5 ... 2.5 mm ²
• finely stranded with core end processing	0.5 ... 1.5 mm ²
• finely stranded without core end processing	0.5 ... 2.5 mm ²
type of connectable conductor cross-sections	
• for auxiliary contacts	
— solid or stranded	2x (0.5 ... 2.5 mm ²)
— finely stranded with core end processing	2x (0.5 ... 1.5 mm ²)
— finely stranded without core end processing	2x (0.5 ... 2.5 mm ²)
• for AWG cables for auxiliary contacts	2x (20 ... 14)
AWG number as coded connectable conductor cross section	
• for main contacts	18 ... 1
• for auxiliary contacts	20 ... 14

Safety related data

product function	
• mirror contact according to IEC 60947-4-1	Yes
• positively driven operation according to IEC 60947-5-1	No
safety device type according to IEC 61508-2	Type B
B10 value with high demand rate according to SN 31920	1 000 000
Safety Integrity Level (SIL) according to IEC 61508	2
SIL Claim Limit (subsystem) according to EN 62061	2
performance level (PL) according to EN ISO 13849-1	c
category according to EN ISO 13849-1	2
stop category according to EN 60204-1	0
Safe failure fraction (SFF)	96 %
diagnostics test interval by internal test function maximum	28 800 s
proportion of dangerous failures	
• with low demand rate according to SN 31920	40 %
• with high demand rate according to SN 31920	73 %
failure rate [FIT] with low demand rate according to SN 31920	100 FIT
PFHD with high demand rate according to EN 62061	7.7E-8 1/h
PFDavg with low demand rate according to IEC 61508	0.0067
MTBF	52 a
hardware fault tolerance according to IEC 61508	0
T1 value for proof test interval or service life according to IEC 61508	20 a
protection class IP on the front according to IEC 60529	IP20
touch protection on the front according to IEC 60529	finger-safe, for vertical contact from the front

Certificates/ approvals

General Product Approval



[Confirmation](#)



[KC](#)



EMC	Functional Safety/Safety of Machinery	Declaration of Conformity	Test Certificates	Marine / Shipping
-----	---------------------------------------	---------------------------	-------------------	-------------------



[Type Examination Certificate](#)



EG-Konf.

[Type Test Certificates/Test Report](#)



[Confirmation](#)
[Vibration and Shock](#)

Further information

Siemens has decided to exit the Russian market (see here).

<https://press.siemens.com/global/en/pressrelease/siemens-wind-down-russian-business>

Siemens is working on the renewal of the current EAC certificates.

Please contact your local Siemens office on the status of validity of the EAC certification if you intend to import or offer to supply these products to an EAC relevant market (other than the sanctioned EAEU member states Russia or Belarus).

Information on the packaging

<https://support.industry.siemens.com/cs/ww/en/view/109813875>

Information- and Downloadcenter (Catalogs, Brochures,...)

<https://www.siemens.com/ic10>

Industry Mall (Online ordering system)

<https://mall.industry.siemens.com/mall/en/en/Catalog/product?mlfb=3RT2037-3SP30>

Cax online generator

<http://support.automation.siemens.com/WW/CAXorder/default.aspx?lang=en&mlfb=3RT2037-3SP30>

Service&Support (Manuals, Certificates, Characteristics, FAQs,...)

<https://support.industry.siemens.com/cs/ww/en/ps/3RT2037-3SP30>

Image database (product images, 2D dimension drawings, 3D models, device circuit diagrams, EPLAN macros, ...)

http://www.automation.siemens.com/bilddb/cax_de.aspx?mlfb=3RT2037-3SP30&lang=en

Characteristic: Tripping characteristics, I²t, Let-through current

<https://support.industry.siemens.com/cs/ww/en/ps/3RT2037-3SP30/char>

Further characteristics (e.g. electrical endurance, switching frequency)

<http://www.automation.siemens.com/bilddb/index.aspx?view=Search&mlfb=3RT2037-3SP30&objecttype=14&gridview=view1>

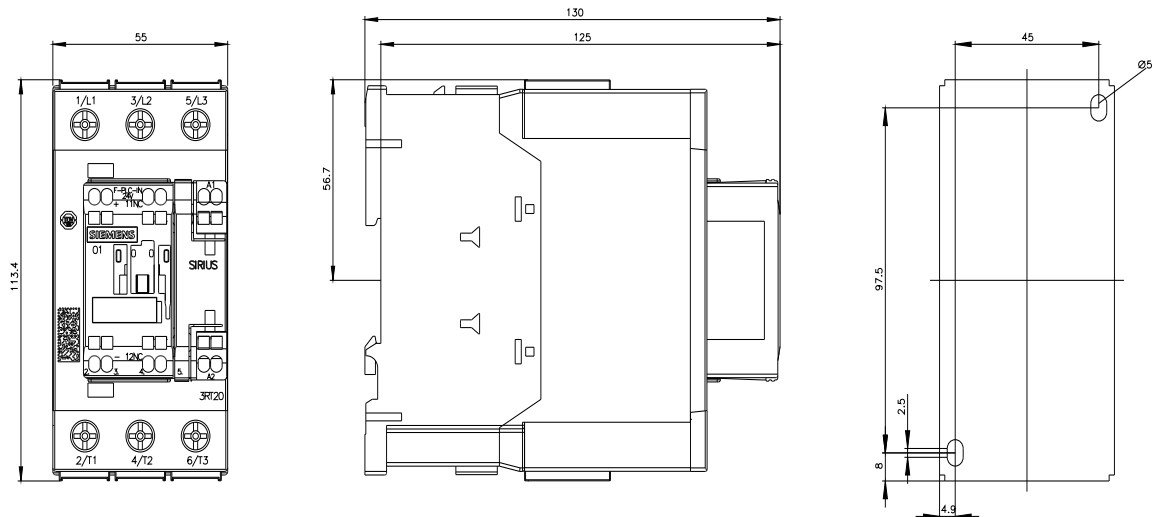

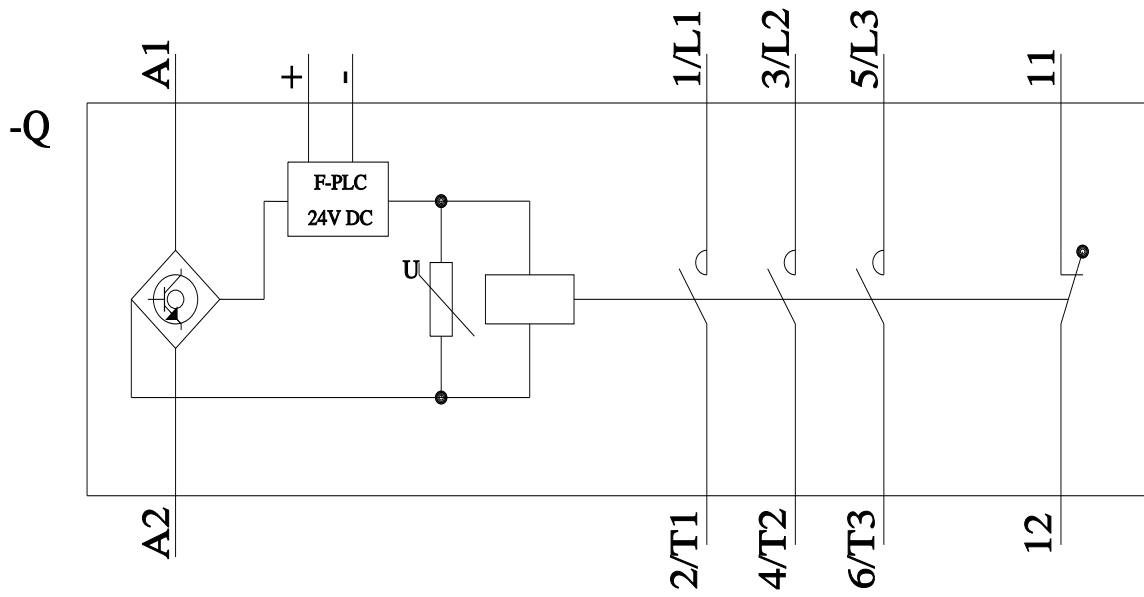

last modified:

2/10/2023 