

DATE	REV	ECN	APP'D. BY
1-13-15	A5	10187	TRM
3-8-16	A6	10593	TRM
3-27-17	A7	10940	TRM

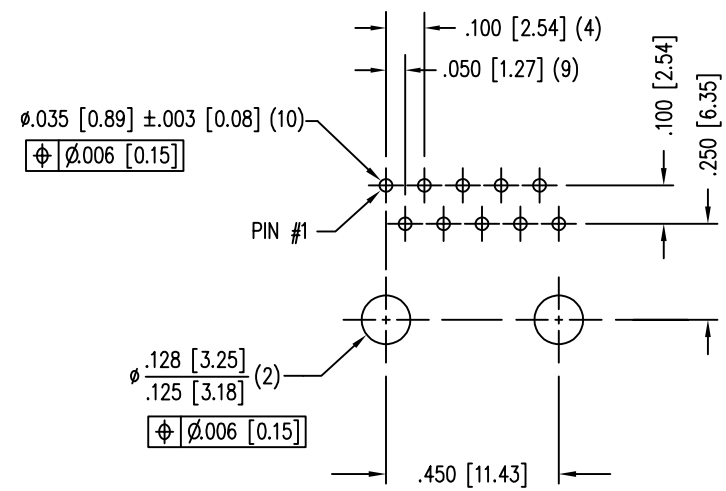
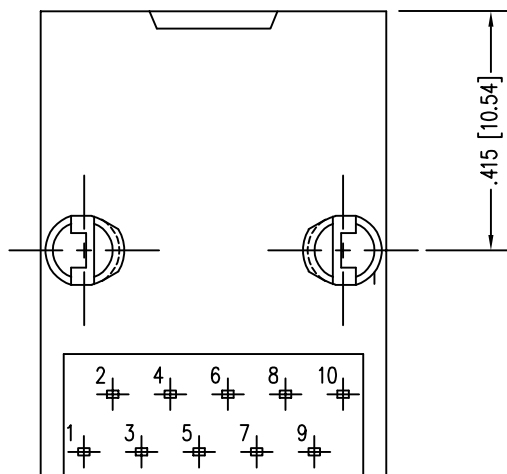
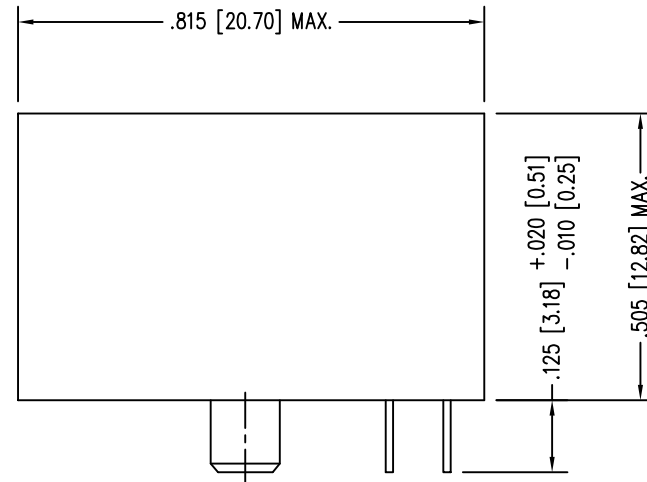
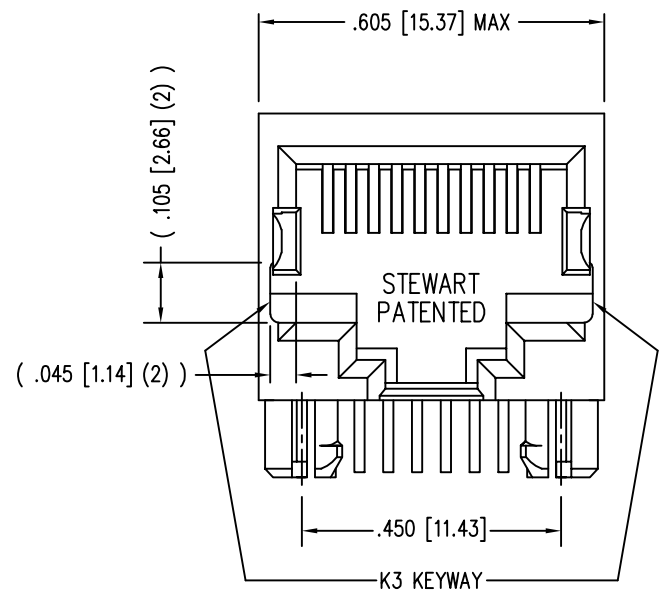

P.C.B. RECOMMENDED HOLE LAYOUT
SEEN FROM COMPONENT SIDE
ALL CENTERLINE DIMENSIONS ARE BASIC.

- NOTES:
- CONNECTOR MATERIALS:
HOUSING: THERMOPLASTIC UL94 V-0
CONTACTS: COPPER ALLOY
CONTACT PLATING: SELECTIVE GOLD IN CONTACT AREA
SEE CHART FOR PART NUMBER
 - FOR PRODUCT SPECIFICATION SEE PRO22-01
 - DIMENSIONS AND TOLERANCES COMPLY WITH TIA-1096 STANDARD.

30 MICRO-INCHES [0.76um]	SS64100-034F
CONTACT PLATING IN MATING AREA	PART NUMBER

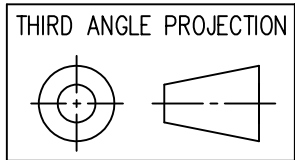

stewart
CONNECTOR
a bel group

11118 Susquehanna Trail South
Glen Rock, PA 17327-9199
(717) 235-7512
<http://www.stewartconnector.com>

DO NOT SCALE DRAWING DRAWING IS SUBJECT TO CHANGE WITHOUT NOTICE	TITLE: TEN CONTACT, TEN POSITION, UNSHIELDED JACK NON-FLANGED, K3 KEYING OPTION & R.O.H.S. COMPLIANT	
DIMENSIONS: INCHES [METRIC]	DRN BY: TRM	DATE: 11/09/04
UNLESS OTHERWISE SPECIFIED TOLERANCES ARE ±.005 [0.13] ANGLES ARE ± 1°	APPD BY: RGC	DATE: 11/09/04
SHEET NO. 1 OF 1	DWG NO. CT640074F	REV. A7

