

FEATURES

- 10- and 12-bit ADC with fast conversion time: 2 μ s typ**
- 8 single-ended analog input channels**
- Specified for V_{DD} of 2.7 V to 5.5 V**
- Low power consumption**
- Fast throughput rate: up to 188 kSPS**
- Sequencer operation**
- Automatic cycle mode**
- I²C[®]-compatible serial interface supports standard, fast, and high speed modes**
- Out-of-range indicator/alert function**
- Pin-selectable addressing via AS**
- Shutdown mode: 1 μ A max**
- Temperature range: -40°C to +85°C**
- 20-lead TSSOP package**
- See the AD7992 and AD7994 for 2-channel and 4-channel equivalent devices, respectively**

GENERAL DESCRIPTION

The AD7997/AD7998 are 8-channel, 10- and 12-bit, low power, successive approximation ADCs with an I²C-compatible interface. The parts operate from a single 2.7 V to 5.5 V power supply and feature a 2 μ s conversion time. The parts contain an 8-channel multiplexer and track-and-hold amplifier that can handle input frequencies up to 11 MHz.

The AD7997/AD7998 provide a 2-wire serial interface that is compatible with I²C interfaces. Each part comes in two versions, AD7997-0/AD7998-0 and AD7997-1/AD7998-1, and each version allows at least two different I²C addresses. The I²C interface on the AD7997-0/AD7998-0 supports standard and fast I²C interface modes. The I²C interface on the AD7997-1/AD7998-1 supports standard, fast, and high speed I²C interface modes.

The AD7997/AD7998 normally remain in a shutdown state while not converting, and power up only for conversions. The conversion process can be controlled using the $\overline{\text{CONVST}}$ pin, by a command mode where conversions occur across I²C write operations or an automatic conversion interval mode selected through software control.

The AD7997/AD7998 require an external reference that should be applied to the REF_{IN} pin and can be in the range of 1.2 V to V_{DD} . This allows the widest dynamic input range to the ADC.

Rev. 0

Information furnished by Analog Devices is believed to be accurate and reliable. However, no responsibility is assumed by Analog Devices for its use, nor for any infringements of patents or other rights of third parties that may result from its use. Specifications subject to change without notice. No license is granted by implication or otherwise under any patent or patent rights of Analog Devices. Trademarks and registered trademarks are the property of their respective owners.

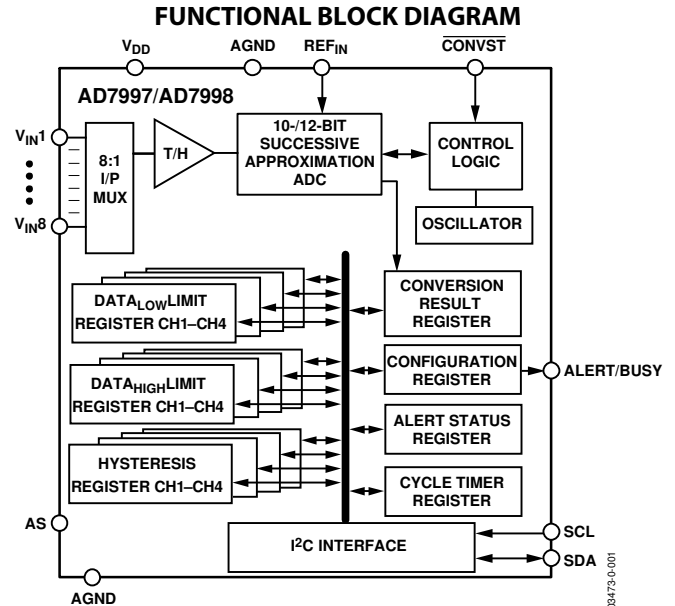

Figure 1.

On-chip limit registers can be programmed with high and low limits for the conversion result, and an open-drain, out-of-range indicator output (ALERT) becomes active when the programmed high or low limits are violated by the conversion result. This output can be used as an interrupt.

PRODUCT HIGHLIGHTS

1. 2 μ s conversion time with low power consumption.
2. I²C-compatible serial interface with pin-selectable addresses. Two AD7997/AD7998 versions allow five AD7997/AD7998 devices to be connected to the same serial bus.
3. The parts feature automatic shutdown while not converting to maximize power efficiency. Current consumption is 1 μ A max when in shutdown mode at 3V.
4. Reference can be driven up to the power supply.
5. Out-of-range indicator that can be software disabled or enabled.
6. One-shot and automatic conversion rates.
7. Registers store minimum and maximum conversion results.

TABLE OF CONTENTS

AD7997 Specifications.....	3	Serial Bus Address.....	23
AD7998 Specifications.....	5	Writing to the AD7997/AD7998.....	24
I ² C Timing Specifications.....	7	Writing to the Address Pointer Register for a Subsequent Read.....	24
Absolute Maximum Ratings.....	9	Writing a Single Byte of Data to the Alert Status Register or Cycle Register.....	24
ESD Caution.....	9	Writing Two Bytes of Data to a Limit, Hysteresis, or Configuration Register.....	24
Pin Configuration and Pin Function Descriptions.....	10	Reading Data from the AD7997/AD7998.....	26
Terminology.....	11	ALERT/BUSY Pin.....	27
Typical Performance Characteristics.....	12	SMBus ALERT.....	27
Circuit Information.....	15	BUSY.....	27
Converter Operation.....	15	Placing the AD7997-1/AD7998-1 into High Speed Mode ...	27
Typical Connection Diagram.....	16	The Address Select (AS) Pin.....	27
Analog Input.....	16	Modes of Operation.....	28
Internal Register Structure.....	18	Mode 1—Using the $\overline{\text{CONVST}}$ Pin.....	28
Address Pointer Register.....	18	Mode 2 – COMMAND MODE.....	29
Configuration Register.....	19	Mode 3—Automatic Cycle Interval Mode.....	30
Conversion Result Register.....	20	Outline Dimensions.....	31
Limit Registers.....	20	Ordering Guide.....	31
Alert Status Register (CH1 to CH4).....	21	Related Parts in I ² C-Compatible ADC Product Family.....	31
Cycle Timer Register.....	22		
Sample Delay and Bit Trial Delay.....	22		
Serial Interface.....	23		

REVISION HISTORY

9/04—Revision 0: Initial Version

AD7997 SPECIFICATIONS

Temperature range for B version is -40°C to $+85^{\circ}\text{C}$. Unless otherwise noted, $V_{\text{DD}} = 2.7\text{ V}$ to 5.5 V ; $\text{REF}_{\text{IN}} = 2.5\text{ V}$; For the AD7997-0, all specifications apply for f_{SCL} up to 400 kHz ; for the AD7997-1, all specifications apply for f_{SCL} up to 3.4 MHz , unless otherwise noted; $T_{\text{A}} = T_{\text{MIN}}$ to T_{MAX} .

Table 1.

Parameter	B Version	Unit	Test Conditions/Comments
DYNAMIC PERFORMANCE¹			
Signal to Noise + Distortion (SINAD) ²	61	dB min	$F_{\text{IN}} = 10\text{ kHz}$ sine wave for f_{SCL} from 1.7 MHz to 3.4 MHz $F_{\text{IN}} = 1\text{ kHz}$ sine wave for f_{SCL} up to 400 kHz
Total Harmonic Distortion (THD) ²	-75	dB max	
Peak Harmonic or Spurious Noise (SFDR) ²	-76	dB max	
Intermodulation Distortion (IMD) ²			$f_{\text{a}} = 10.1\text{ kHz}$, $f_{\text{b}} = 9.9\text{ kHz}$ for f_{SCL} from 1.7 MHz to 3.4 MHz $f_{\text{a}} = 1.1\text{ kHz}$, $f_{\text{b}} = 0.9\text{ kHz}$ for f_{SCL} up to 400 kHz
Second-Order Terms	-86	dB typ	
Third-Order Terms	-86	dB typ	
Aperture Delay ²	10	ns max	
Aperture Jitter ²	50	ps typ	
Channel-to-Channel Isolation ²	-90	dB typ	$F_{\text{IN}} = 108\text{ Hz}$, see the Terminology section
Full-Power Bandwidth ²	11	MHz typ	@ 3 dB
	2	MHz typ	@ 0.1 dB
DC ACCURACY			
Resolution	10	Bits	
Integral Nonlinearity ^{1,2}	± 0.5	LSB max	
Differential Nonlinearity ^{1,2}	± 0.5	LSB max	Guaranteed no missed codes to 10 bits
Offset Error ²	± 1.5	LSB max	Mode 1 ($\overline{\text{CONVST}}$ Mode)
	± 2.5	LSB max	Mode 2 (Command Mode)
Offset Error Match ²	± 0.5	LSB max	
Gain Error ²	± 1.5	LSB max	
Gain Error Match ²	± 0.5	LSB max	
ANALOG INPUT			
Input Voltage Range	0 to REF_{IN}	V	
DC Leakage Current	± 1	μA max	
Input Capacitance	30	pF typ	
REFERENCE INPUT			
REF_{IN} Input Voltage Range	1.2 to V_{DD}	V min/V max	
DC Leakage Current	± 1	μA max	
Input Impedance	69	$\text{k}\Omega$ typ	During a conversion
LOGIC INPUTS (SDA, SCL)			
Input High Voltage, V_{INH}	$0.7 (V_{\text{DD}})$	V min	
Input Low Voltage, V_{INL}	$0.3 (V_{\text{DD}})$	V max	
Input Leakage Current, I_{IN}	± 1	μA max	$V_{\text{IN}} = 0\text{ V}$ or V_{DD}
Input Capacitance, C_{IN}^3	10	pF max	
Input Hysteresis, V_{HYST}	$0.1 (V_{\text{DD}})$	V min	

AD7997/AD7998

Parameter	B Version	Unit	Test Conditions/Comments
LOGIC INPUTS (CONVST)			
Input High Voltage, V_{INH}	2.4	V min	$V_{DD} = 5\text{ V}$
	2.0	V min	$V_{DD} = 3\text{ V}$
Input Low Voltage, V_{INL}	0.8	V max	$V_{DD} = 5\text{ V}$
	0.4	V max	$V_{DD} = 3\text{ V}$
Input Leakage Current, I_{IN}	± 1	$\mu\text{A max}$	$V_{IN} = 0\text{ V or }V_{DD}$
Input Capacitance, C_{IN}^3	10	pF max	
LOGIC OUTPUTS (OPEN-DRAIN)			
Output Low Voltage, V_{OL}	0.4	V max	$I_{SINK} = 3\text{ mA}$
	0.6	V max	$I_{SINK} = 6\text{ mA}$
Floating-State Leakage Current	± 1	$\mu\text{A max}$	
Floating-State Output Capacitance ³	10	pF max	
Output Coding	Straight (Natural) Binary		
CONVERSION RATE			
Conversion Time	2	$\mu\text{s typ}$	See the Modes of Operation section
Throughput Rate			
Mode 1 (Reading after the Conversion)	5	kSPS typ	$f_{SCL} = 100\text{ kHz}$
	21	kSPS typ	$f_{SCL} = 400\text{ kHz}$
	121	kSPS typ	$f_{SCL} = 3.4\text{ MHz}$
Mode 2	5.5	kSPS typ	$f_{SCL} = 100\text{ kHz}$
	22	kSPS typ	$f_{SCL} = 400\text{ kHz}$
	147	kSPS typ	$f_{SCL} = 3.4\text{ MHz, }188\text{ kSPS typ @ }5\text{ V}$
POWER REQUIREMENTS			
V_{DD}	2.7/5.5	V min/max	
I_{DD}			Digital inputs = 0 V or V_{DD}
Power-Down Mode, Interface Inactive	1/2	$\mu\text{A max}$	$V_{DD} = 3.3\text{ V/}5.5\text{ V}$
Power-Down Mode, Interface Active	0.07/0.3	mA max	$V_{DD} = 3.3\text{ V/}5.5\text{ V, }400\text{ kHz }f_{SCL}$
	0.3/0.6	mA max	$V_{DD} = 3.3\text{ V/}5.5\text{ V, }3.4\text{ MHz }f_{SCL}$
Operating, Interface Inactive	0.06/0.1	mA max	$V_{DD} = 3.3\text{ V/}5.5\text{ V, }400\text{ kHz }f_{SCL}$
	0.3/0.6	mA max	$V_{DD} = 3.3\text{ V/}5.5\text{ V, }3.4\text{ MHz }f_{SCL}$
Operating, Interface Active	0.15/0.4	mA max	$V_{DD} = 3.3\text{ V/}5.5\text{ V, }400\text{ kHz }f_{SCL}$
	0.6/1.1	mA max	$V_{DD} = 3.3\text{ V/}5.5\text{ V, }3.4\text{ MHz }f_{SCL}\text{ Mode 1}$
	0.7/1.4	mA typ	$V_{DD} = 3.3\text{ V/}5.5\text{ V, }3.4\text{ MHz }f_{SCL}\text{ Mode 2}$
Mode 3 (I ² C Inactive, $T_{CONVERT} \times 32$)	0.7/1.5	mA max	$V_{DD} = 3.3\text{ V/}5.5\text{ V}$
Power Dissipation			
Fully Operational			
Operating, Interface Active	0.495/2.2	mW max	$V_{DD} = 3.3\text{ V/}5.5\text{ V, }400\text{ kHz }f_{SCL}$
	1.98/6.05	mW max	$V_{DD} = 3.3\text{ V/}5.5\text{ V, }3.4\text{ MHz }f_{SCL}\text{ Mode 1}$
	2.31/7.7	mW typ	$V_{DD} = 3.3\text{ V/}5.5\text{ V, }3.4\text{ MHz }f_{SCL}\text{ Mode 2}$
Power Down, Interface Inactive	3.3/11	$\mu\text{W max}$	$V_{DD} = 3.3\text{ V/}5.5\text{ V}$

¹ Max/min ac dynamic performance, INL and DNL specifications are typical specifications when operating in Mode 2 with I²C Hs-Mode SCL frequencies. Specifications outlined for Mode 2 apply to Mode 3 also. Sample delay and bit trial delay enabled.

² See the Terminology section.

³ Guaranteed by initial characterization.

AD7998 SPECIFICATIONS

Temperature range for B version is -40°C to $+85^{\circ}\text{C}$. Unless otherwise noted, $V_{\text{DD}} = 2.7\text{ V}$ to 5.5 V ; $\text{REF}_{\text{IN}} = 2.5\text{ V}$; For the AD7998-0, all specifications apply for f_{SCL} up to 400 kHz ; for the AD7998-1, all specifications apply for f_{SCL} up to 3.4 MHz , unless otherwise noted; $T_{\text{A}} = T_{\text{MIN}}$ to T_{MAX} .

Table 2.

Parameter	B Version	Unit	Test Conditions/Comments	
DYNAMIC PERFORMANCE¹				
Signal-to-Noise + Distortion (SINAD) ²	70.5	dB min	$F_{\text{IN}} = 10\text{ kHz}$ sine wave for f_{SCL} from 1.7 MHz to 3.4 MHz $F_{\text{IN}} = 1\text{ kHz}$ sine wave for f_{SCL} up to 400 kHz $f_{\text{a}} = 10.1\text{ kHz}$, $f_{\text{b}} = 9.9\text{ kHz}$ f_{SCL} from 1.7 MHz to 3.4 MHz $f_{\text{a}} = 1.1\text{ kHz}$, $f_{\text{b}} = 0.9\text{ kHz}$ for f_{SCL} up to 400 kHz	
Signal to Noise Ratio (SNR) ²	71	dB min		
Total Harmonic Distortion (THD) ²	-78	dB max		
Peak Harmonic or Spurious Noise (SFDR) ²	-79	dB max		
Intermodulation Distortion (IMD) ²				
Second-Order Terms	-90	dB typ		
Third-Order Terms	-90	dB typ		
Aperture Delay ²	10	ns max		
Aperture Jitter ²	50	ps typ		
Channel-to-Channel Isolation ²	-90	dB typ		$F_{\text{IN}} = 108\text{ Hz}$, see the Terminology section
Full-Power Bandwidth ²	11	MHz typ		
	2	MHz typ	@ 3 dB @ 0.1 dB	
DC ACCURACY				
Resolution	12	Bits	Guaranteed no missed codes to 12 bits	
Integral Nonlinearity ^{1,2}	± 1	LSB max		
	± 0.2	LSB typ		
Differential Nonlinearity ^{1,2}	$+1/-0.9$	LSB max		
	± 0.2	LSB typ		
Offset Error ²	± 4	LSB max		Mode 1 ($\overline{\text{CONVST}}$ Mode) Mode 2 (Command Mode)
	± 6	LSB max		
Offset Error Match ²	± 1	LSB max		
Gain Error ²	± 2	LSB max		
Gain Error Match ²	± 1	LSB max		
ANALOG INPUT				
Input Voltage Range	0 to REF_{IN}	V		
DC Leakage Current	± 1	μA max		
Input Capacitance	30	pF typ		
REFERENCE INPUT				
REF_{IN} Input Voltage Range	1.2 to V_{DD}	V min/V max		
DC Leakage Current	± 1	μA max		
Input Impedance	69	$\text{k}\Omega$ typ		
LOGIC INPUTS (SDA, SCL)				
Input High Voltage, V_{INH}	$0.7 (V_{\text{DD}})$	V min	$V_{\text{IN}} = 0\text{ V}$ or V_{DD}	
Input Low Voltage, V_{INL}	$0.3 (V_{\text{DD}})$	V max		
Input Leakage Current, I_{IN}	± 1	μA max		
Input Capacitance, C_{IN}^3	10	pF max		
Input Hysteresis, V_{HYST}	$0.1 (V_{\text{DD}})$	V min		

AD7997/AD7998

Parameter	B Version	Unit	Test Conditions/Comments
LOGIC INPUTS (CONVST)			
Input High Voltage, V_{INH}	2.4	V min	$V_{DD} = 5\text{ V}$
	2.0	V min	$V_{DD} = 3\text{ V}$
Input Low Voltage, V_{INL}	0.8	V max	$V_{DD} = 5\text{ V}$
	0.4	V max	$V_{DD} = 3\text{ V}$
Input Leakage Current, I_{IN}	± 1	$\mu\text{A max}$	$V_{IN} = 0\text{ V or }V_{DD}$
Input Capacitance, C_{IN}^3	10	pF max	
LOGIC OUTPUTS (OPEN-DRAIN)			
Output Low Voltage, V_{OL}	0.4	V max	$I_{SINK} = 3\text{ mA}$
	0.6	V max	$I_{SINK} = 6\text{ mA}$
Floating-State Leakage Current	± 1	$\mu\text{A max}$	
Floating-State Output Capacitance ³	10	pF max	
Output Coding	Straight (Natural) Binary		
CONVERSION RATE			
Conversion Time	2	$\mu\text{s typ}$	See the Modes of Operation section
Throughput Rate			
Mode 1 (Reading after the Conversion)	5	kSPS typ	$f_{SCL} = 100\text{ kHz}$
	21	kSPS typ	$f_{SCL} = 400\text{ kHz}$
	121	kSPS typ	$f_{SCL} = 3.4\text{ MHz}$
Mode 2	5.5	kSPS typ	$f_{SCL} = 100\text{ kHz}$
	22	kSPS typ	$f_{SCL} = 400\text{ kHz}$
	147	kSPS typ	$f_{SCL} = 3.4\text{ MHz, }188\text{ kSPS typ @ }5\text{ V}$
POWER REQUIREMENTS			
V_{DD}	2.7/5.5	V min/max	
I_{DD}			Digital inputs = 0 V or V_{DD}
Power-Down Mode, Interface Inactive	1/2	$\mu\text{A max}$	$V_{DD} = 3.3\text{ V/5.5 V}$
Power-Down Mode, Interface Active	0.07/0.3	mA max	$V_{DD} = 3.3\text{ V/5.5 V, }400\text{ kHz }f_{SCL}$
	0.3/0.6	mA max	$V_{DD} = 3.3\text{ V/5.5 V, }3.4\text{ MHz }f_{SCL}$
Operating, Interface Inactive	0.06/0.1	mA max	$V_{DD} = 3.3\text{ V/5.5 V, }400\text{ kHz }f_{SCL}$
	0.3/0.6	mA max	$V_{DD} = 3.3\text{ V/5.5 V, }3.4\text{ MHz }f_{SCL}$
Operating, Interface Active	0.15/0.4	mA max	$V_{DD} = 3.3\text{ V/5.5 V, }400\text{ kHz }f_{SCL}$
	0.6/1.1	mA max	$V_{DD} = 3.3\text{ V/5.5 V, }3.4\text{ MHz }f_{SCL}$ Mode 1
	0.7/1.4	mA typ	$V_{DD} = 3.3\text{ V/5.5 V, }3.4\text{ MHz }f_{SCL}$ Mode 2
Mode 3 (I ² C Inactive, $T_{CONVERT} \times 32$)	0.7/1.5	mA max	$V_{DD} = 3.3\text{ V/5.5 V}$
Power Dissipation			
Fully Operational			
Operating, Interface Active	0.495/2.2	mW max	$V_{DD} = 3.3\text{ V/5.5 V, }400\text{ kHz }f_{SCL}$
	1.98/6.05	mW max	$V_{DD} = 3.3\text{ V/5.5 V, }3.4\text{ MHz }f_{SCL}$ Mode 1
	2.31/7.7	mW typ	$V_{DD} = 3.3\text{ V/5.5 V, }3.4\text{ MHz }f_{SCL}$ Mode 2
Power Down, Interface Inactive	3.3/11	$\mu\text{W max}$	$V_{DD} = 3.3\text{ V/5.5 V}$

¹ Max/min ac dynamic performance, INL and DNL specifications are typical specifications when operating in Mode 2 with I²C Hs-Mode SCL frequencies. Specifications outlined for Mode 2 apply to Mode 3 also. Sample delay and bit trial delay enabled.

² See the Terminology section.

³ Guaranteed by initial characterization.

I²C TIMING SPECIFICATIONS

Guaranteed by initial characterization. All values measured with input filtering enabled. C_B refers to capacitive load on the bus line. t_r and t_f measured between 0.3 VDD and 0.7 VDD.

High speed mode timing specifications apply to the AD7997-1/AD7998-1 only. Standard and fast mode timing specifications apply to both the AD7997-0/AD7998-0 and the AD7997-1/AD7998-1. See Figure 2. Unless otherwise noted, $V_{DD} = 2.7\text{ V to }5.5\text{ V}$; $REF_{IN} = 2.5\text{ V}$; $T_A = T_{MIN}$ to T_{MAX} .

Table 3.

Parameter	Conditions	AD7997/AD7998 Limit at T_{MIN} , T_{MAX}			Description
		Min	Max	Unit	
f_{SCL}	Standard mode Fast mode High speed mode $C_B = 100\text{ pF max}$ $C_B = 400\text{ pF max}$		100 400 3.4 1.7	kHz kHz MHz MHz	Serial clock frequency
t_1	Standard mode Fast mode High speed mode $C_B = 100\text{ pF max}$ $C_B = 400\text{ pF max}$	4 0.6 60 120		μs μs ns ns	t_{HIGH} , SCL high time
t_2	Standard mode Fast mode High speed mode $C_B = 100\text{ pF max}$ $C_B = 400\text{ pF max}$	4.7 1.3 160 320		μs μs ns ns	t_{LOW} , SCL low time
t_3	Standard mode Fast mode High speed mode	250 100 10		ns ns ns	$t_{SU,DAT}$, data setup time
t_4^1	Standard mode Fast mode High speed mode $C_B = 100\text{ pF max}$ $C_B = 400\text{ pF max}$	0 0 0 0	3.45 0.9 70 ² 150	μs μs ns ns	$t_{HD,DAT}$, data hold time
t_5	Standard mode Fast mode High speed mode	4.7 0.6 160		μs μs ns	$t_{SU,STA}$, setup time for a repeated start condition
t_6	Standard mode Fast mode High speed mode	4 0.6 160		μs μs ns	$t_{HD,STA}$, hold time (repeated) start condition
t_7	Standard mode Fast mode	4.7 1.3		μs μs	t_{BUF} , bus free time between a stop and a start condition
t_8	Standard mode Fast mode High speed mode	4 0.6 160		μs μs ns	$t_{SU,STO}$, setup time for stop condition
t_9	Standard mode Fast mode High speed mode $C_B = 100\text{ pF max}$ $C_B = 400\text{ pF max}$		1000 300 80 160	ns ns ns ns	t_{RDA} , rise time of SDA signal

AD7997/AD7998

Parameter	Conditions	AD7997/AD7998 Limit at T _{MIN} , T _{MAX}			Description
		Min	Max	Unit	
t ₁₀	Standard mode		300	ns	t _{FDA} , fall time of SDA signal
	Fast mode	20 + 0.1 C _B	300	ns	
	High speed mode				
	C _B = 100 pF max C _B = 400 pF max	10 20	80 160	ns ns	
t ₁₁	Standard mode		1000	ns	t _{RCL} , rise time of SCL signal
	Fast mode	20 + 0.1 C _B	300	ns	
	High speed mode				
	C _B = 100 pF max C _B = 400 pF max	10 20	40 80	ns ns	
t _{11A}	Standard mode		1000	ns	t _{RCL1} , rise time of SCL signal after a repeated start condition and after an Acknowledge bit
	Fast mode	20 + 0.1 C _B	300	ns	
	High speed mode				
	C _B = 100 pF max C _B = 400 pF max	10 20	80 160	ns ns	
t ₁₂	Standard mode		300	ns	t _{FCL} , fall time of SCL signal
	Fast mode	20 + 0.1 C _B	300	ns	
	High speed mode				
	C _B = 100 pF max C _B = 400 pF max	10 20	40 80	ns ns	
t _{SP}	Fast mode	0	50	ns	Pulse width of suppressed spike
	High speed mode	0	10	ns	
t _{POWER-UP}		1		typ μs	Power-up time

¹ A device must provide a data hold time for SDA in order to bridge the undefined region of the SCL falling edge.

² For 3 V supplies, the maximum hold time with C_B = 100 pF max is 100 ns max.

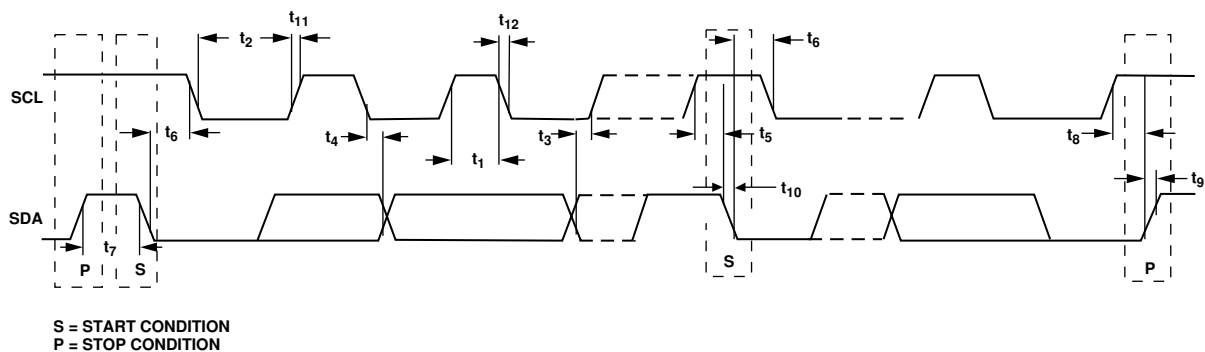

Figure 2. Timing Diagram for 2-Wire Serial Interface

03473-0-002

ABSOLUTE MAXIMUM RATINGS

$T_A = 25^\circ\text{C}$, unless otherwise noted.

Table 4.

Parameter	Rating
V_{DD} to GND	-0.3 V to 7 V
Analog Input Voltage to GND	-0.3 V to $V_{DD} + 0.3$ V
Reference Input Voltage to GND	-0.3 V to $V_{DD} + 0.3$ V
Digital Input Voltage to GND	-0.3 V to +7 V
Digital Output Voltage to GND	-0.3 V to $V_{DD} + 0.3$ V
Input Current to Any Pin Except Supplies ¹	± 10 mA
Operating Temperature Range	
Commercial (B Version)	-40°C to $+85^\circ\text{C}$
Storage Temperature Range	-65°C to $+150^\circ$
Junction Temperature	150°C
20-Lead TSSOP	
θ_{JA} Thermal Impedance	$143^\circ\text{C}/\text{W}$
θ_{JC} Thermal Impedance	$45^\circ\text{C}/\text{W}$
Pb/SN Temperature, Soldering	
Reflow (10 s to 30 s)	$240 (+0/-5)^\circ\text{C}$
Pb-free Temperature, Soldering	
Reflow	$260 (+0)^\circ\text{C}$
ESD	1.5 kV

Stresses above those listed under Absolute Maximum Ratings may cause permanent damage to the device. This is a stress rating only; functional operation of the device at these or any other conditions above those listed in the operational sections of this specification is not implied. Exposure to absolute maximum rating conditions for extended periods may affect device reliability.

¹ Transient currents of up to 100 mA do not cause SCR latch-up.

ESD CAUTION

ESD (electrostatic discharge) sensitive device. Electrostatic charges as high as 4000 V readily accumulate on the human body and test equipment and can discharge without detection. Although this product features proprietary ESD protection circuitry, permanent damage may occur on devices subjected to high energy electrostatic discharges. Therefore, proper ESD precautions are recommended to avoid performance degradation or loss of functionality.



AD7997/AD7998

PIN CONFIGURATION AND PIN FUNCTION DESCRIPTIONS

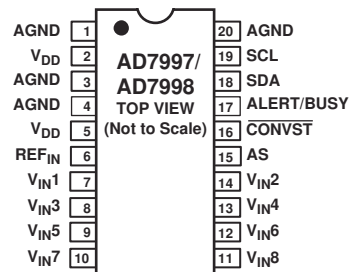

Figure 3. AD7998/AD7997 Pin Configuration

Table 5. Pin Function Descriptions

Pin No.	Mnemonic	Function
1, 3, 4, 20	AGND	Analog Ground. Ground reference point for all circuitry on the AD7997/AD7998. All analog input signals should be referred to this AGND voltage.
2, 5	V _{DD}	Power Supply Input. The V _{DD} range for the AD7997/AD7998 is from 2.7 V to 5.5 V.
6	REF _{IN}	Voltage Reference Input. The external reference for the AD7997/AD7998 should be applied to this input pin. The voltage range for the external reference is 1.2 V to V _{DD} . A 0.1 μF and 1 μF capacitors should be placed between REF _{IN} and AGND. See Typical Connection Diagram.
7	V _{IN1}	Analog Input 1. Single-ended analog input channel. The input range is 0 V to REF _{IN} .
8	V _{IN3}	Analog Input 3. Single-ended analog input channel. The input range is 0 V to REF _{IN} .
9	V _{IN5}	Analog Input 5. Single-ended analog input channel. The input range is 0 V to REF _{IN} .
10	V _{IN7}	Analog Input 7. Single-ended analog input channel. The input range is 0 V to REF _{IN} .
11	V _{IN8}	Analog Input 8. Single-ended analog input channel. The input range is 0 V to REF _{IN} .
12	V _{IN6}	Analog Input 6. Single-ended analog input channel. The input range is 0 V to REF _{IN} .
13	V _{IN4}	Analog Input 4. Single-ended analog input channel. The input range is 0 V to REF _{IN} .
14	V _{IN2}	Analog Input 2. Single-ended analog input channel. The input range is 0 V to REF _{IN} .
15	AS	Logic Input. Address select input that selects one of three I ² C addresses for the AD7997/AD7998, as shown in Table 6. The device address depends on the voltage applied to this pin.
16	CONVST	Logic Input Signal. Convert start signal. This is an edge-triggered logic input. The rising edge of this signal powers up the part. The power-up time for the part is 1 μs. The falling edge of CONVST places the track/hold into hold mode and initiates a conversion. A power-up time of at least 1 μs must be allowed for the CONVST high pulse; otherwise, the conversion result is invalid (see the Modes of Operation section).
17	ALERT/BUSY	Digital Output. Selectable as an ALERT or BUSY output function. When configured as an ALERT, this pin acts as an out-of-range indicator and, if enabled, becomes active when the conversion result violates the DATAHIGH or DATALOW register values. See the Limit Registers section. When configured as a BUSY output, this pin becomes active when a conversion is in progress. Open-drain output.
18	SDA	Digital I/O. Serial bus bidirectional data. Open-drain output. External pull-up resistor required.
19	SCL	Digital Input. Serial bus clock. Open-drain input. External pull-up resistor required.

Table 6. I²C Address Selection

Part Number	AS Pin	I ² C Address
AD7997-0	AGND	010 0001
AD7997-0	V _{DD}	010 0010
AD7997-1	AGND	010 0011
AD7997-1	V _{DD}	010 0100
AD7997-x ¹	Float	010 0000
AD7998-0	AGND	010 0001
AD7998-0	V _{DD}	010 0010
AD7998-1	AGND	010 0011
AD7998-1	V _{DD}	010 0100
AD7998-x ¹	Float	010 0000

¹ If the AS pin is left floating on any of the AD7997/AD7998 parts, the device address is 010 0000.

TERMINOLOGY

Signal-to-Noise and Distortion Ratio (SINAD)

The measured ratio of signal-to-noise and distortion at the output of the A/D converter. The signal is the rms amplitude of the fundamental. Noise is the sum of all nonfundamental signals up to half the sampling frequency ($f_s/2$), excluding dc. The ratio is dependent on the number of quantization levels in the digitization process; the more levels, the smaller the quantization noise. The theoretical signal-to-noise and distortion ratio for an ideal N-bit converter with a sine wave input is given by

$$\text{Signal-to-(Noise + Distortion)} = (6.02 N + 1.76) \text{ dB}$$

Thus, the SINAD is 61.96 dB for a 10-bit converter and 74 dB for a 12-bit converter.

Total Harmonic Distortion (THD)

The ratio of the rms sum of harmonics to the fundamental. For the AD7997/AD7998, it is defined as

$$\text{THD (dB)} = 20 \log \frac{\sqrt{V_2^2 + V_3^2 + V_4^2 + V_5^2 + V_6^2}}{V_1}$$

where V_1 is the rms amplitude of the fundamental and $V_2, V_3, V_4, V_5,$ and V_6 are the rms amplitudes of the second through sixth harmonics.

Peak Harmonic or Spurious Noise

The ratio of the rms value of the next largest component in the ADC output spectrum (up to $f_s/2$ and excluding dc) to the rms value of the fundamental. Typically, the value of this specification is determined by the largest harmonic in the spectrum, but for ADCs where the harmonics are buried in the noise floor, it is a noise peak.

Intermodulation Distortion

With inputs consisting of sine waves at two frequencies, f_a and f_b , any active device with nonlinearities creates distortion products at sum and difference frequencies of $m f_a \pm n f_b$, where $m, n = 0, 1, 2, 3,$ and so on. Intermodulation distortion terms are those for which neither m nor n equal zero. For example, second-order terms include $(f_a + f_b)$ and $(f_a - f_b)$, while third-order terms include $(2f_a + f_b), (2f_a - f_b), (f_a + 2f_b)$ and $(f_a - 2f_b)$.

The AD7997/AD7998 is tested using the CCIF standard where two input frequencies near the top end of the input bandwidth are used. In this case, the second-order terms are usually distanced in frequency from the original sine waves while the third-order terms are usually at a frequency close to the input frequencies. As a result, the second and third-order terms are specified separately. The calculation of intermodulation distortion is, like the THD specification, the ratio of the rms sum of the individual distortion products to the rms amplitude of the sum of the fundamentals, expressed in dB.

Channel-to-Channel Isolation

A measure of the level of crosstalk between channels, taken by applying a full-scale sine wave signal to the unselected input channels, and determining how much the 108 Hz signal is attenuated in the selected channel. The sine wave signal applied to the unselected channels is then varied from 1 kHz up to 2 MHz, each time determining how much the 108 Hz signal in the selected channel is attenuated. This figure represents the worst-case level across all channels.

Aperture Delay

The measured interval between the sampling clock's leading edge and the point at which the ADC takes the sample.

Aperture Jitter

This is the sample-to-sample variation in the effective point in time at which the sample is taken.

Full-Power Bandwidth

The input frequency at which the amplitude of the reconstructed fundamental is reduced by 0.1 dB or 3 dB for a full-scale input.

Power Supply Rejection Ratio (PSRR)

The ratio of the power in the ADC output at the full-scale frequency, f_s to the power of a 200 mV p-p sine wave applied to the ADC V_{DD} supply of frequency f_s :

$$\text{PSRR (dB)} = 10 \log (P_f/P_{f_s})$$

where P_f is the power at frequency f in the ADC output; P_{f_s} is the power at frequency f_s coupled onto the ADC V_{DD} supply.

Integral Nonlinearity

The maximum deviation from a straight line passing through the endpoints of the ADC transfer function. The endpoints are zero scale, a point 1 LSB below the first code transition, and full scale, a point 1 LSB above the last code transition.

Differential Nonlinearity

The difference between the measured and the ideal 1 LSB change between any two adjacent codes in the ADC.

Offset Error

The deviation of the first code transition (00...000) to (00...001) from the ideal—that is, AGND + 1 LSB.

Offset Error Match

The difference in offset error between any two channels.

Gain Error

The deviation of the last code transition (111...110) to (111...111) from the ideal (that is, $\text{REF}_{IN} - 1 \text{ LSB}$) after the offset error has been adjusted out.

Gain Error Match

The difference in gain error between any two channels.

TYPICAL PERFORMANCE CHARACTERISTICS

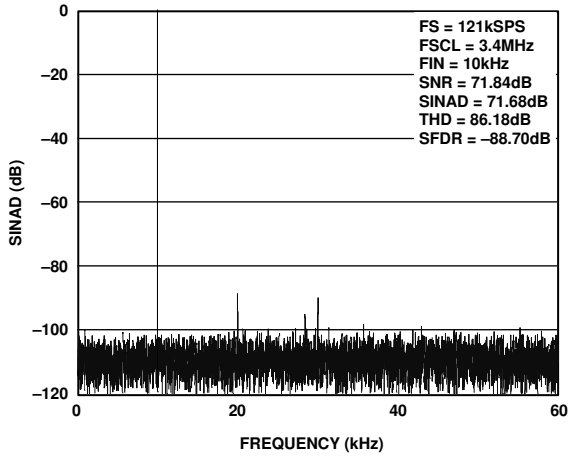

Figure 4. AD7998 Dynamic Performance with 5V Supply and 2.5V Reference, 121 kSPS, Mode 1

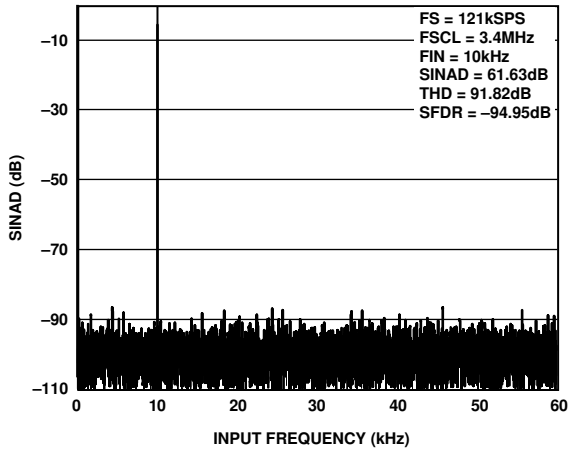

Figure 5. AD7997 Dynamic Performance with 5V Supply and 2.5V Reference, 121 kSPS, Mode 1

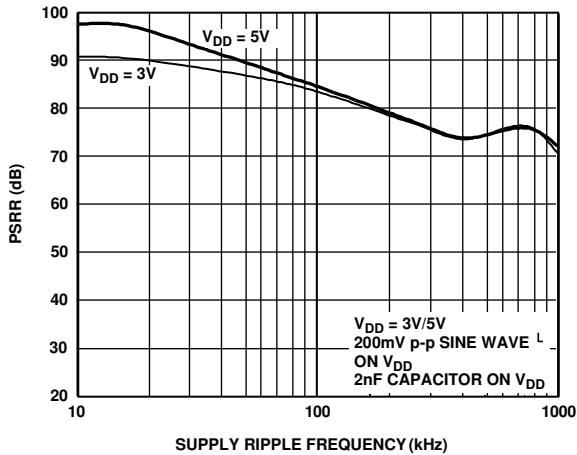

Figure 6. PSRR vs. Supply Ripple Frequency

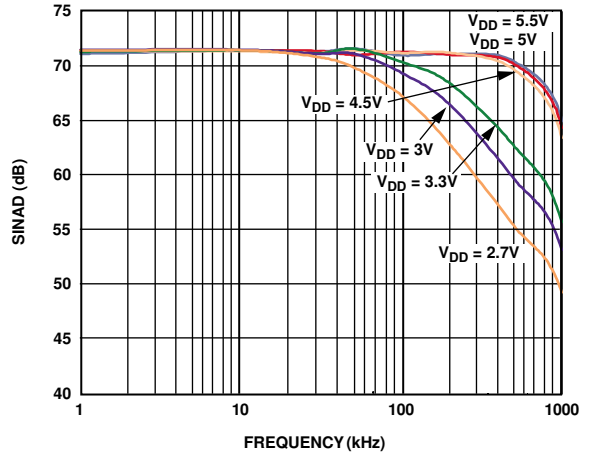

Figure 7. AD7998 SINAD vs. Analog Input Frequency for Various Supply Voltages, 3.4 MHz f_{SCL} , 136 kSPS

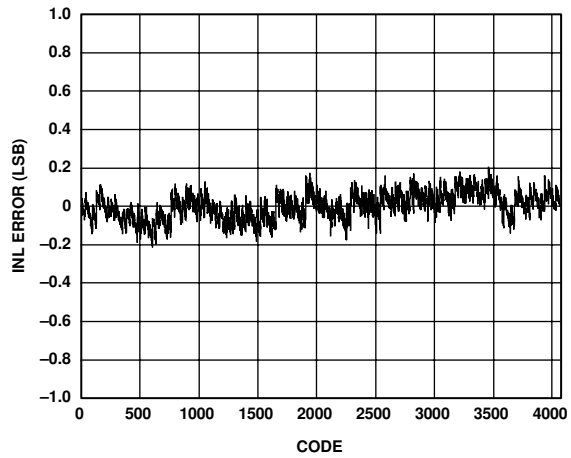

Figure 8. Typical INL, $V_{DD} = 5.5V$, Mode 1, 3.4 MHz f_{SCL} , 121 kSPS

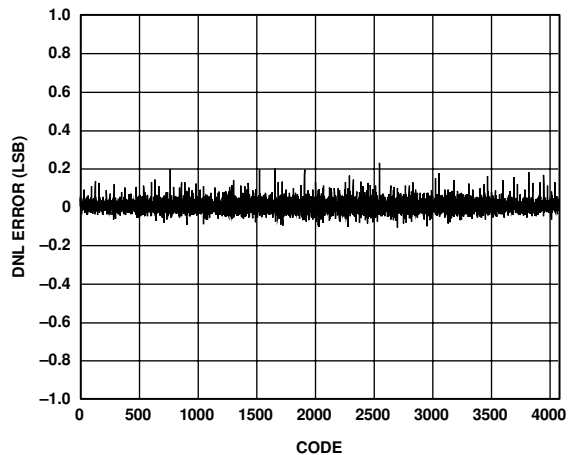

Figure 9. Typical DNL, $V_{DD} = 5.5V$, Mode 1, 3.4 MHz f_{SCL} , 121 kSPS

03473-0-004

03473-0-007

03473-0-005

03473-0-008

03473-0-006

03473-0-009

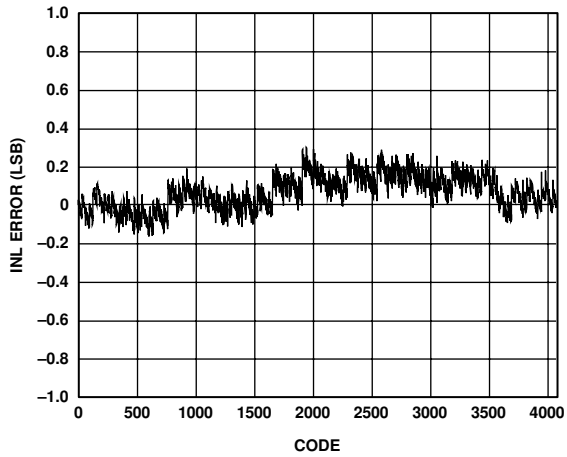

Figure 10. Typical INL, $V_{DD} = 2.7\text{ V}$, Mode 1, $3.4\text{ MHz } f_{SCL}$, 121 kSPS

03473-0-010

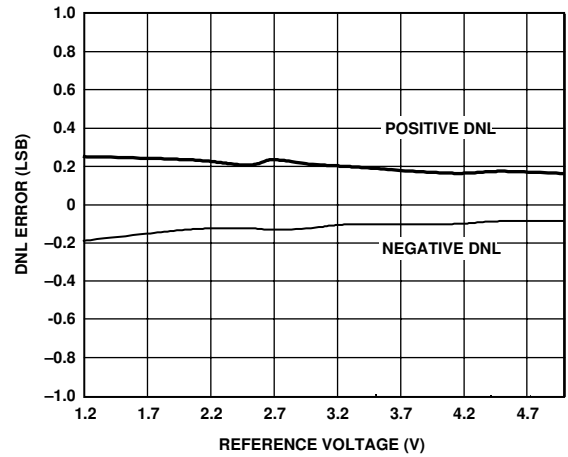

Figure 13. AD7998 Change in DNL vs. Reference Voltage $V_{DD} = 5\text{ V}$, Mode 1, 121 kSPS

03473-0-013

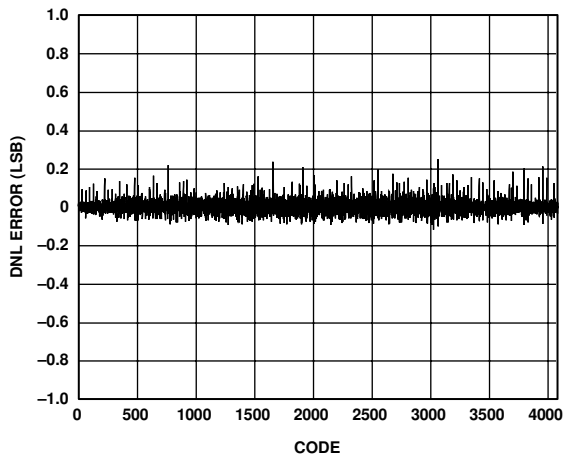

Figure 11. Typical DNL, $V_{DD} = 2.7\text{ V}$, Mode 1, $3.4\text{ MHz } f_{SCL}$, 121 kSPS

03473-0-011

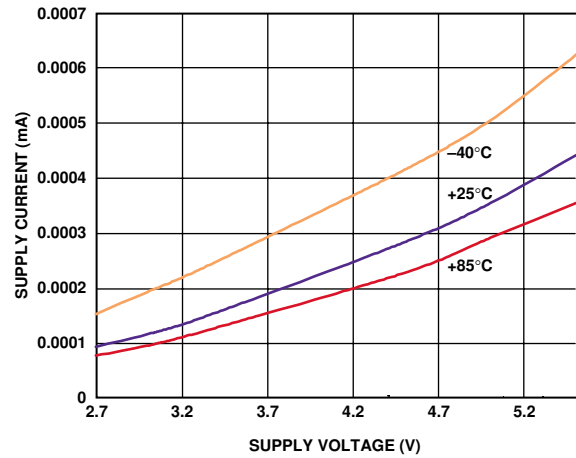

Figure 14. AD7998 Shutdown Current vs. Supply Voltage, -40°C , $+25^\circ\text{C}$, and $+85^\circ\text{C}$

03473-0-014

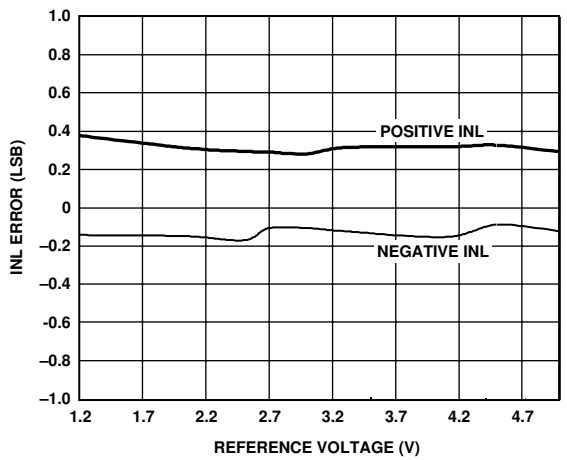

Figure 12. AD7998 Change in INL vs. Reference Voltage $V_{DD} = 5\text{ V}$, Mode 1, 121 kSPS

03473-0-012

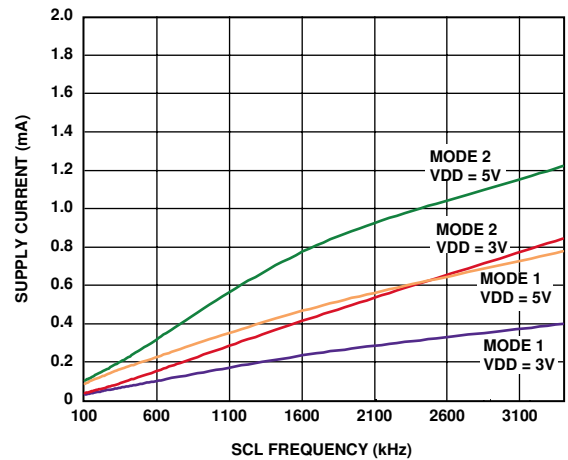

Figure 15. AD7998 Average Supply Current vs. I^2C Bus Rate for $V_{DD} = 3\text{ V}$ and 5 V

03473-0-015

AD7997/AD7998

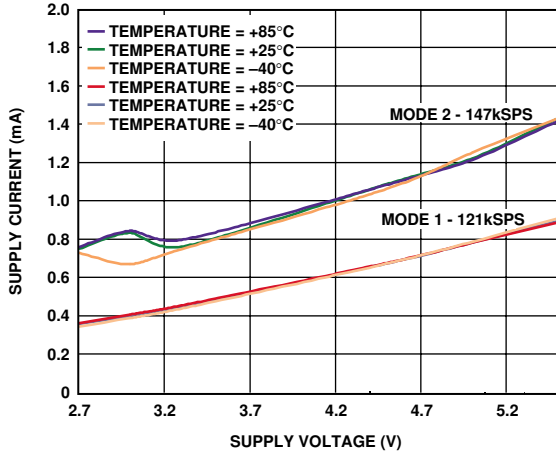

Figure 16. AD7998 Average Supply Current vs. Supply Voltage for Various Temperatures

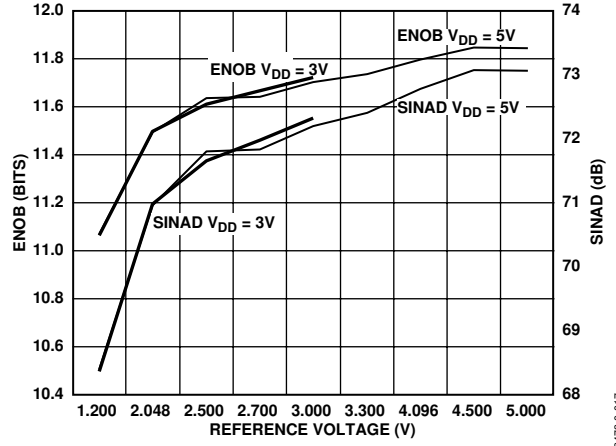

Figure 17. SINAD/ENOB vs. Reference Voltage, Mode 1, 121 kSPS

03473-0-016

03473-0-017

CIRCUIT INFORMATION

The AD7997/AD7998 are low power, 10- and 12-bit, single-supply, 8-channel A/D converters. The parts can be operated from a 2.7 V to 5.5 V supply.

The AD7997/AD7998 have an 8-channel multiplexer, an on-chip track-and-hold, an A/D converter, an on-chip oscillator, internal data registers, and an I²C-compatible serial interface, all housed in a 20-lead TSSOP. This package offers considerable space-saving advantages over alternative solutions. The AD7997/AD7998 require an external reference in the range of 1.2 V to V_{DD}.

The AD7997/AD7998 typically remain in a power-down state while not converting. When supplies are first applied, the parts come up in a power-down state. Power-up is initiated prior to a conversion, and the device returns to shutdown when the conversion is complete. Conversions can be initiated on the AD7997/AD7998 by pulsing the CONVST signal, using an automatic cycle interval mode, or a command mode where wake-up and a conversion occur during a write address function (see the Modes of Operation section). When the conversion is complete, the AD7997/AD7998 again enter shutdown mode. This automatic shutdown feature allows power saving between conversions. This means any read or write operation across the I²C interface can occur while the device is in shutdown.

CONVERTER OPERATION

The AD7997/AD7998 are successive approximation analog-to-digital converters based around a capacitive DAC. Figure 18 and Figure 19 show simplified schematics of the ADC during the acquisition and conversion phase, respectively. Figure 18 shows the acquisition phase. SW2 is closed and SW1 is in position A, the comparator is held in a balanced condition, and the sampling capacitor acquires the signal on V_{IN}.

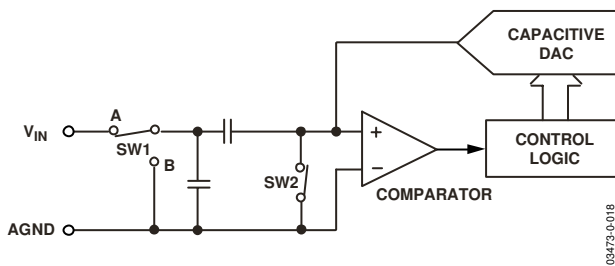

Figure 18. ADC Acquisition Phase

At the beginning of a conversion, SW2 opens and SW1 moves to position B, causing the comparator to become unbalanced, as shown in Figure 19. The input is disconnected once the conversion begins. The control logic and the capacitive DAC are used to add and subtract fixed amounts of charge from the sampling capacitor to bring the comparator back into a balanced condition. When the comparator is rebalanced, the conversion is complete. The control logic generates the ADC output code. Figure 20 shows the ADC transfer characteristic.

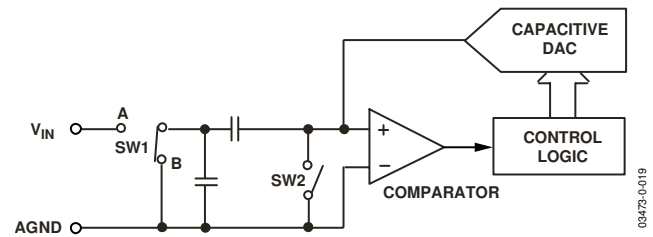

Figure 19. ADC Conversion Phase

ADC Transfer Function

The output coding of the AD7997/AD7998 is straight binary. The designed code transitions occur at successive integer LSB values (1 LSB, 2 LSB, and so on). The LSB size is REF_{IN}/1024 for the AD7997 and REF_{IN}/4096 for the AD7998. Figure 20 shows the ideal transfer characteristic for the AD7997/AD7998.

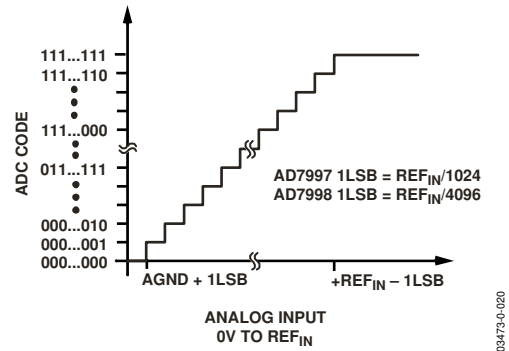

Figure 20. AD7997/AD7998 Transfer Characteristic

AD7997/AD7998

TYPICAL CONNECTION DIAGRAM

The typical connection diagram for the AD7997/AD7998 is shown in Figure 22. In this figure, the address select pin (AS) is tied to V_{DD} ; however, AS can also be tied to AGND or left floating, allowing the user to select up to five AD7997/AD7998 devices on the same serial bus. An external reference must be applied to the AD7997/AD7998. This reference can be in the range of 1.2 V to V_{DD} . A precision reference like the REF 19x family, AD780, ADR03, or ADR381 can be used to supply the reference voltage to the ADC.

SDA and SCL form the 2-wire I²C-/SMBus-compatible interface. External pull-up resistors are required for both SDA and SCL lines.

The AD7998-0/AD7997-0 support standard and fast I²C interface modes. The AD7998-1/AD7997-1 support standard, fast, and high speed I²C interface modes. Therefore if operating in either standard or fast mode, up to five AD7997/AD7998 devices can be connected to the bus, as noted:

- 3 × AD7997-0/AD7998-0 and 2 × AD7997-1/AD7998-1
- or
- 3 × AD7997-1/AD7998-1 and 2 × AD7997-0/AD7998-0

In high speed mode, up to three AD7997-1/AD7998-1 devices can be connected to the bus.

Wake-up from shutdown and acquisition prior to a conversion is approximately 1 μ s, and conversion time is approximately 2 μ s. The AD7997/AD7998 enters shutdown mode again after each conversion, which is useful in applications where power consumption is a concern.

ANALOG INPUT

Figure 21 shows an equivalent circuit of the AD7997/AD7998 analog input structure. The two diodes, D1 and D2, provide ESD protection for the analog inputs. Care must be taken to ensure that the analog input signal does not exceed the supply rails by more than 300 mV. This causes the diodes to become forward biased and start conducting current into the substrate. These diodes can conduct a maximum current of 10 mA without causing irreversible damage to the part.

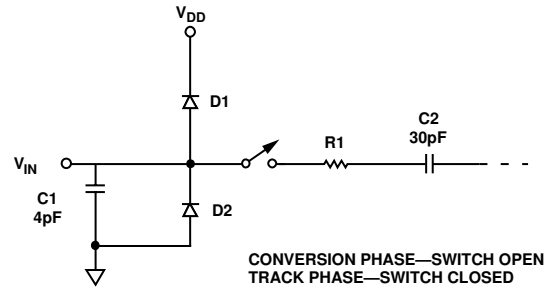

Figure 21. Equivalent Analog Input Circuit

Capacitor C1 in Figure 21 is typically about 4 pF and can primarily be attributed to pin capacitance. Resistor R1 is a lumped component made up of the on resistance (R_{ON}) of a track-and-hold switch, and also includes the R_{ON} of the input multiplexer. The total resistance is typically about 400 Ω . C2, the ADC sampling capacitor, has a typical capacitance of 30 pF.

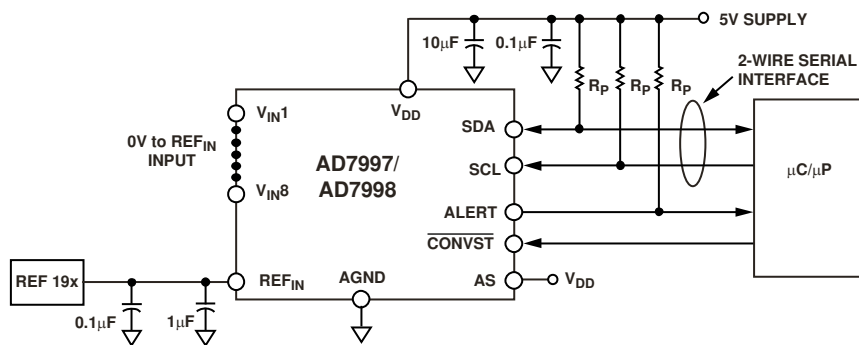

Figure 22. AD7997/AD7998 Typical Connection Diagram

For ac applications, removing high frequency components from the analog input signal is recommended, by using an RC band-pass filter on the relevant analog input pin. In applications where harmonic distortion and signal-to-noise ratio are critical, the analog input should be driven from a low impedance source. Large source impedances significantly affect the ac performance of the ADC. This may necessitate the use of an input buffer amplifier. The choice of the op amp is a function of the particular application.

When no amplifier is used to drive the analog input, the source impedance should be limited to low values. The maximum source impedance depends on the amount of total harmonic distortion (THD) that can be tolerated. THD increases as the source impedance increases, and performance degrades. Figure 23 shows the THD vs. the analog input signal frequency when using supply voltages of $3\text{ V} \pm 10\%$ and $5\text{ V} \pm 10\%$. Figure 24 shows the THD vs. the analog input signal frequency for different source impedances.

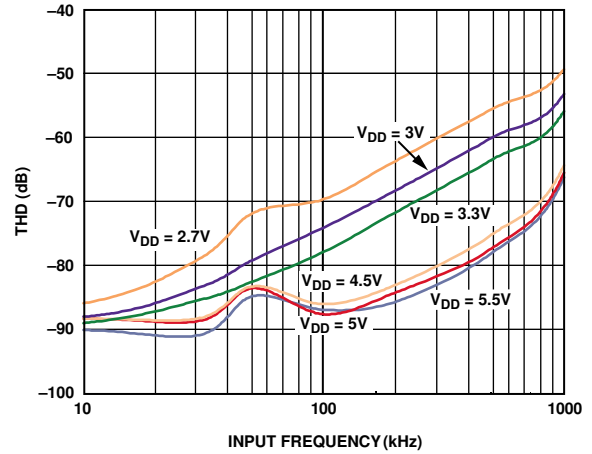

Figure 23. THD vs. Analog Input Frequency for Various Supply Voltages, $F_s = 136\text{ kSPS}$, Mode 1

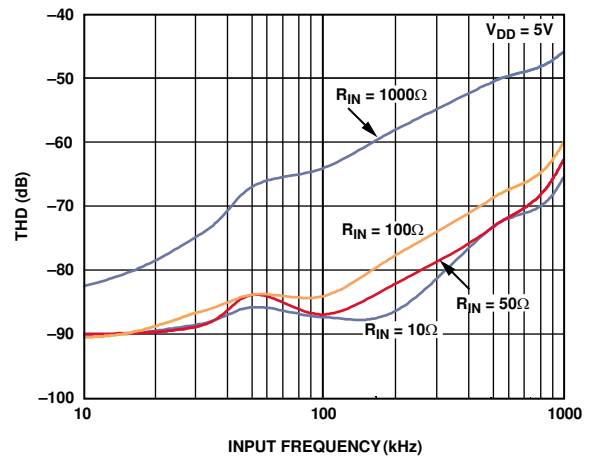

Figure 24. THD vs. Analog Input Frequency for Various Source Impedances for $V_{DD} = 5\text{ V}$, 136 kSPS , Mode 1

03473-0-023

03473-0-024

INTERNAL REGISTER STRUCTURE

The AD7997/AD7998 contain 17 internal registers that are used to store conversion results, high and low conversion limits, and information to configure and control the device (see Figure 25). Sixteen are data registers and one is an address pointer register.

Each data register has an address that the address pointer register points to when communicating with it. The conversion result register is the only data register that is read only.

ADDRESS POINTER REGISTER

Because it is the register to which the first data byte of every write operation is written automatically, the address pointer register does not have and does not require an address. The address pointer register is an 8-bit register in which the 4 LSBs are used as pointer bits to store an address that points to one of the AD7997/AD7998's data registers. The 4 MSBs are used as command bits when operating in Mode 2 (see the Modes of Operation section). The first byte following each write address is to the address pointer register, containing the address of one of the data registers. The 4 LSBs select the data register to which subsequent data bytes are written. Only the 4 LSBs of this register are used to select a data register. On power-up, the address pointer register contains all 0s, pointing to the conversion result register.

Table 7. Address Pointer Register

C4	C3	C2	C1	P3	P2	P1	P0
0	0	0	0	Register Select			

Table 8. AD7997/AD7998 Register Addresses

P3	P2	P1	P0	Registers
0	0	0	0	Conversion Result Register (Read)
0	0	0	1	Alert Status Register (Read/Write)
0	0	1	0	Configuration Register (Read/Write)
0	0	1	1	Cycle Timer Register (Read/Write)
0	1	0	0	DATA _{LOW} Reg CH1 (Read/Write)
0	1	0	1	DATA _{HIGH} Reg CH1 (Read/Write)
0	1	1	0	Hysteresis Reg CH1 (Read/Write)
0	1	1	1	DATA _{LOW} Reg CH2 (Read/Write)
1	0	0	0	DATA _{HIGH} Reg CH2 (Read/Write)
1	0	0	1	Hysteresis Reg CH2 (Read/Write)
1	0	1	0	DATA _{LOW} Reg CH3 (Read/Write)
1	0	1	1	DATA _{HIGH} Reg CH3 (Read/Write)
1	1	0	0	Hysteresis Reg CH3 (Read/Write)
1	1	0	1	DATA _{LOW} Reg CH4 (Read/Write)
1	1	1	0	DATA _{HIGH} Reg CH4 (Read/Write)
1	1	1	1	Hysteresis Reg CH4 (Read/Write)

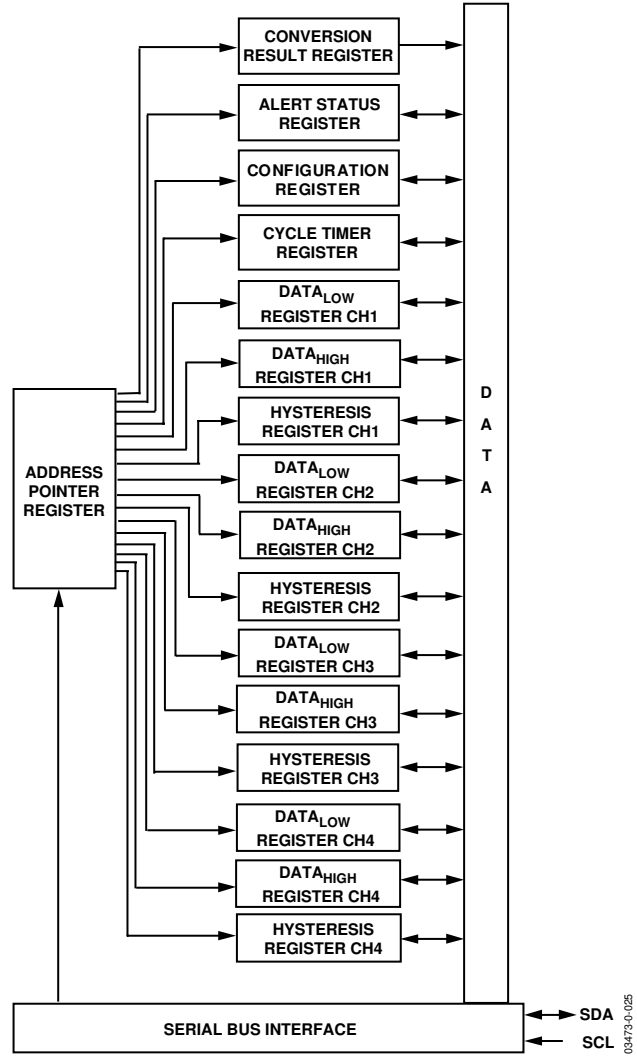

Figure 25. AD7997/AD7998 Register Structure

CONFIGURATION REGISTER

The configuration register is a 16-bit read/write register that is used to set the operating mode of the AD7997/AD7998. The 4 MSBs of the register are unused. The bit functions of all 12 LSBs of the configuration register are outlined in Table 9. A 2-byte write is necessary when writing to the configuration register.

Table 9. Configuration Register Bits and Default Settings at Power-Up

D15	D14	D13	D12	D11	D10	D9	D8	D7	D6	D5	D4	D3	D2	D1	D0
DONTC	DONTC	DONTC	DONTC	CH8	CH7	CH6	CH5	CH4	CH3	CH2	CH1	FLTR	ALERT EN	BUSY/ALERT	ALERT/BUSY POLARITY
0	0	0	0	0	0	0	0	0	0	0	0	1	0	0	0

Table 10. Bit Function Descriptions

Bit	Mnemonic	Comment
D11 to D4	CH8 to CH1	These 8-channel address bits select the analog input channel(s) to be converted. A 1 in any of Bits D11 to D4 selects a channel for conversion. If more than one channel bit is set to 1, the AD7997/AD7998 sequence through the selected channels, starting with the lowest channel. All unused channels should be set to 0. Prior to initiating a conversion, a channel or channels for conversion must be selected in the configuration register.
D3	FLTR	The value written to this bit of the control register determines whether the filtering on SDA and SCL is enabled or is to be bypassed. If this bit is a 1, then the filtering is enabled; if it is a 0, the filtering is bypassed.
D2	ALERT EN	The hardware ALERT function is enabled if this bit is set to 1, and disabled if this bit is set to 0. This bit is used in conjunction with the BUSY/ALERT bit to determine if the ALERT/BUSY pin acts as an ALERT or a BUSY output (see Table 12).
D1	BUSY/ALERT	This bit is used in conjunction with the ALERT EN bit to determine if the ALERT/ BUSY output, Pin 17, acts as an ALERT or BUSY output (see Table 12), and if Pin 17 is configured as an ALERT output pin, if it is to be reset.
D0	BUSY/ALERT POLARITY	This bit determines the active polarity of the ALERT/BUSY pin regardless of whether it is configured as an ALERT or BUSY output. It is active low if this bit is set to 0, and active high if set to 1.

Table 11. Channel Selection

D11	D10	D9	D8	D7	D6	D5	D4	Selected Analog Input Channel	Comments
0	0	0	0	0	0	0	1	Convert on Channel 1 (V_{IN1})	If more than one channel is selected, the AD7997/AD7998 start converting on the selected sequence of channels starting with the lowest channel in the sequence.
0	0	0	0	0	0	1	0	Convert on Channel 2 (V_{IN2})	
0	0	0	0	0	1	0	0	Convert on Channel 3 (V_{IN3})	
0	0	0	0	1	0	0	0	Convert on Channel 4 (V_{IN4})	
0	0	0	1	0	0	0	0	Convert on Channel 5 (V_{IN5})	
0	0	1	0	0	0	0	0	Convert on Channel 6 (V_{IN6})	
0	1	0	0	0	0	0	0	Convert on Channel 7 (V_{IN7})	
1	0	0	0	0	0	0	0	Convert on Channel 8 (V_{IN8})	

Table 12. ALERT/BUSY Function

D2	D1	ALERT/BUSY Pin Configuration
0	0	Pin does not provide any interrupt signal.
0	1	Pin configured as a BUSY output.
1	0	Pin configured as an ALERT output.
1	1	Resets the ALERT output pin, the Alert_Flag bit in the conversion result register, and the entire alert status register (if any is active). If 1/1 is written to Bits D2/D1 in the configuration register to reset the ALERT pin, the Alert_Flag bit, and the alert status register, the contents of the configuration register read 1/0 for D2/D1, respectively, if read back.

AD7997/AD7998

CONVERSION RESULT REGISTER

The conversion result register is a 16-bit, read-only register that stores the conversion result from the ADC in straight binary format. A 2-byte read is necessary to read data from this register. Table 13 shows the contents of the first byte to be read from the AD7997/AD7998, and Table 14 shows the contents of the second byte to be read.

Table 13. Conversion Value Register (First Read)

D15	D14	D13	D12	D11	D10	D9	D8
Alert_Flag	CH_ID2	CH_ID1	CH_ID0	MSB	B10	B9	B8

Table 14. Conversion Value Register (Second Read)

D7	D6	D5	D4	D3	D2	D1	D0
B7	B6	B5	B4	B3	B2	B1	B0

The AD7997/AD7998 conversion result consists of an Alert_Flag bit, three channel identifier bits, and the 10- and 12-bit data result (MSB first). For the AD7997, the 2 LSBs (D1 and D0) of the second read contain two 0s. The three channel identification bits can be used to identify to which of the eight analog input channels the conversion result corresponds.

The Alert_Flag bit indicates whether the conversion result being read or any other channel result has violated the limit registers associated with it. If an ALERT occurs, the master can read the ALERT status register to obtain more information on where the ALERT occurred.

LIMIT REGISTERS

The AD7997/AD7998 have four pairs of limit registers. Each pair stores high and low conversion limits for the first four analog input channels, CH1 to CH4. Each pair of limit registers has one associated hysteresis register. All 12 registers are 16 bits wide; only the 12 LSBs of the registers are used for the AD7997 and AD7998. For the AD7997, the 2 LSBs, D1 and D0 in these registers, should contain 0s. On power-up, the contents of the DATA_{HIGH} register for each channel is full scale, while the contents of the DATA_{LOW} registers is zero scale by default. The AD7997/AD7998 signal an alert (in either hardware, software, or both depending on configuration) if the conversion result moves outside the upper or lower limit set by the limit registers. There are no limit registers or hysteresis registers associated with CH5 to CH8.

DATA_{HIGH} Register CH1/CH2/CH3/CH4

The DATA_{HIGH} registers for CH1 to CH4 are 16-bit read/write registers; only the 12 LSBs of each register are used. This register stores the upper limit that activates the ALERT output and/or the Alert_Flag bit in the conversion result register. If the value in the conversion result register is greater than the value in the DATA_{HIGH} register, an ALERT occurs for that channel. When the conversion result returns to a value at least *N* LSBs below the DATA_{HIGH} register value, the ALERT output pin and Alert_Flag bit are reset. The value of *N* is taken from the hysteresis register associated with that channel. The ALERT pin can also be reset by writing to Bits D2 and D1 in the configuration register. For the AD7997, D1 and D0 of the DATA_{HIGH} register should contain 0s.

Table 15. DATA_{HIGH} Register (First Read/Write)

D15	D14	D13	D12	D11	D10	D9	D8
0	0	0	0	B11	B10	B9	B8

Table 16. DATA_{HIGH} Register (Second Read/Write)

D7	D6	D5	D4	D3	D2	D1	D0
B7	B6	B5	B4	B3	B2	B1	B0

DATA_{LOW} Register CH1/CH2/CH3/CH4

The DATA_{LOW} register for each channel is a 16-bit read/write register; only the 12 LSBs of each register are used. The register stores the lower limit that activates the ALERT output and/or the Alert_Flag bit in the conversion result register. If the value in the conversion result register is less than the value in the DATA_{LOW} register, an ALERT occurs for that channel. When the conversion result returns to a value at least *N* LSBs above the DATA_{LOW} register value, the ALERT output pin and Alert_Flag bit are reset. The value of *N* is taken from the hysteresis register associated with that channel. The ALERT output pin can also be reset by writing to Bits D2 and D1 in the configuration register. For the AD7997, D1 to D0 of the DATA_{LOW} register should contain 0s.

Table 17. DATA_{LOW} Register (First Read/Write)

D15	D14	D13	D12	D11	D10	D9	D8
0	0	0	0	B11	B10	B9	B8

Table 18. DATA_{LOW} Register (Second Read/Write)

D7	D6	D5	D4	D3	D2	D1	D0
B7	B6	B5	B4	B3	B2	B1	B0

Hysteresis Register (CH1/CH2/CH3/CH4)

Each hysteresis register is a 16-bit read/write register, of which only the 12 LSBs are used. The hysteresis register stores the hysteresis value, N , when using the limit registers. Each pair of limit registers has a dedicated hysteresis register. The hysteresis value determines the reset point for the ALERT pin/Alert_Flag if a violation of the limits has occurred. For example, if a hysteresis value of 8 LSBs is required on the upper and lower limits of Channel 1, the 12-bit word, 0000 0000 0000 1000, should be written to the hysteresis register of CH1, the address of which is shown in Table 8. On power-up, the hysteresis registers contain a value of 2 for the AD7997 and a value of 8 for the AD7998. If a different hysteresis value is required, that value must be written to the hysteresis register for the channel in question. For the AD7997, D1 and D0 of the hysteresis register should contain 0s.

Table 19. Hysteresis Register (First Read/Write)

D15	D14	D13	D12	D11	D10	D9	D8
0	0	0	0	B11	B10	B9	B8

Table 20. Hysteresis Register (Second Read/Write)

D7	D6	D5	D4	D3	D2	D1	D0
B7	B6	B5	B4	B3	B2	B1	B0

Using the Limit Registers to Store Min/Max Conversion Results for CH1 to CH4

If full scale, that is, all 1s, is written to the hysteresis register for a particular channel, the DATA_{HIGH} and DATA_{LOW} registers for that channel no longer act as limit registers as previously described, but instead act as storage registers for the maximum and minimum conversion results returned from conversions on a channel over any given period of time. This function is useful in applications where the widest span of actual conversion results is required rather than using the ALERT to signal that an intervention is necessary. This function could be useful for monitoring temperature extremes during refrigerated goods transportation. It must be noted that on power-up, the contents of the DATA_{HIGH} register for each channel are full scale, while the contents of the DATA_{LOW} registers are zero scale by default. Therefore, minimum and maximum conversion values being stored in this way are lost if power is removed or cycled.

ALERT STATUS REGISTER (CH1 TO CH4)

The alert status register is an 8-bit, read/write register that provides information on an alert event. If a conversion result activates the ALERT pin or the Alert_Flag bit in the conversion result register, as described in the Limit Registers section, the alert status register may be read to gain further information. The Alert Status Register contains two status bits per channel, one corresponding to the DATA_{HIGH} limit and the other to the DATA_{LOW} limit. The bit with a status of 1 shows where the violation occurred—that is, on which channel—and whether the violation occurred on the upper or lower limit. If a second alert event occurs on the other channel between receiving the first alert and interrogating the alert status register, the corresponding bit for that alert event is also set.

The alert status register only contains information for CH1 to CH4 because these are the only channels with associated limit registers.

The entire contents of the alert status register can be cleared by writing 1,1, to Bits D2 and D1 in the configuration register, as shown in Table 12. This may also be done by writing all 1s to the alert status register itself. Thus, if the alert status register is addressed for a write operation, which is all 1s, the contents of the alert status register are cleared or reset to all 0s.

Table 21. Alert Status Register

D7	D6	D5	D4	D3	D2	D1	D0
CH4 _{HI}	CH4 _{LO}	CH3 _{HI}	CH3 _{LO}	CH2 _{HI}	CH2 _{LO}	CH1 _{HI}	CH1 _{LO}

Table 22. Alert Status Register Bit Function Description

Bit	Mnemonic	If bit is set to 1, violation of...
D0	CH1 _{LO}	DATA _{LOW} limit on Channel 1. No violation if bit is set to 0.
D1	CH1 _{HI}	DATA _{HIGH} limit on Channel 1. No violation if bit is set to 0.
D2	CH2 _{LO}	DATA _{LOW} limit on Channel 2. No violation if bit is set to 0.
D3	CH2 _{HI}	DATA _{HIGH} limit on Channel 2. No violation if bit is set to 0.
D4	CH3 _{LO}	DATA _{LOW} limit on Channel 3. No violation if bit is set to 0.
D5	CH3 _{HI}	DATA _{HIGH} limit on Channel 3. No violation if bit is set to 0.
D6	CH4 _{LO}	DATA _{LOW} limit on Channel 4. No violation if bit is set to 0.
D7	CH4 _{HI}	DATA _{HIGH} limit on Channel 4. No violation if bit is set to 0.

CYCLE TIMER REGISTER

The cycle timer register is an 8-bit, read/write register that stores the conversion interval value for the automatic cycle interval mode of the AD7997/AD7998 (see the Modes of Operation section). D5 to D3 of the cycle timer register are unused and should contain 0s at all times. On power-up, the cycle timer register contains all 0s, thus disabling automatic cycle operation of the AD7997/AD7998. To enable automatic cycle mode, the user must write to the cycle timer register, selecting the required conversion interval by programming Bits D2 to D0. Table 23 shows the structure of the cycle timer register, while Table 24 shows how the bits in this register are decoded to provide various automatic sampling intervals.

Table 23. Cycle Timer Register and Defaults at Power-Up

D7	D6	D5	D4	D3	D2	D1	D0
Sample Delay	Bit Trial Delay	0	0	0	Cyc Bit2	Cyc Bit1	Cyc Bit0
0	0	0	0	0	0	0	0

Table 24. Cycle Timer Intervals

D2	D1	D0	Typical Conversion Interval (T _{CONVERT} = Conversion Time)
0	0	0	Mode Not Selected
0	0	1	T _{CONVERT} × 32
0	1	0	T _{CONVERT} × 64
0	1	1	T _{CONVERT} × 128
1	0	0	T _{CONVERT} × 256
1	0	1	T _{CONVERT} × 512
1	1	0	T _{CONVERT} × 1024
1	1	1	T _{CONVERT} × 2048

SAMPLE DELAY AND BIT TRIAL DELAY

It is recommended that no I²C bus activity occurs when a conversion is taking place. However, if this is not possible, for example when operating in Mode 2 or Mode 3, then in order to maintain the performance of the ADC, Bits D7 and D6 in the cycle timer register are used to delay critical sample intervals and bit trials from occurring while there is activity on the I²C bus. This results in a quiet period for each bit decision. In certain cases where there is excessive activity on the interface lines, this may have the effect of increasing the overall conversion time. However, if bit trial delays extend longer than 1 μs, the conversion terminates.

When Bits D7 and D6 are both 0, the bit trial and sample interval delaying mechanism is implemented. The default setting of D7 and D6 is 0. To turn off both delay mechanisms, set D7 and D6 to 1.

Table 25. Cycle Timer Register and Defaults at Power-up

D7	D6	D5	D4	D3	D2	D1	D0
Sample Delay	Bit Trial Delay	0	0	0	Cyc Bit 2	Cyc Bit 1	Cyc Bit 0
0	0	0	0	0	0	0	0

SERIAL INTERFACE

Control of the AD7997/AD7998 is carried out via the I²C-compatible serial bus. The devices are connected to this bus as slave devices under the control of a master device, such as the processor.

SERIAL BUS ADDRESS

Like all I²C-compatible devices, the AD7997/AD7998 have a 7-bit serial address. The 3 MSBs of this address for the AD7997/AD7998 are set to 010. The AD7997/AD7998 come in two versions, the AD7997-0/AD7997-0 and AD7997-1AD7998-1. The two versions have three different I²C addresses available, which are selected by either tying the address select pin, AS, to AGND or V_{DD}, or by letting the pin float (see Table 6). By giving different addresses for the two versions, up to five AD7997/AD7998 devices can be connected to a single serial bus, or the addresses can be set to avoid conflicts with other devices on the bus. (See Table 6.)

The serial bus protocol operates as follows.

The master initiates data transfer by establishing a start condition, defined as a high-to-low transition on the serial data line SDA, while the serial clock line, SCL, remains high. This indicates that an address/data stream follows. All slave peripherals connected to the serial bus responds to the start condition and shift in the next eight bits, consisting of a 7-bit address (MSB first) plus an R/ \overline{W} bit that determines the direction of the data transfer, that is, whether data is written to or read from the slave device.

The peripheral whose address corresponds to the transmitted address responds by pulling the data line low during the low period before the ninth clock pulse, known as the acknowledge bit. All other devices on the bus remain idle while the selected device waits for data to be read from or written to it. If the R/ \overline{W} bit is a 0, the master writes to the slave device. If the R/ \overline{W} bit is a 1, the master reads from the slave device.

Data is sent over the serial bus in sequences of nine clock pulses, eight bits of data followed by an acknowledge bit from the receiver of data. Transitions on the data line must occur during the low period of the clock signal and remain stable during the high period because a low-to-high transition when the clock is high may be interpreted as a stop signal.

When all data bytes have been read or written, stop conditions are established. In write mode, the master pulls the data line high during the 10th clock pulse to assert a stop condition. In read mode, the master device pulls the data line high during the low period before the ninth clock pulse. This is known as No Acknowledge. The master then takes the data line low during the low period before the 10th clock pulse, then high during the 10th clock pulse to assert a stop condition.

Any number of bytes of data may be transferred over the serial bus in one operation, but it is not possible to mix read and write in one operation, because the type of operation is determined at the beginning and cannot subsequently be changed without starting a new operation.

WRITING TO THE AD7997/AD7998

Depending on the register being written to, there are three different writes for the AD7997/AD7998.

WRITING TO THE ADDRESS POINTER REGISTER FOR A SUBSEQUENT READ

In order to read from a particular register, the address pointer register must first contain the address of that register. If it does not, the correct address must be written to the address pointer register by performing a single-byte write operation, as shown in Figure 26. The write operation consists of the serial bus address followed by the address pointer byte. No data is written to any of the data registers. A read operation may be subsequently performed to read the register of interest.

WRITING A SINGLE BYTE OF DATA TO THE ALERT STATUS REGISTER OR CYCLE REGISTER

The alert status register and cycle register are both 8-bit registers, so only one byte of data can be written to each. Writing a single byte of data to one of these registers consists of the serial bus write address, the chosen data register address written to the address pointer register, followed by the data byte written to the selected data register. See Figure 27.

WRITING TWO BYTES OF DATA TO A LIMIT, HYSTERESIS, OR CONFIGURATION REGISTER

Each of the four limit registers are 16-bit registers, so two bytes of data are required to write a value to any one of them. Writing two bytes of data to one of these registers consists of the serial bus write address, the chosen limit register address written to the address pointer register, followed by two data bytes written to the selected data register. See Figure 28.

If the master is write addressing the AD7997/AD7998, it can write to more than one register without readdressing the ADC. After the first write operation has completed for the first data register, during the next byte the master simply writes to the address pointer byte to select the next data register for a write operation. This eliminates the need to readdress the device in order to write to another data register.

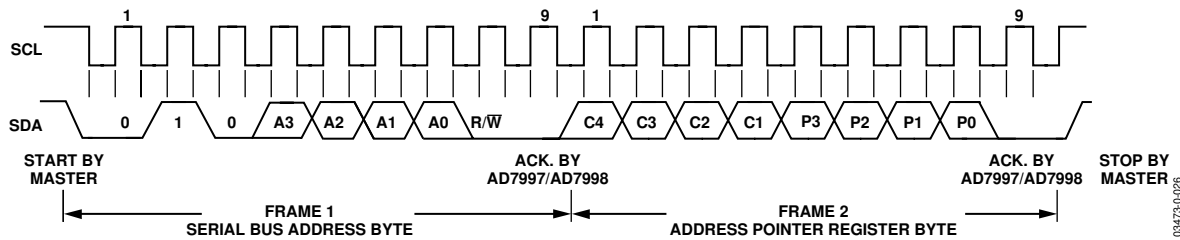

Figure 26. Writing to the Address Pointer Register to Select a Register for a Subsequent Read Operation

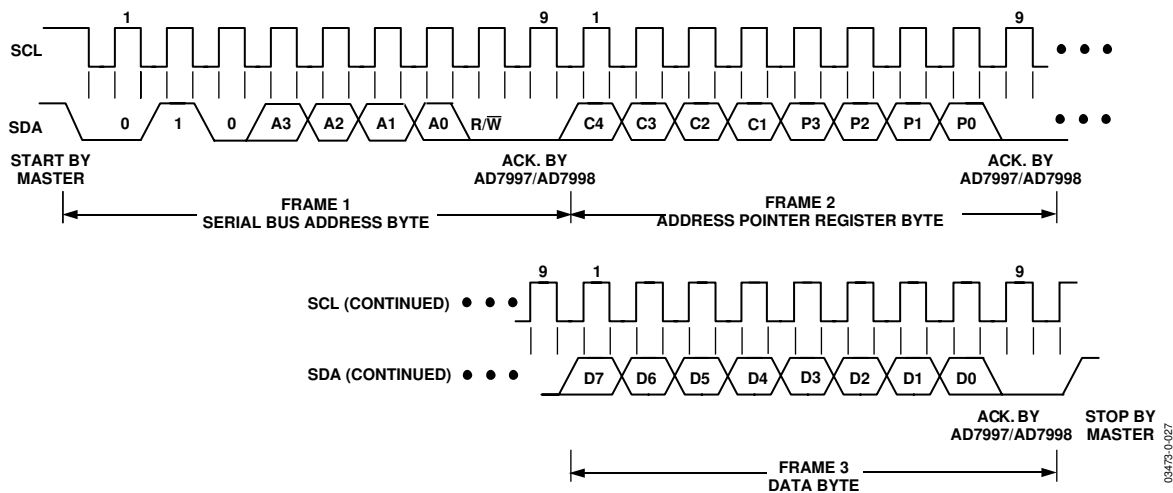

Figure 27. Single-Byte Write Sequence

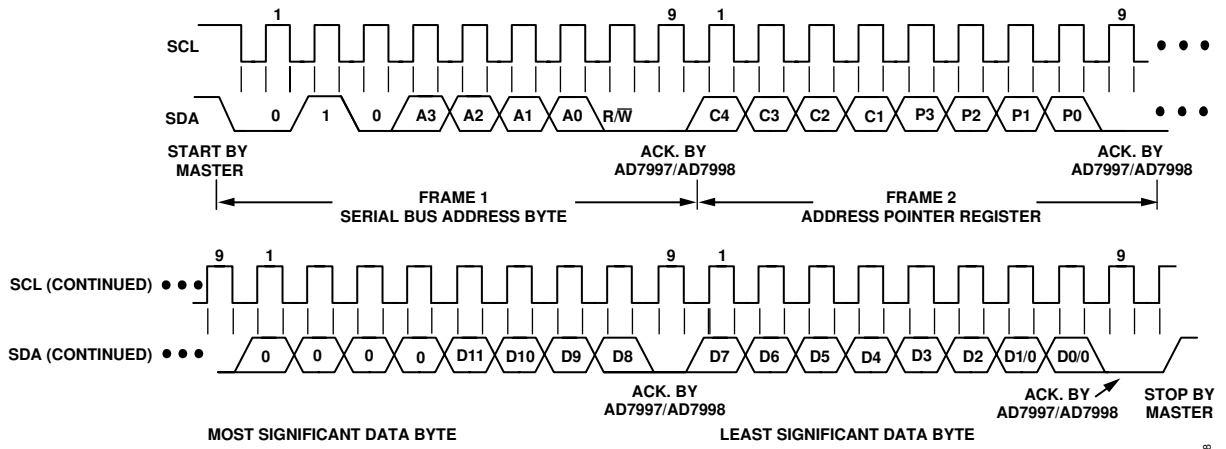

Figure 28. 2-Byte Write Sequence

08473-0-028

READING DATA FROM THE AD7997/AD7998

Reading data from the AD7997/AD7998 is a 1- or 2-byte operation. Reading back the contents of the alert status register or the cycle timer register is a single-byte read operation, as shown in Figure 29. This assumes the particular register address has previously been set up by a single-byte write operation to the address pointer register, as shown in Figure 26. Once the register address has been set up, any number of reads can be performed from that particular register without having to write to the address pointer register again.

If a read from a different register is required, the relevant register address has to be written to the address pointer register, and again any number of reads from this register may then be performed.

Reading data from the configuration register, conversion result register, DATA_{HIGH} registers, DATA_{LOW} registers, or hysteresis registers is a 2-byte operation, as shown in Figure 30. The same rules apply for a 2-byte read as a single-byte read.

When reading data back from a register, for example the conversion result register, if more than two read bytes are supplied, the same or new data is read from the AD7997/AD7998 without the need to readdress the device. This allows the master to continuously read from a data register without having to readdress the AD7997/AD7998.

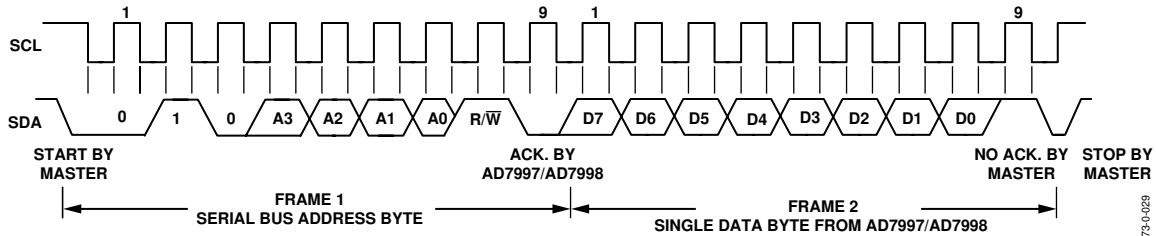

Figure 29. Reading a Single Byte of Data from a Selected Register

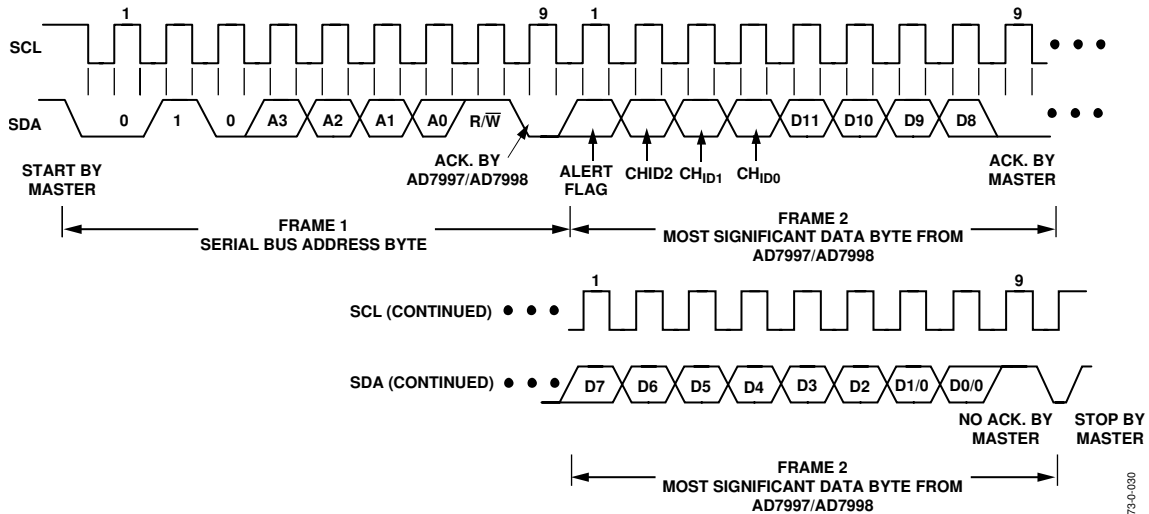

Figure 30. Reading Two Bytes of Data from the Conversion Result Register

ALERT/BUSY PIN

The ALERT/BUSY pin may be configured as an alert output or as a busy output, as shown in Table 12.

SMBus ALERT

The AD7997/AD7998 ALERT output is an SMBus interrupt line for devices that want to trade their ability to master for an extra pin. The AD7997/AD7998 is a slave-only device that uses the SMBus ALERT to signal the host device that it wants to talk. The SMBus ALERT on the AD7997/AD7998 is used as an out-of-range indicator (a limit violation indicator).

The ALERT pin has an open-drain configuration that allows the ALERT outputs of several AD7997/AD7998s to be wired-AND'ed together when the ALERT pin is active low. D0 of the configuration register is used to set the active polarity of the ALERT output. The power-up default is active low. The ALERT function can be enabled or disabled by setting D2 of the configuration register to 1 or 0, respectively.

The host device can process the alert interrupt and simultaneously access all SMBus alert devices through the alert response address. Only the device that pulled the alert low acknowledges the alert response address (ARA). If more than one device pulls the ALERT pin low, the highest priority (lowest address) device wins communication rights via standard I²C arbitration during the slave address transfer.

The ALERT output becomes active when the value in the conversion result register exceeds the value in the DATA_{HIGH} register or falls below the value in the DATA_{LOW} register for a selected channel. It is reset when a write operation to the configuration register sets D1 to a 1, or when the conversion result returns *N* LSB below or above the value stored in the DATA_{HIGH} register or the DATA_{LOW} register, respectively. *N* is the value in the hysteresis register (see the Limit Registers section).

The ALERT output requires an external pull-up resistor that can be connected to a voltage different from V_{DD} provided the maximum voltage rating of the ALERT output pin is not exceeded. The value of the pull-up resistor depends on the application, but should be as large as possible to avoid excessive sink currents at the ALERT output.

BUSY

When the ALERT/BUSY pin is configured as a BUSY output the pin is used to indicate when a conversion is taking place. The polarity of the BUSY pin is programmed through bit D0 in the Configuration register.

PLACING THE AD7997-1/AD7998-1 INTO HIGH SPEED MODE

High speed mode communication commences after the master addresses all devices connected to the bus with the master code, 00001XXX, to indicate that a high speed mode transfer is to begin. No device connected to the bus is allowed to acknowledge the high speed master code; therefore, the code is followed by a not-acknowledge (see Figure 31). The master must then issue a repeated start followed by the device address with an R/ \bar{W} bit. The selected device then acknowledges its address.

All devices continue to operate in high speed mode until such a time as the master issues a stop condition. When the stop condition is issued, the devices all return to fast mode.

THE ADDRESS SELECT (AS) PIN

The address select pin on the AD7997/AD7998 is used to set the I²C address for the AD7997/AD7998 device. The AS pin can be tied to V_{DD}, to AGND, or left floating. The selection should be made as close as possible to the AS pin; avoid having long tracks introducing extra capacitance on to the pin. This is important for the float selection, as the AS pin has to charge to a midpoint after the start bit during the first address byte. Extra capacitance on the AS pin increases the time taken to charge to the midpoint and may cause an incorrect decision on the device address. When the AS pin is left floating, the AD7997/AD7998 can work with a capacitive load up to 40 pF.

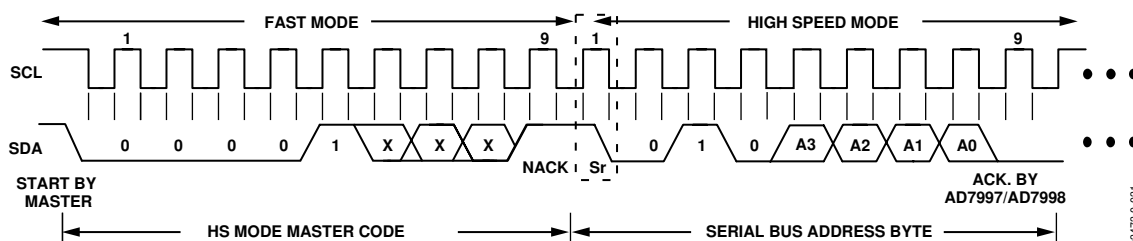

Figure 31. Placing the Part into High Speed Mode

MODES OF OPERATION

When supplies are first applied to the AD7997/AD7998, the ADC powers up in sleep mode and normally remains in this shutdown state while not converting. There are three methods of initiating a conversion on the AD7997/AD7998.

MODE 1—USING THE $\overline{\text{CONVST}}$ PIN

A conversion can be initiated on the AD7997/AD7998 by pulsing the $\overline{\text{CONVST}}$ signal. The conversion clock for the part is internally generated so no external clock is required, except when reading from or writing to the serial port. On the rising edge of $\overline{\text{CONVST}}$, the AD7997/AD7998 begins to power up (see point A in Figure 32). The power-up time from shutdown mode for the AD7997/AD7998 is approximately 1 μs ; the $\overline{\text{CONVST}}$ signal must remain high for 1 μs for the part to power up fully. $\overline{\text{CONVST}}$ can be brought low after this time. This power-up time also includes the acquisition time of the ADC. The falling edge of the $\overline{\text{CONVST}}$ signal places the track-and-hold into hold mode; a conversion is also initiated at this point (point B in Figure 32). When the conversion is complete, approximately 2 μs later, the part returns to shutdown (point C in Figure 32) and remains there until the next rising edge of $\overline{\text{CONVST}}$. The master can then read the ADC to obtain the conversion result. The address pointer register must be pointing to the conversion result register in order to read back the conversion result.

If the $\overline{\text{CONVST}}$ pulse does not remain high for more than 1 μs , the falling edge of $\overline{\text{CONVST}}$ still initiates a conversion but the result is invalid because the AD7997/AD7998 are not fully powered-up when the conversion takes place. To maintain the performance of the AD7997/AD7998 in this mode it is recommended that the I²C bus is quiet when a conversion is taking place.

The cycle timer register and Bits C4 to C1 in the address pointer register should contain all 0s when operating the AD7997/AD7998 in this mode. The $\overline{\text{CONVST}}$ pin should be tied low for all other modes of operation.

To select an analog input channel for conversion in this mode, the user must write to the configuration register and select the corresponding channel for conversion. To set up a sequence of channels to be converted with each $\overline{\text{CONVST}}$ pulse, set the corresponding channel bits in the configuration register (see Table 11).

Once a conversion is complete, the master can address the AD7997/AD7998 to read the conversion result. If further conversions are required, the SCL line can be taken high while the $\overline{\text{CONVST}}$ signal is pulsed again; then an additional 18 SCL pulses are required to read the conversion result.

When operating the AD7997-1/AD7998-1 in Mode 1 and reading after conversion with a 3.4 MHz f_{SCL} , the ADCs can achieve a typical throughput rate of up to 121 kSPS.

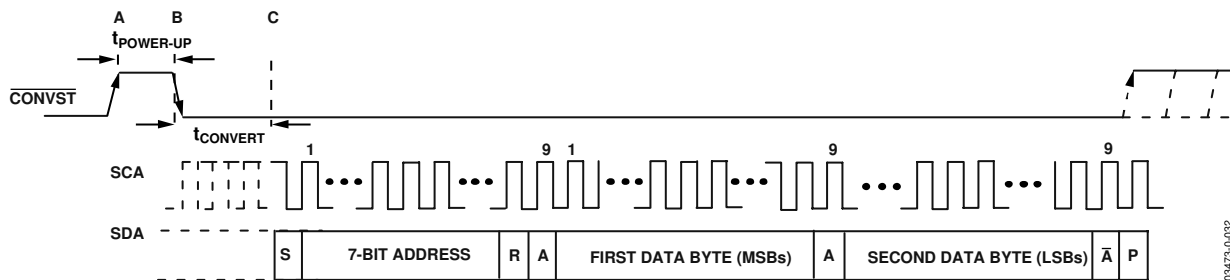

Figure 32. Mode 1 Operation

MODE 2 – COMMAND MODE

This mode allows a conversion to be automatically initiated any time a write operation occurs. In order to use this mode, the Command Bits C4 to C1 in the address pointer byte shown in Table 7 must be programmed.

To select a single analog input for conversion in this mode, the user must set Bits C4 to C1 of the address pointer byte to indicate which channel to convert on (see Table 26). When all four command bits are 0, this mode is not in use.

To select a sequence of channels for conversion in this mode, first select the channels to be included in the sequence by setting the channel bits in the configuration register. Next, set the command bits in the address pointer byte to 0111. With the command bits of the address pointer byte set to 0111, the ADC knows to look in the configuration register for the sequence of channels to be converted. The ADC starts converting on the lowest channel in the sequence and then the next lowest until all the channels in the sequence are converted. The ADC stops converting the sequence when it receives a STOP bit.

Figure 29 illustrates a 2-byte read operation from the conversion result register. This operation is preceded typically by a write to the address pointer register so that the following read accesses the desired register, in this case the conversion result register (see Figure 26). If Command Bits C4 to C1 are set when the contents of the address pointer register are being loaded, the AD7997/AD7998 begins to power up and convert upon the selected channel(s). Power-up begins on the fifth SCL falling edge of the address pointer byte, (see point A in Figure 33).

Table 26 shows the channel selection in this mode via Command Bits C4 to C1 in the address pointer register. The wake-up, acquisition, and conversion times combined should take approximately 3 μ s. Following the write operation, the AD7997/AD7998 must be addressed again to indicate that a read operation is required. The read then takes place from the conversion result register. This read accesses the conversion result from the channel selected via the command bits. If Command Bits C4 to C1 were set to 0111, and Bits D4 and D5 were set in the configuration register, a 4-byte read would be necessary. The first read accesses the data from the conversion on V_{IN1} . While this read takes place, a conversion occurs on V_{IN2} . The second read accesses this data from V_{IN2} . Figure 34 illustrates how this mode operates; the user would first have written to the configuration register to select the sequence of channels to be converted before write addressing the part with the command bits set to 0111.

When operating the AD7997-1/AD7998-1 in Mode 2 with a high speed mode, 3.4 MHz SCL, the conversion may not be complete before the master tries to read the conversion result. If this is the case, the AD7997-1/AD7998-1 holds the SCL line low during the ACK clock after the read address, until the conversion is complete. When the conversion is complete, the AD7997-1/AD7998-1 releases the SCL line and the master can then read the conversion result.

After the conversion is initiated by setting the command bits in the address pointer byte, if the AD7997/AD7998 receives a STOP or NACK from the master, the AD7997/AD7998 stops converting.

Table 26. Address Pointer Byte

C4	C3	C2	C1	P3	P2	P1	P0	Mode 2, Convert On	Comments
0	0	0	0	0	0	0	0	Not selected	
1	0	0	0	0	0	0	0	V_{IN1}	
1	0	0	1	0	0	0	0	V_{IN2}	
1	0	1	0	0	0	0	0	V_{IN3}	
1	0	1	1	0	0	0	0	V_{IN4}	
1	1	0	0	0	0	0	0	V_{IN5}	
1	1	0	1	0	0	0	0	V_{IN6}	
1	1	1	0	0	0	0	0	V_{IN7}	
1	1	1	1	0	0	0	0	V_{IN8}	
0	1	1	1	0	0	0	0	Sequence of channels selected in the configuration register, Bits D11 to D4.	With the pointer Bits P3–P0 set to all 0s, the next read accesses the results of the conversion result register.

AD7997/AD7998

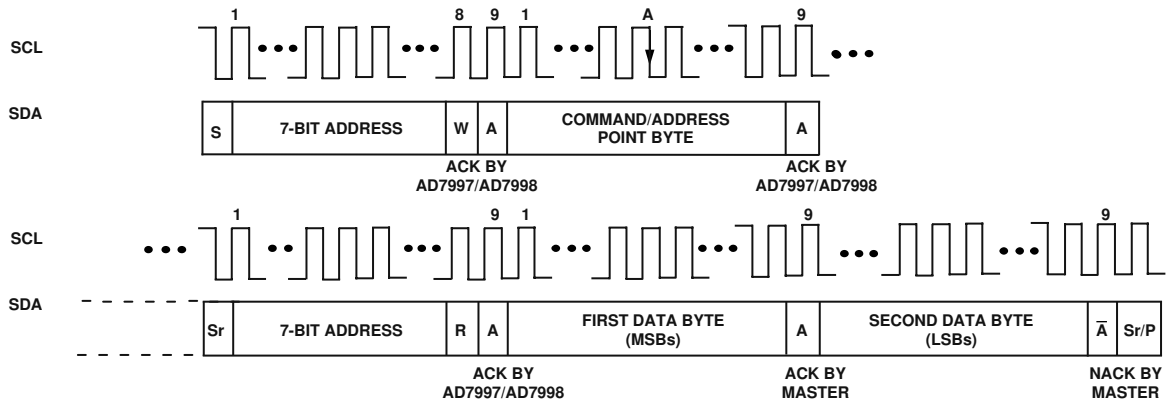

Figure 33. Mode 2 Operation

03473-0-033

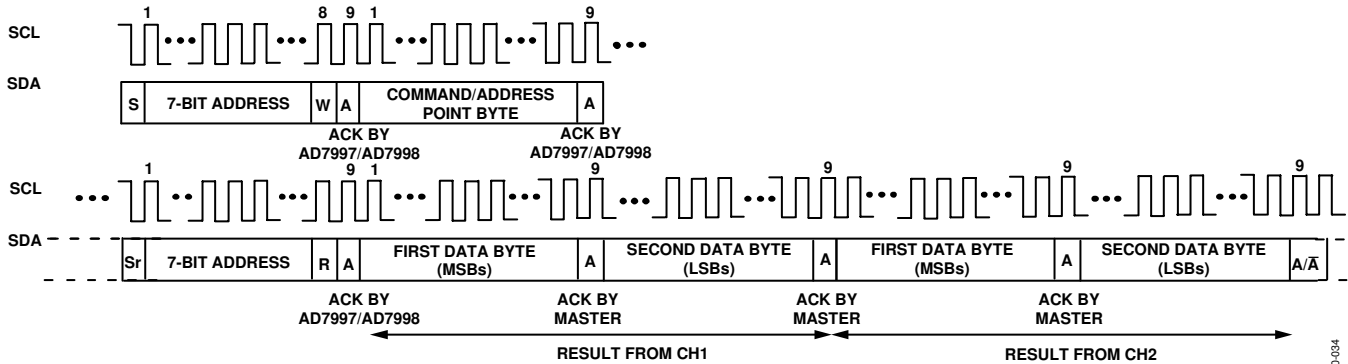

Figure 34. Mode 2 Sequence Operation

03473-0-034

MODE 3—AUTOMATIC CYCLE INTERVAL MODE

An automatic conversion cycle can be selected and enabled by writing a value to the cycle timer register. A conversion cycle interval can be set up on the AD7997/AD7998 by programming the relevant bits in the 8-bit cycle timer register, as decoded in Table 24. Only the 3 LSBs are used to select the cycle interval; the 5 MSBs should contain 0s. When the 3 LSBs of the register are programmed with any configuration other than all 0s, a conversion takes place every X ms; the cycle interval, X , depends on the configuration of these three bits in the cycle timer register. There are seven different cycle time intervals to choose from, as shown in Table 24. Once the conversion has taken place, the part powers down again until the next conversion occurs. To exit this mode of operation, the user must program the 3 LSBs of the cycle timer register to contain all 0s.

To select a channel(s) for operation in the cycle mode, set the corresponding channel bit(s), D11 to D4, of the configuration register. If more than one channel bit is set in the configuration register, the ADC automatically cycles through the channel sequence starting with the lowest channel and working its way up through the sequence. Once the sequence is complete, the ADC starts converting on the lowest channel again, continuing to loop through the sequence until the cycle timer register contents are set to all 0s. This mode is useful for monitoring signals, such as battery voltage and temperature, alerting only when the limits are violated.

OUTLINE DIMENSIONS

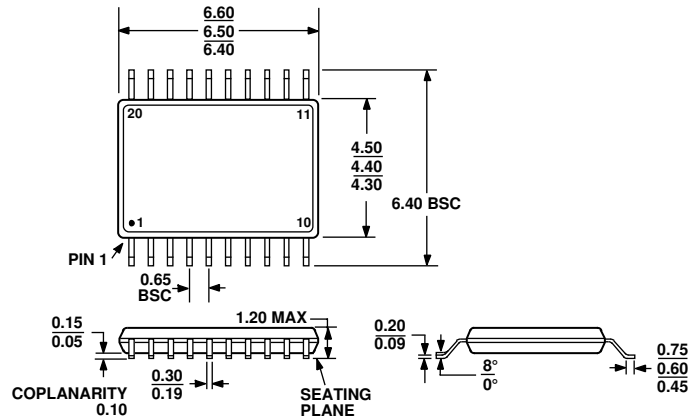

COMPLIANT TO JEDEC STANDARDS MO-153AC

Figure 35. 20-Lead Thin Shrink Small Outline Package [TSSOP]
(RU-20)

Dimensions shown in millimeters

ORDERING GUIDE

Model ¹	Temperature Range	Linearity Error ² (Max)	Package Option	Package Description
AD7997BRU-0	-40°C to +85°C	±0.5 LSB	RU-20	TSSOP
AD7997BRU-0REEL	-40°C to +85°C	±0.5 LSB	RU-20	TSSOP
AD7997BRUZ-0 ³	-40°C to +85°C	±0.5 LSB	RU-20	TSSOP
AD7997BRUZ-0REEL ³	-40°C to +85°C	±0.5 LSB	RU-20	TSSOP
AD7997BRU-1	-40°C to +85°C	±0.5 LSB	RU-20	TSSOP
AD7997BRU-1REEL	-40°C to +85°C	±0.5 LSB	RU-20	TSSOP
AD7997BRUZ-1 ³	-40°C to +85°C	±0.5 LSB	RU-20	TSSOP
AD7997BRUZ-1REEL ³	-40°C to +85°C	±0.5 LSB	RU-20	TSSOP
AD7998BRU-0	-40°C to +85°C	±1 LSB	RU-20	TSSOP
AD7998BRU-0REEL	-40°C to +85°C	±1 LSB	RU-20	TSSOP
AD7998BRUZ-0 ³	-40°C to +85°C	±1 LSB	RU-20	TSSOP
AD7998BRUZ-0REEL ³	-40°C to +85°C	±1 LSB	RU-20	TSSOP
AD7998BRU-1	-40°C to +85°C	±1 LSB	RU-20	TSSOP
AD7998BRU-1REEL	-40°C to +85°C	±1 LSB	RU-20	TSSOP
AD7998BRUZ-1 ³	-40°C to +85°C	±1 LSB	RU-20	TSSOP
AD7998BRUZ-1REEL ³	-40°C to +85°C	±1 LSB	RU-20	TSSOP
EVAL-AD7997CB				Standalone Evaluation Board
EVAL-AD7998CB				Standalone Evaluation Board

¹ The AD7997-0/AD7998-0 support standard and fast I²C interface modes. The AD7997-1/AD7998-1 support standard, fast, and high speed I²C interface modes.

² Linearity error here refers to integral nonlinearity.

³ Z = Pb-free part.

RELATED PARTS IN I²C-COMPATIBLE ADC PRODUCT FAMILY

Part Number	Resolution	Number of Input Channels	Package
AD7994	12	4	16 TSSOP
AD7993	10	4	16 TSSOP
AD7992	12	2	10 MSOP

AD7997/AD7998

NOTES

Purchase of licensed I²C components of Analog Devices or one of its sublicensed Associated Companies conveys a license for the purchaser under the Philips I²C Patent Rights to use these components in an I²C system, provided that the system conforms to the I²C Standard Specification as defined by Philips.

© 2004 Analog Devices, Inc. All rights reserved. Trademarks and registered trademarks are the property of their respective owners.
D03473-0-9/04(0)



www.analog.com