

NOTES:

1. MATERIALS AND FINISHES:

- BODY - STAINLESS STEEL, GOLD PLATED (.000030" MIN) OVER NICKEL (.000100" MIN).
- COUPLING NUT - STAINLESS STEEL, PASSIVATED
- CONTACT - BRASS, GOLD PLATED (.000030" MIN) OVER NICKEL (.000080" MIN).
- INSULATOR - PTFE, NATURAL
- GASKET - SILICONE RUBBER, RED
- RETAINING RING - SUS 304, NATURAL

2. ELECTRICAL:

- A. IMPEDANCE: 50 OHM
- B. FREQUENCY RANGE: DC - 22 GHz
- C. VSWR: 1.05 + .007f (GHz), MAX.
- D. D.W.V: 1000 VRMS, MIN.

3. MECHANICAL:

- A. DURABILITY: 500 CYCLES MIN.
- B. TEMPERATURE RANGE: -65°C TO +165°C

4. SINGLE PACK CONNECTOR IN ANTI-STATIC BAG.  
MARK BAG: AMPHENOL RF, 901-9201-2ASF-T, DATE CODE

THIRD ANGLE PROJ.

REVISIONS

REV	DESCRIPTION	DATE	ECN	APPR
A	RELEASE TO MFG.	07-Nov-15	50853	BCG
B	CHANGE TO SOLDER BARREL BODY	01-Jul-19	12047	SH

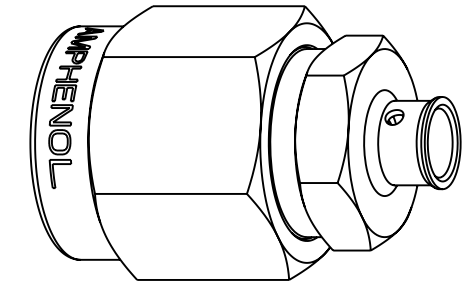
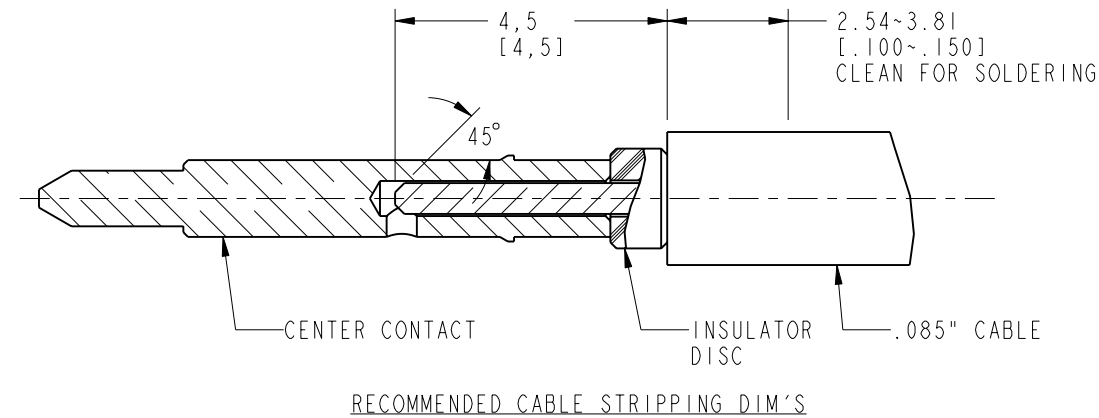

SCALE 4.000

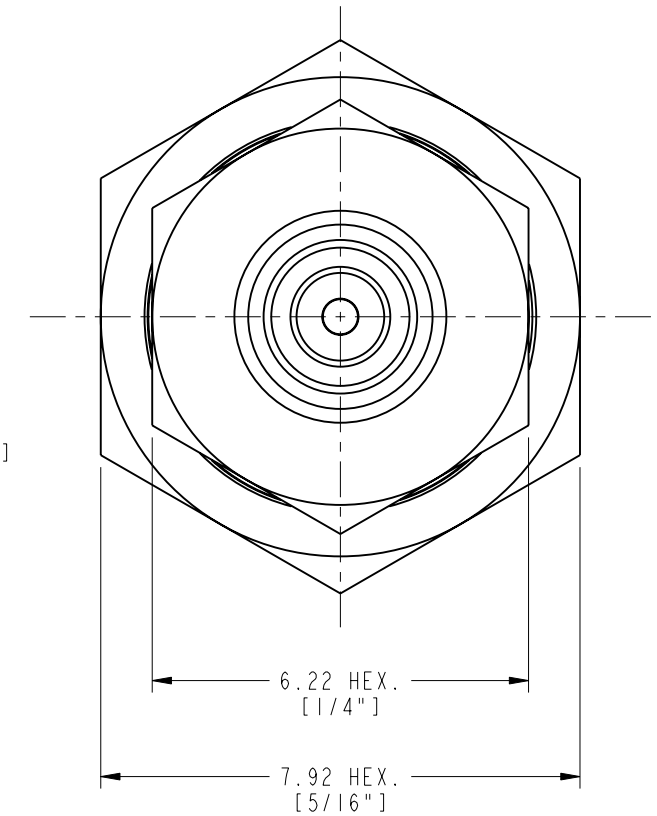
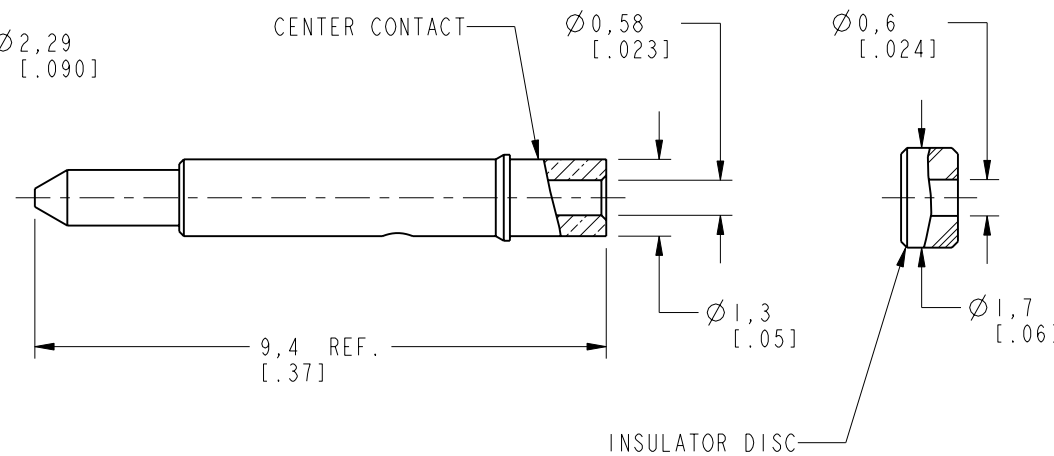
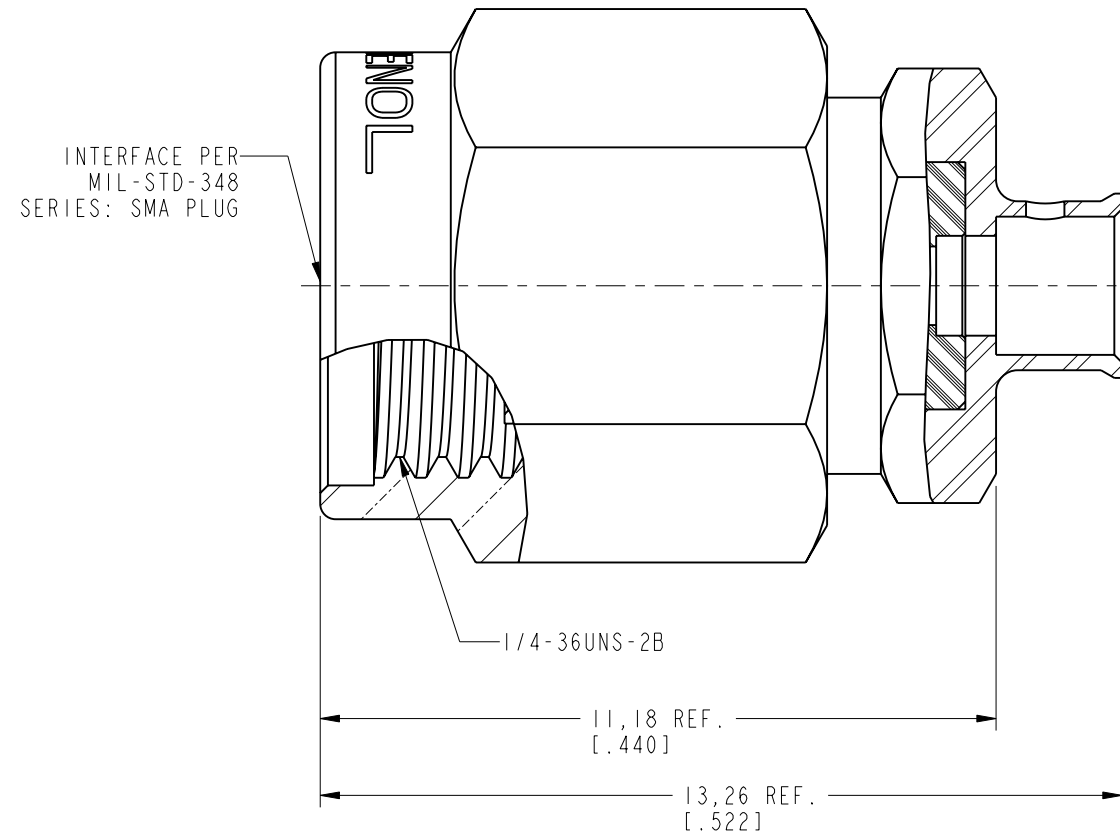

**CUSTOMER OUTLINE DRAWING**

ALL OTHER SHEETS ARE FOR INTERNAL USE ONLY

UNLESS OTHERWISE SPECIFIED, DIMENSIONS ARE IN METRIC AND TOLERANCES ARE:  
 <0.5mm ±0.05mm    0.5 - 6mm ±0.1mm    6 - 30mm ±0.2mm    30 - 120mm ±0.3mm    ANGLES ±1°

NOTICE - These drawings, specifications, or other data (1) are, and remain the property of Amphenol corp. (2) must be returned upon request; and (3) are confidential and not to be disclosed to any person other than those to whom they are given by Amphenol Corp. the furnishing of these drawings, specifications, or other data by Amphenol Corp., or to any other person to anyone for any purpose is not to be regarded by implication or otherwise in any manner licensing, granting rights to permitting such holder or any other person to manufacture, use or sell any product, process or design, patented or otherwise, that may in any way be related to or disclosed by said drawings, specifications, or other data.

MATERIAL	-
REFERENCE	EAR# 6826.1
REF:	901-9201-2ASF
CONFIGURATION LEVEL:	In Work
FINISH	

DRAWN	M. ZHANG	DATE	01-Jul-19
ENGINEER	B.C. GLEISSNER	DATE	17-Jul-15
APPROVED	S.HSIEH	DATE	01-Jul-19
CAD FILE			

TITLE		SMA SOLDER PLUG, WITH ANTI-TORQUE BODY (FOR .085" CABLE)	
SCALE: 8.0:1.0		SHEET 2 OF 2	
DWG SIZE	B	REV	B

Amphenol RF	
www.amphenolrf.com	
DRAWING NO.	901-9201-2ASF-T
ITEM NO.	901-9201-2ASF-T
PART NO.	901-9201-2ASF-T