

THIS DRAWING IS A CONTROLLED DOCUMENT. 466610

PART NUMBER	REV	FIRST USED
466610-1	K	854400-1
466610-2	K	565435-5

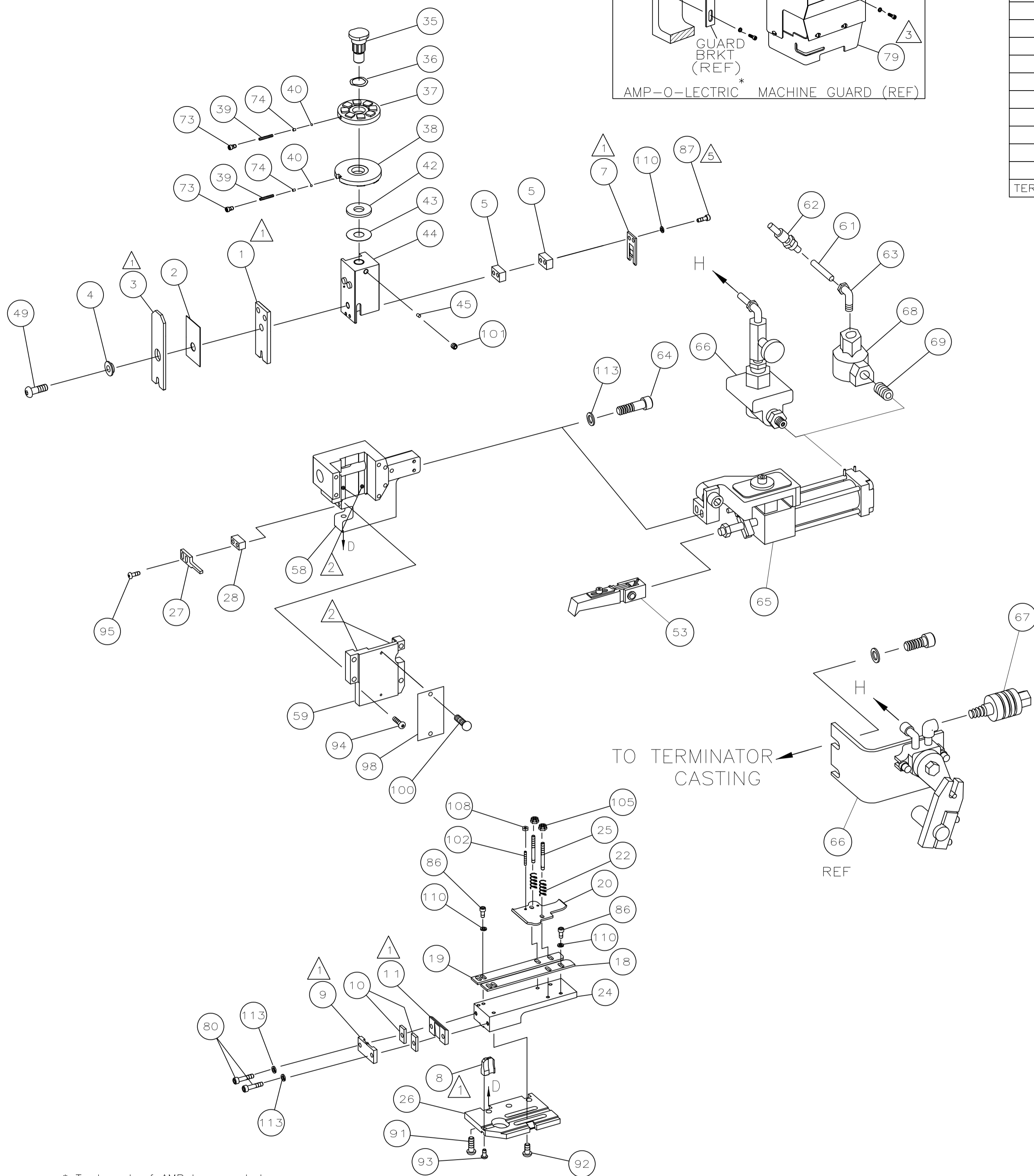
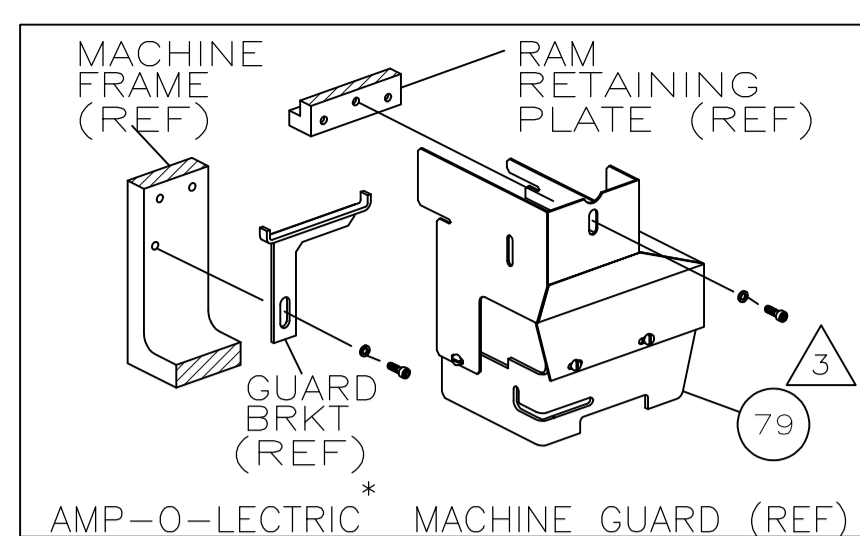

- ① RECOMMENDED SPARE PARTS.
- ② GREASE LIGHTLY.
- ③ GUARD MUST BE IN PLACE WHEN OPERATING APPLICATOR IN AMP-O-LECTRIC MACHINE.
- ④ SEE DRAWING FOR COMPONENTS
- ⑤ CUT TO LENGTH AT ASSY.

TERMINAL NAME:		CRIMPING DATA	
GROUNDING RING	61359-1	PAD LTR	CRIMP HEIGHT
		A	.095 ±.002
		B	.088 ±.002
		C	.083 ±.002
		D	NOT USED
		CRIMP	SIZE
		WIRE	.130
		INSUL	.180
		FEED	1.250
		APPL INST	A18039
		SET UP GAGE	458638-1
		LAYOUT	910
		WIRE STRIP LENGTH .173-.203	
		-1	LEADMAKER
		-2	AMP-O-LECTRIC
TERM APPL SPEC	114-2084		AIRFEED

QTY	REQD	PER ASSY	PART NO	DESCRIPTION	ITEM NO	
					129	
					128	
					127	
					126	
					125	
					124	
					123	
					122	
					121	
					120	
					119	
					118	
					117	
					116	
					115	
					114	
4	4	-	21024-5	WASHER,LOCK(NO.10)SHEAR PL	113	
					112	
					111	
6	6	-	21024-4	WASHER,LOCK(NO.8)SHEAR BL	110	
					109	
2	2	-	21018-4	NUT,HEX(4-40)DRAG	108	
					107	
					106	
2	2	-	21022-2	NUT,HEX SL(8-32)DRAG STUD	105	
					104	
					103	
2	2	-	4-21078-8	SKT SKT SET (4-40x.75)DRAG	102	
1	1	-	21009-2	SCR,SKT SET(1/4-20x.25)RAM	101	
2	2	-	21017-2	SCR,DRIVE(#2x.19)ID PLATE	100	
					99	
1	1	-	461264-1	PLATE, IDENTIFICATION	98	
					97	
					96	
2	2	-	2-21002-2	SCR,BHC(8-32x.50)STRIPPER	95	
4	4	-	2-21002-9	SCR,BHC(10-32x.75)CAP	94	
1	1	-	22733-8	SCR,BHC(8-32x.38 LW)ANVIL	93	
4	4	-	3-21002-3	SCR,BHC(1/4-20x.50)ST GD PL	92	
3	3	-	2-22733-8	SCR,BHC(1/4-20x.62)HSG	91	
					90	
					89	
					88	
⑤	2	2	-	3-21000-1	SCR,SHC(8-32x.97)SLUG BLADE	87
	4	4	-	2-21000-7	SCR,SHC(8-32x.50)STRIP GUIDE	86
					85	
					84	
					83	
					82	
					81	
③	2	2	-	3-21000-8	SCR,SKT CAP(10-32x.88)SH PL	80
	1	-	-	455750-8	GUARD ASSY	79
					78	
					77	
					76	
					75	
					74	
2	2	-	690603-1	SPRING, ASSIST	73	
2	2	-	23030-1	SCR,SKT CAP(6-32x.25)CP DSC	72	
					71	
					70	
-2	-1	U/M	PART NO	DESCRIPTION	ITEM NO	

QTY	REQD	PER ASSY	PART NO	DESCRIPTION	ITEM NO	
					70	
					69	
					68	
					67	
					66	
					65	
					64	
					63	
					62	
					61	
					60	
					59	
					58	
					57	
					56	
					55	
					54	
④	1	1	-	460680-1	FEED FINGER ASSY	53
					52	
					51	
					50	
					49	
1	1	-	7-21002-9	BOLT, CRIMPER(5/16-24x1.00)	48	
					47	
					46	
1	1	-	690191-1	PLUG, NYLON	45	
1	1	-	458266-1	RAM	44	
1	1	-	690125-1	WASHER, LAMINATED	43	
1	1	-	690124-1	WASHER, RAM	42	
					41	
2	2	-	23241-6	BALL, STEEL	40	
2	2	-	690170-1	SPRING, COMPRESSION	39	
1	1	-	690142-1	DISC, INSULATION	38	
1	1	-	2-690692-2	DISC, WIRE	37	
1	1	-	22480-5	WASHER, SPRING	36	
1	1	-	690212-1	POST, RAM	35	
					34	
					33	
					32	
					31	
					30	
					29	
1	1	-	3-690451-2	SPACER, STRIPPER	28	
1	1	-	458265-1	STRIPPER	27	
1	1	-	463915-2	PLATE, BASE	26	
2	2	-	22354-8	DRAG, STUD	25	
1	1	-	463903-2	PLATE, STRIP GUIDE	24	
					23	
2	2	-	4-22281-1	SPRING, DRAG	22	
					21	
1	1	-	454177-2	DRAG, STOCK	20	
1	1	-	3-458030-1	GUIDE, STRIP (REAR)	19	
1	1	-	3-458031-1	GUIDE, STRIP (FRONT)	18	
					17	
					16	
					15	
					14	
					13	
					12	
①	1	1	-	463914-1	PLATE, REAR SHEAR	11
	2	2	-	240645-9	SPACER, SHEAR PLATE	10
①	1	1	-	463913-1	PLATE, FRONT SHEAR	9
	1	1	-	7-238005-3	ANVIL	8
	1	1	-	1-238074-5	BLADE, SLUG	7
					6	
					5	
					4	
①	1	1	-	5-238075-6	SPACER, SLUG BLADE	3
	1	1	-	238009-1	SPACER, BLOCK CRIMPER	2
①	1	1	-	464113-1	CRIMPER, INSULATION	1
	1	1	-	455888-5	SPACER, CRIMPER	1
①	1	1	-	464112-1	CRIMPER, WIRE	1
-2	-1	U/M	PART NO	DESCRIPTION	ITEM NO	

THIS INFORMATION IS CONFIDENTIAL AND PROPRIETARY TO TYCO ELECTRONICS CORPORATION AND ITS WORLDWIDE SUBSIDIARIES AND AFFILIATES. IT MAY NOT BE DISCLOSED TO ANY OTHER PERSON OR ENTITY WITHOUT THE WRITTEN AUTHORIZATION OF TYCO ELECTRONICS CORPORATION, HARRISBURG, PENNSYLVANIA, USA.

LOC A  
DIST 66

REVISION RECORD	DATE	OWN	APVD	SCALE	SIZE	DRAWING NO	SHEET	REV
K ECR-10-019397	9-2010	MY	GB	-	A1	466610	1 of 1	K

DWN	J.HERRINGTON	2/25/93	MATERIAL	-	HEAT TREAT	-
CHK	C. ERISMAN	3-1-93				
APVD	B. WOLFE	3-1-93				

END FEED HDM APPLICATOR

3308-8 (1/98)

CUSTOMER ACCESSIBLE PRODUCTION DRAWING