



QUICKSWITCH® PRODUCTS

HIGH-SPEED CMOS QUICKSWITCH

16:8 MULTIPLEXER

IDTQS3390

FEATURES:

- Enhanced N channel FET with no inherent diode to Vcc
- 16:8 multiplexer function with zero delay
- 5Ω bidirectional switches connect inputs to outputs
- Zero propagation delay, zero ground bounce
- Low power CMOS proprietary technology
- Undershoot clamp diodes on all switch and control inputs
- Direct bidirectional connection for mux, demux
- Available in SOIC and QSOP packages

APPLICATIONS:

- Video, audio, graphics switching, muxing
- Hot-swapping, hot-docking
- Voltage translation (5V to 3.3V)

DESCRIPTION:

The QS3390 provides a 16:8 multiplexer logic switch. The low ON resistance (5Ω) of the QS3390 allows inputs to be connected to the outputs without adding propagation delay and without generating additional ground bounce noise.

Mux/Demux devices provide an order of magnitude faster speed than equivalent logic devices.

The QS3390 is characterized for operation at -40°C to +85°C.

FUNCTIONAL BLOCK DIAGRAM

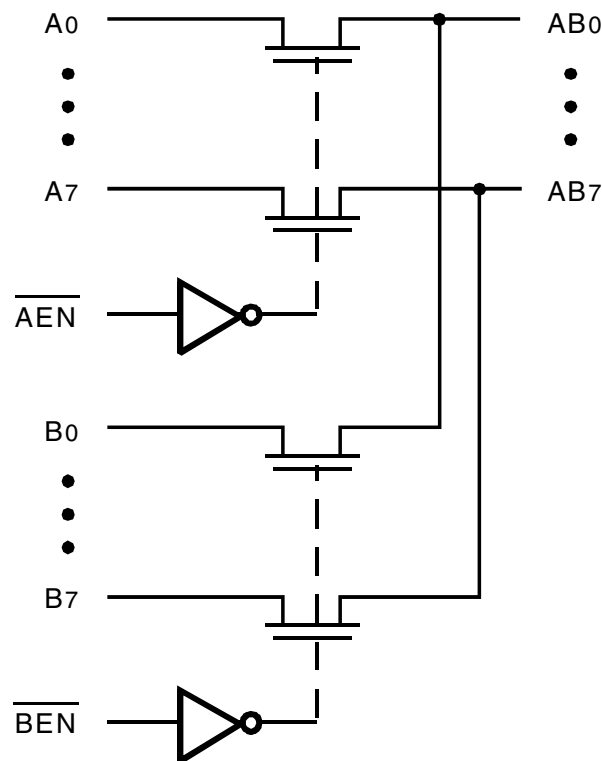

PIN CONFIGURATION

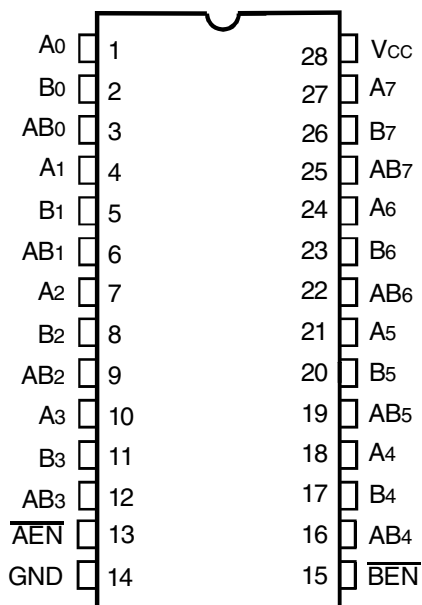

SOIC/ QSOP/ TSSOP
TOP VIEW

ABSOLUTE MAXIMUM RATINGS⁽¹⁾

Symbol	Description	Max	Unit
VTERM ⁽²⁾	Supply Voltage to Ground	-0.5 to +7	V
VTERM ⁽³⁾	DC Switch Voltage V _s	-0.5 to +7	V
VTERM ⁽³⁾	DC Input Voltage V _{IN}	-0.5 to +7	V
VAC	AC Input Voltage (pulse width ≤20ns)	-3	V
I _{OUT}	DC Output Current	120	mA
P _{MAX}	Maximum Power Dissipation (T _A = 85°C)	0.5	W
T _{STG}	Storage Temperature	-65 to +150	°C

NOTES:

- Stresses greater than those listed under ABSOLUTE MAXIMUM RATINGS may cause permanent damage to the device. This is a stress rating only and functional operation of the device at these or any other conditions above those indicated in the operational sections of this specification is not implied. Exposure to absolute maximum rating conditions for extended periods may affect reliability.
- V_{CC} terminals.
- All terminals except V_{CC}.

CAPACITANCE (T_A = +25°C, f = 1MHz, V_{IN} = 0V, V_{OUT} = 0V)

Pins		Typ.	Max. ⁽¹⁾	Unit
Control Inputs		4	5	pF
Quickswitch Channels	Demux	5	7	pF
(Switch OFF)	Mux	9	10	

NOTE:

- This parameter is guaranteed but not production tested.

PIN DESCRIPTION

Pin Names	I/O	Description
A ₀ - A ₉	I/O	Bus A
B ₀ - B ₉	I/O	Bus B
\overline{AEN} , \overline{BEN}	I	Bus Switch Enable

FUNCTION TABLE⁽¹⁾

\overline{AEN}	\overline{BEN}	A ₀ - A ₉	B ₀ - B ₉	Function
H	H	Off	Off	Disconnect
L	H	On	Off	A to AB
H	L	Off	On	B to AB
L	L	On	On	A, B to AB

NOTE:

- H = HIGH Voltage Level
L = LOW Voltage Level

DC ELECTRICAL CHARACTERISTICS OVER OPERATING RANGE

Following Conditions Apply Unless Otherwise Specified:

Industrial: $T_A = -40^{\circ}\text{C}$ to $+85^{\circ}\text{C}$, $V_{CC} = 5\text{V} \pm 5\%$

Symbol	Parameter	Test Conditions	Min.	Typ. ⁽¹⁾	Max.	Unit
V_{IH}	Input HIGH Voltage	Guaranteed Logic HIGH for Control Pins	2	—	—	V
V_{IL}	Input LOW Voltage	Guaranteed Logic LOW for Control Pins	—	—	0.8	V
I_{IN}	Input Leakage Current (Control Inputs)	$0\text{V} \leq V_{IN} \leq V_{CC}$	—	—	± 1	μA
I_{OZ}	Off-State Current (Hi-Z)	$0\text{V} \leq V_{OUT} \leq V_{CC}$	—	—	± 1	μA
RON	Switch ON Resistance	$V_{CC} = \text{Min.}, V_{IN} = 0\text{V}, I_{ON} = 30\text{mA}$	—	5	7	Ω
		$V_{CC} = \text{Min.}, V_{IN} = 2.4\text{V}, I_{ON} = 15\text{mA}$	—	10	15	
V_P	Pass Voltage ⁽²⁾	$V_{IN} = V_{CC} = 5\text{V}, I_{OUT} = -5\mu\text{A}$	3.7	4	4.2	V

NOTES:

1. Typical values are at $V_{CC} = 5\text{V}$ and $T_A = 25^{\circ}\text{C}$.
2. Pass voltage is guaranteed but not production tested.

TYPICAL ON RESISTANCE vs V_{IN} AT $V_{CC} = 5\text{V}$

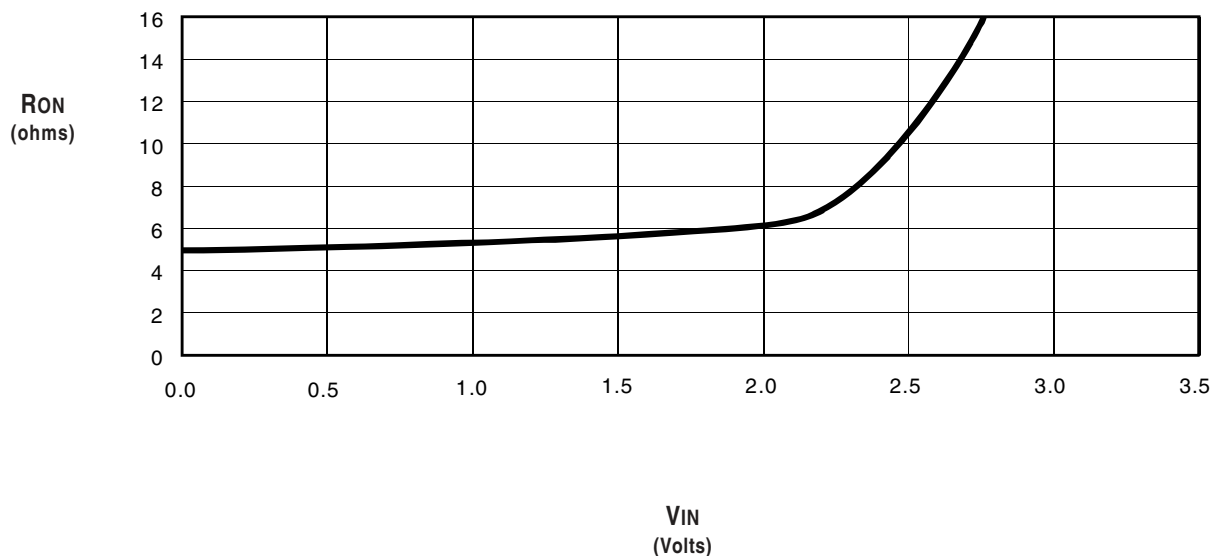

POWER SUPPLY CHARACTERISTICS

Symbol	Parameter	Test Conditions ⁽¹⁾	Max.	Unit
I _{CCQ}	Quiescent Power Supply Current	V _{CC} = Max., V _{IN} = GND or V _{CC} , f = 0	3	μA
ΔI _{CC}	Power Supply Current per Input HIGH ⁽²⁾	V _{CC} = Max., V _{IN} = 3.4V, f = 0	1.5	mA
I _{CCD}	Dynamic Power Supply Current per MHz ⁽³⁾	V _{CC} = Max., A, B, and AB Pins Open, Control Inputs Toggling @ 50% Duty Cycle	0.25	mA/MHz

NOTES:

- For conditions shown as Min. or Max., use the appropriate values specified under DC Electrical Characteristics.
- Per TTL-driven input (V_{IN} = 3.4V, control inputs only). A, B, and AB pins do not contribute to ΔI_{CC}.
- This current applies to the control inputs only and represents the current required to switch internal capacitance at the specified frequency. The A, B, and AB inputs generate no significant AC or DC currents as they transition. This parameter is guaranteed but not production tested.

SWITCHING CHARACTERISTICS OVER OPERATING RANGE

T_A = -40°C to +85°C, V_{CC} = 5V ± 5%

C_{LOAD} = 50pF, R_{LOAD} = 500Ω unless otherwise noted.

Symbol	Parameter	Min. ⁽¹⁾	Typ.	Max.	Unit
t _{PLH} t _{PHL}	Data Propagation Delay ⁽²⁾ A, B, to/from AB	—	—	0.25 ⁽³⁾	ns
t _{PZL} t _{PZH}	Switch Turn-On Delay AEN, BEN to A, B, AB	1.5	—	6.5	ns
t _{PLZ} t _{PHZ}	Switch Turn-Off Delay ⁽²⁾ AEN, BEN to A, B, AB	1.5	—	5.5	ns

NOTES:

- Minimums are guaranteed but not production tested.
- This parameter is guaranteed but not production tested.
- The bus switch contributes no propagation delay other than the RC delay of the ON resistance of the switch and the load capacitance. The time constant for the switch alone is of the order of 0.25ns at C_L = 50pF. Since this time constant is much smaller than the rise and fall times of typical driving signals, it adds very little propagation delay to the system. Propagation delay of the bus switch, when used in a system, is determined by the driving circuit on the driving side of the switch and its interaction with the load on the driven side.

ORDERING INFORMATION

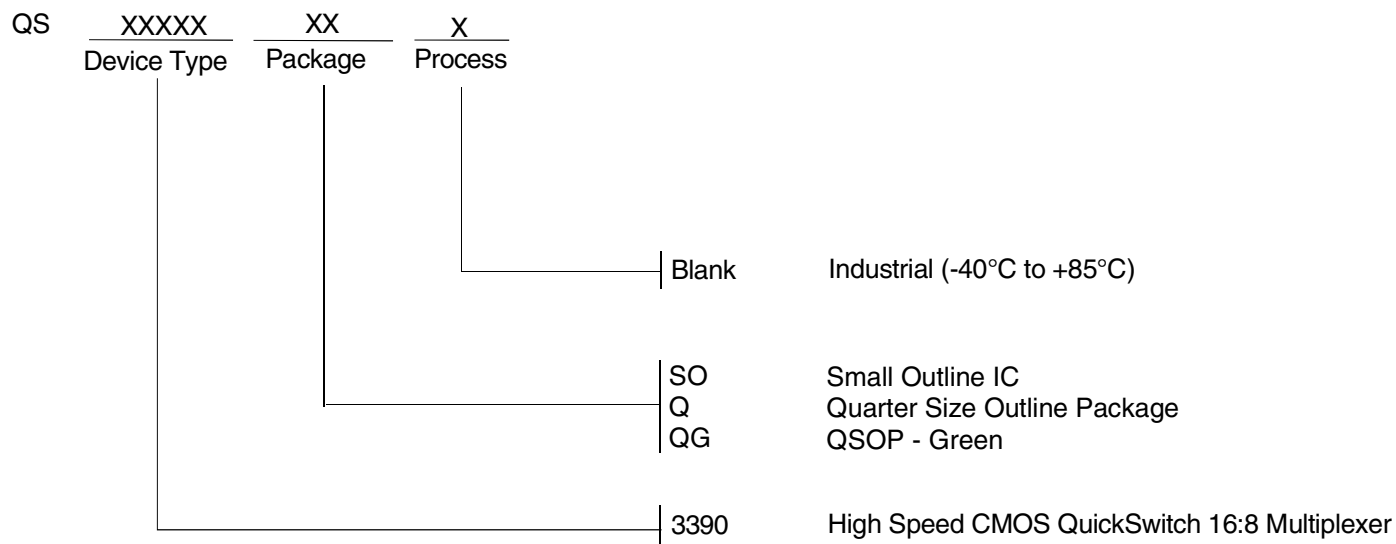

CORPORATE HEADQUARTERS
6024 Silver Creek Valley Road
San Jose, CA 95138

for SALES:
800-345-7015 or 408-284-8200
fax: 408-284-2775
www.idt.com

for Tech Support:
logichelp@idt.com