

Power supply evaluation board for LNB based on the LNBH26LS

Data brief

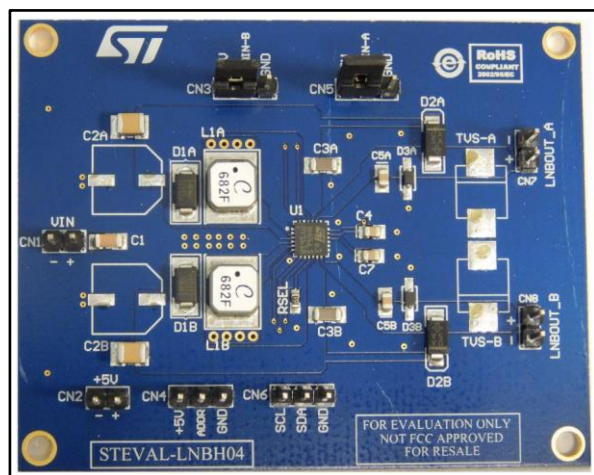

Description

This evaluation board implements a DC-DC converter based on the LNBH26LS device. It is used to power LNBs inside dish antennas to receive satellite TV signals.

The LNBH26LS is an integrated solution for supplying and interfacing satellite LNB modules in accordance with international standards. This simple and complete solution for dual tuner satellite receivers offers high performance at low cost and low external component count.

The LNBH26LS evaluation board includes an I²C bus interface and the internal 22 kHz tone generator which is factory trimmed and can be controlled by the DSQIN pin (TTL compatible), allowing immediate DiSEqC™ data encoding.

Thanks to a fully integrated step-up DC-DC converter, it functions with a single input voltage supply source ranging from 8 V to 16 V.

Features

- Complete interface between LNB and I²C bus
- Built-in DC-DC converter for single 12 V supply operation and high efficiency (typ. 93% @ 0.5 A)
- Selectable output current limit by external resistor
- Compliant with the output voltage specifications of principal satellite receivers (15 programmable levels)
- Accurate built-in 22 kHz tone generator suits widely accepted standards
- 22 kHz tone waveform integrity guaranteed also at no load condition
- Low drop post regulator and high efficiency step-up PWM with integrated power N-MOS allowing low power losses
- LPM function (low power mode) to reduce dissipation
- Overload and overtemperature internal protection with I²C diagnostic bits
- LNB short-circuit dynamic protection
- ± 4 kV ESD tolerant on output power pins
- RoHS compliant

1 Schematic diagram

Figure 1: STEVAL-LNBH04 circuit schematic

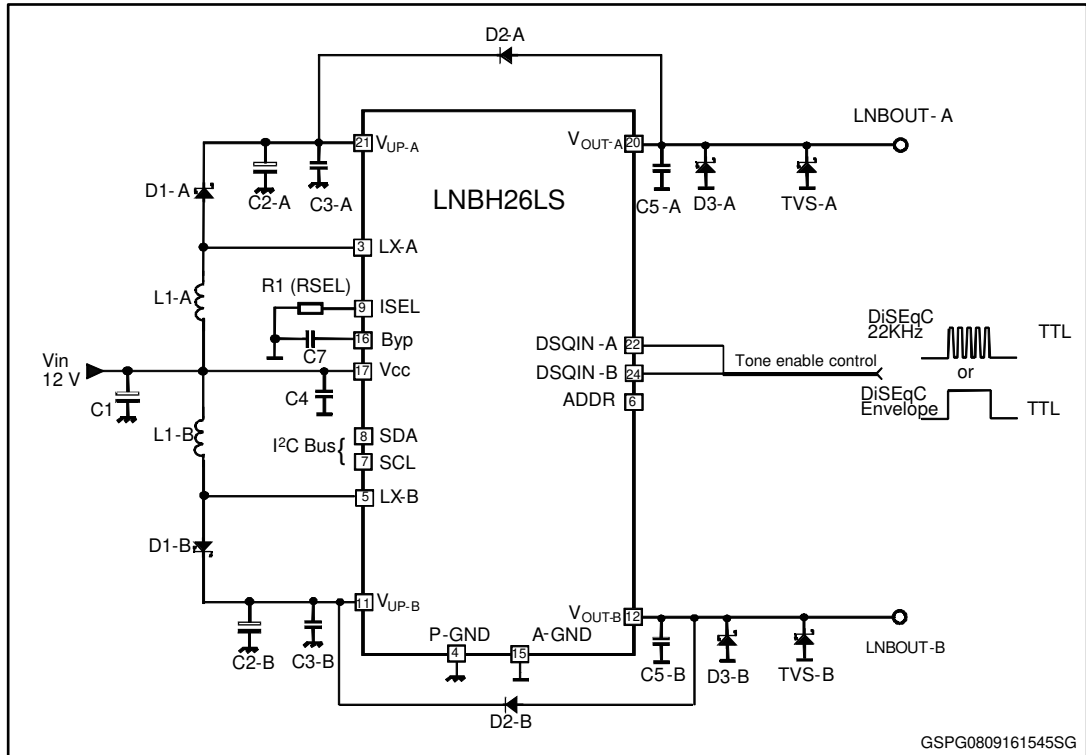

2 Revision history

Table 1: Document revision history

Date	Version	Changes
19-Sep-2016	1	Initial release.

IMPORTANT NOTICE – PLEASE READ CAREFULLY

STMicroelectronics NV and its subsidiaries ("ST") reserve the right to make changes, corrections, enhancements, modifications, and improvements to ST products and/or to this document at any time without notice. Purchasers should obtain the latest relevant information on ST products before placing orders. ST products are sold pursuant to ST's terms and conditions of sale in place at the time of order acknowledgement.

Purchasers are solely responsible for the choice, selection, and use of ST products and ST assumes no liability for application assistance or the design of Purchasers' products.

No license, express or implied, to any intellectual property right is granted by ST herein.

Resale of ST products with provisions different from the information set forth herein shall void any warranty granted by ST for such product.

ST and the ST logo are trademarks of ST. All other product or service names are the property of their respective owners.

Information in this document supersedes and replaces information previously supplied in any prior versions of this document.

© 2016 STMicroelectronics – All rights reserved