



Low ADEV OCXO Series

VCOCXO: OH320-LA-71003CV
VCOCXO: OH320-LA-61003CV
OCXO: OH320-LA-61003CF

CONNOR WINFIELD



2111 Comprehensive Drive

Aurora, Illinois 60505

Phone: 630-851-4722

Fax: 630-851-5040

www.conwin.com

Description:

Connor-Winfield's OH320-LA-series is a 3.3Vdc LVC MOS OCXO series with very low Allan Deviation (ADEV). These devices are available as VCOCXO or fixed OCXO, and packaged in a 22x25.4mm surface mount footprint.



Features:

- Output Frequency: 10.0 or 12.8 MHz
- 3.3 Vdc Operation
- 22 x 25.4 mm SMT Package
- Frequency Stability: ± 10 ppb
- Temperature Range: -20 to 70°C or -40 to 85°C
- LVC MOS Output
- Grounded Metal Cover
- RoHS Compliant / Lead Free

Absolute Maximum Ratings

Parameter	Minimum	Nominal	Maximum	Units	Notes
Storage Temperature	-55	-	105	°C	
Supply Voltage (Vcc)	-0.5	-	4.5	Vdc	
Control Voltage (Vc)	-1.0	-	5.0	Vdc	
Operating Supply Voltage	3.145	3.30	3.465	Vdc	

Absolute Ratings: Stresses beyond those listed under "absolute maximum ratings" may cause permanent damage to the device. These are stress ratings only. The functional operation of the device at those or any other conditions beyond those indicated under "recommended operating conditions" is not implied. Exposure to conditions outside the "recommended operating conditions" for any extended period of time may adversely impact device reliability and result in failures not covered by warranty.

Operating Specifications

Parameter	Minimum	Nominal	Maximum	Units	Notes
Center Frequency (Fo)	-	10.0 or 12.8	-	MHz	
Operating Temperature					
OH320-LA-71003CV	-20		70	°C	
OH320-LA-61003CF/CV	-40		85	°C	
Frequency Calibration @ 25°C	-100	-	100	ppb	
Frequency Stability vs. Temperature	-10	-	10	ppb	1
Frequency vs. Supply Voltage	-0.5	-	0.5	ppb	Vcc $\pm 5\%$
Frequency vs. Load	-0.5	-	0.5	ppb	Load $\pm 5\%$
Aging: Daily	-0.5	-	0.5	ppb/day	2
Aging: First Year	-50	-	50	ppb	
Lifetime Tolerance: (20 years)	-300	-	300	ppb	3
Supply Voltage (Vcc)	3.13	3.30	3.47	Vdc	4
Power Consumption: Vcc = 3.30 Vdc					
OH320-LA-71003CV Steady State @ 25°C	-	-	1.15	W	5
Turn On @ -20°C	-	-	3.20	W	5
OH320-LA-61003CF/CV Steady State @ 25°C	-	-	1.50	W	5
Turn On @ -40°C	-	-	3.63	W	5
Phase Jitter: (BW: 10 Hz to Fo/2)	-	-	1.0	ps rms	
Allan Deviation (Tau=1s)	-	2.7E-12	5.0E-12		
Start-Up Time:	-	-	500	ms	
Warm Up Time: @ 25°C	-	-	5	minutes	6

Phase Noise

Parameter	Minimum	Nominal	Maximum	Units	Notes
SSB Phase Noise at 1Hz offset	-	-	-85	dBc/Hz	
SSB Phase Noise at 10Hz offset	-	-	-115	dBc/Hz	
SSB Phase Noise at 100Hz offset	-	-	-140	dBc/Hz	
SSB Phase Noise at 1KHz offset	-	-	-145	dBc/Hz	
SSB Phase Noise at 10KHz offset	-	-	-150	dBc/Hz	
SSB Phase Noise at 100KHz offset	-	-	-150	dBc/Hz	

Voltage Control Input Characteristics (VCOCXO only)

Parameter	Minimum	Nominal	Maximum	Units	Notes
Control Voltage Range	0.0	1.65	3.3	V	7
Pull Range	± 0.4	± 0.6	-	ppm	
Input Impedance	100K	-	-	Ohm	



Attention: System Designers please review Application Note AN2093:
 System Design Information and Printed Circuit Board Layout Guidelines for OCXO Oscillators.
 @ www.conwin.com/support.html





Ordering Information

OH320-LA-71003CV-012.8M, OH320-LA-61003CV-010.0M, OH320-LA-61003CF-010.0M

CMOS Output Characteristics

Parameter	Minimum	Nominal	Maximum	Units	Notes
Load	-	15	-	pF	
Output Voltage: High (Voh)	3.0	-	-	V	
Output Voltage: Low (Vol)	-	-	0.4	V	
Output Current: High (Ioh)	-4	-	-	mA	
Output Current: Low (Iol)	-	-	4	mA	
Duty Cycle at 50% of Vcc	45	50	55	%	
Rise / Fall Time: 10% to 90%	-	-	6	ns	
Spurious Output	-	-	-80	dBc	

Notes:

1. Referenced to the frequency measured @ 25°C, VCOCXO Control Voltage (Vc) = Nominal Voltage.
2. At time of shipment after 48 hours of operation.
3. Inclusive of Calibration, Operating Temperature, Supply Voltage change, Load change, and 20 Year Aging.
4. Supply voltage must reach Vcc levels monotonically within a ramp-up time of <12 ms.
5. Measured with Vcc = Nominal in calm air.
6. Measured @ 25°C, within ±100 ppb, referenced one hour after turn-on.
7. To ensure proper operation of VCOCXO's, the control voltage input must be biased at the nominal control voltage. Failure to bias the Vc input will result in unstable operation.

Re-Stabilization Time

Off Time	Re stabilization Time
<1 Hour	<2 Hours *
<6 Hour	<12 Hours *
<24 Hour	<48 Hours *
1 to 16 Days	48 Hours + 1/4 Off Time *
>16 Days	<6 Days *

* For a given off time, the time required to meet daily aging, short term stability requirements.

Package Characteristics

OH320 Package Package consisting of a FR4 substrate and Folded Metal cover. Non-hermetic seal.

Environmental Characteristics

Shock	500 G's 1ms, Halfsine, 3 shocks per direction, per MIL-STD 202G, Method 213B Test Condition D.
Sinusoidal Vibration	0.06" D.A. or 10G's Peak, 10 to 500 Hz, per MIL-STD-202G, Method 204D, Test Condition A.
Random Vibration	5.35 G's rms. 20 to 2000 Hz per MIL-STD-202G, Method 214, Test Condition 1A, 15 minutes each axis.
Moisture	10 cycles, 95% RH, Per MIL-STD-202G, Method 112.
Marking Permanency	Per MIL-STD-202G, Method 215J.

Solder Process Recommendations: RoHS compliant, lead free. See solder profile on page 4.

In-line reflow:	Refer to recommended reflow pre-heat and reflow temperatures on page 4. Package material consists of metal cover with FR4 substrate. Component solder is Pb-free high temperature eutectic alloy with melting point of 221 deg C.
In-line oven profile:	We recommend using KIC profiler or similar device placing one of the thermocouples on the device to insure that the internal package temperature does not exceed 221°C.
Removal of device:	If for any reason the device needs to be removed from the board, use a temperature controlled repair station with profile monitoring capabilities. Following a monitored profile will insure the device is properly pre-heated prior to reflow. Refer to IPC 610E for inspection guidelines.

Recommended Cleaning Process: (If required)

Device is non-hermetic, water resistance with four weep holes, one in each corner to allow moisture to be removed during the drying cycle. We recommend in-line warm water wash with air knife and drying capabilities. If cleaner does not have drying capability, then use hot air circulated oven. Boards should be placed in the oven vertically for good water runoff

Device must be dried properly prior to use!

Note: If saponifier is used make sure the device is rinsed properly to insure all residues are removed. PH of saponifier should not exceed 10.

Drying Temperature:	Between 85 to 100°C.
Drying Time:	Time will vary depending on the board size.

Caution: Do not submerge the device!



Attention: System Designers please review Application Note AN2093:
System Design Information and Printed Circuit Board Layout Guidelines for OCXO Oscillators.
@ www.conwin.com/support.html

Bulletin	Cx302
Page	2 of 5
Revision	08
Date	20 April 2022



Package Outline

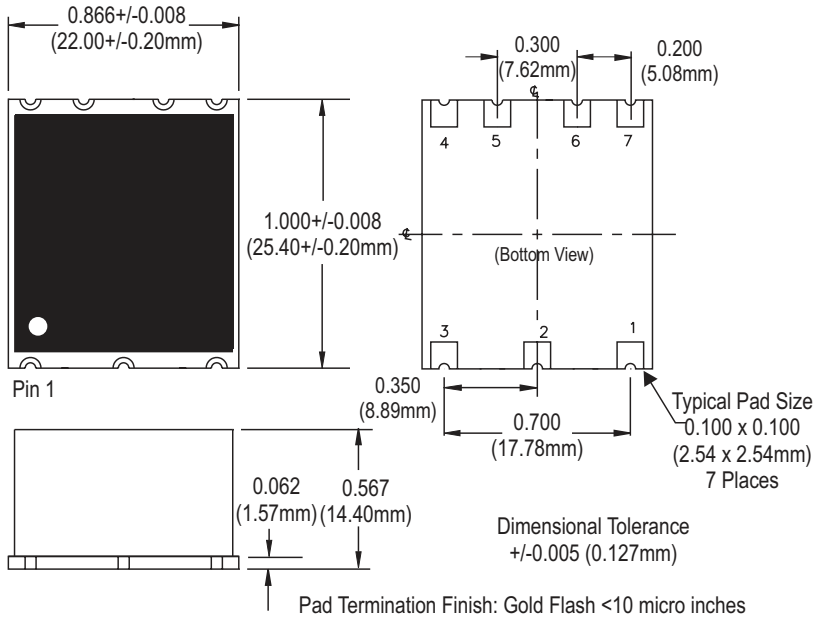

Suggested Pad Layout

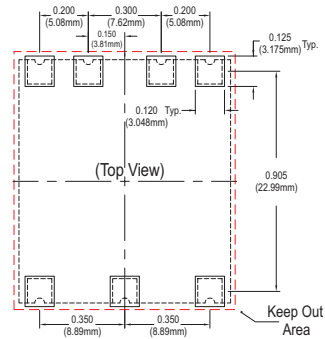

* Do not route any traces in the keep out area. It is recommended the next layer under the keep out area is to be ground plane.

Marking Information

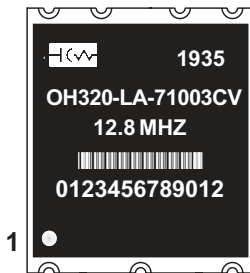

Date Code (YYWW)
Model Number
Output Frequency
Serial # Barcode
Serial Number

Pad Connections

Pad	Connection
1:	Control Voltage (VCOCXO) or N/C (OCXO)
2:	Do not Connect
3:	Supply Voltage (Vcc)
4:	RF Output
5:	Do Not Connect
6:	Do Not Connect
7:	Ground

DO NOT connect "DNC" pads to ground or supply rails.

Test Circuit

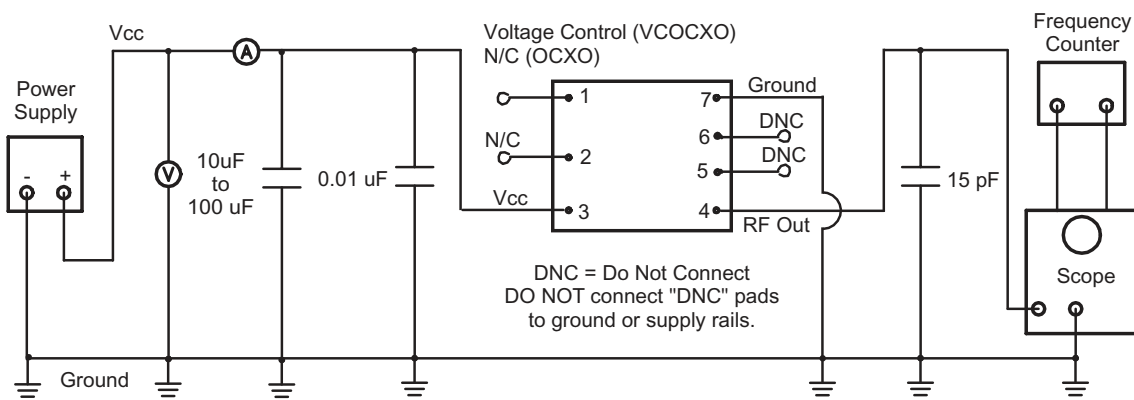

Attention: System Designers please review Application Note AN2093:
System Design Information and Printed Circuit Board Layout Guidelines for OCXO Oscillators.
www.conwin.com/support.html

Bulletin	Cx302
Page	3 of 5
Revision	08
Date	20 April 2022

MTIE per Stratium 3E (OCXO is covered) Loop Bandwidth = 0.0016 Hz

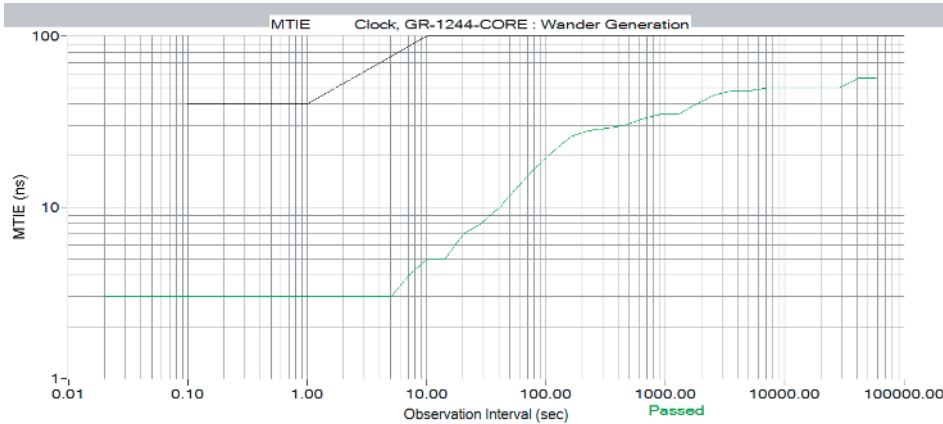

Solder Profile

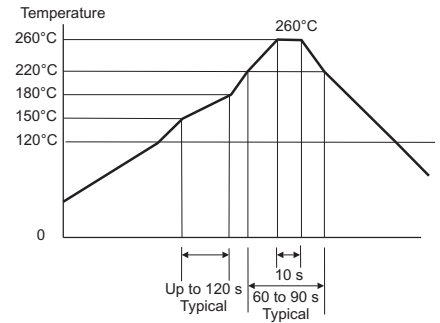

Meets IPC/JEDEC J-STD-020C

ADEV Plot

Allan Deviation $\sigma_y(\tau)$

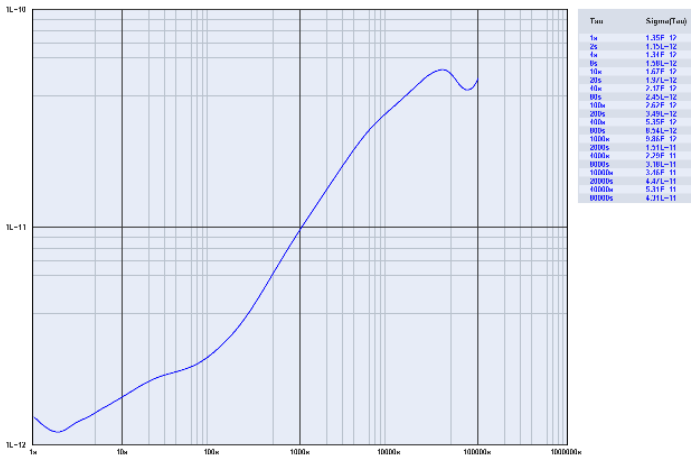

TDEV & MTIE 4-Day Stability Measurement Through HPF (1MHz)

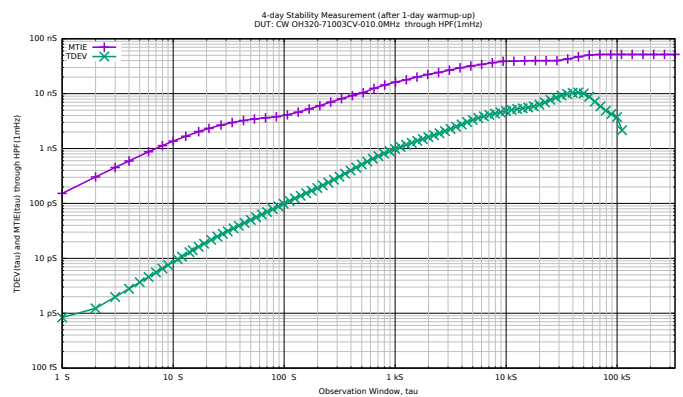

Orderable Part Numbers:

OH320-LA-71003CV-012.8M

OH320-LA-61003CV-010.0M

OH320-LA-61003CF-010.0M

Tape and Reel Information

MEETS EIA-481A AND EIAJ-1009B
100 PCS/REEL MAXIMUM

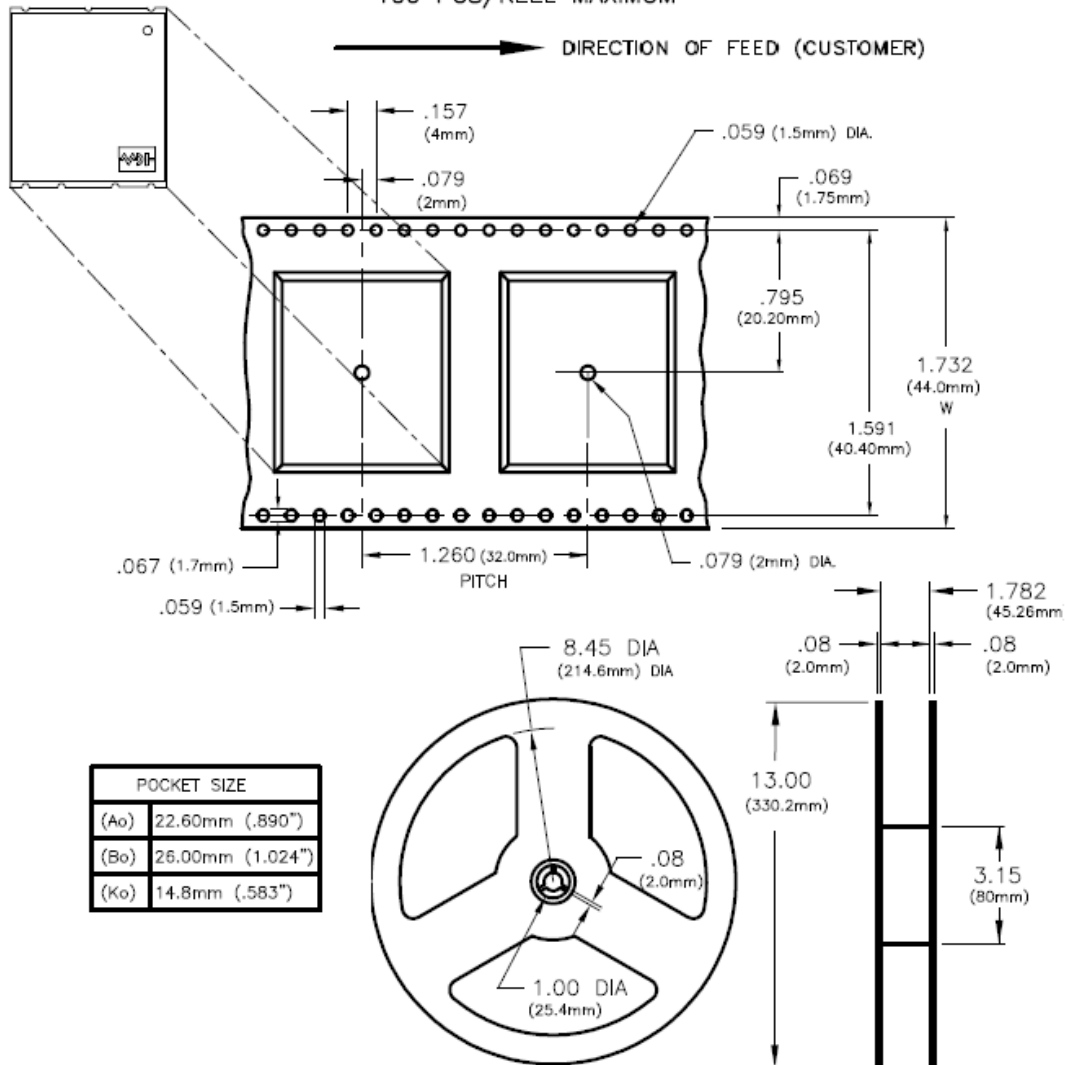

Revision History

Revision	Date	Changes
00	05/17/19	Initial Release
01	05/23/19	Updated Output & Center Frequencies,
02	07/16/19	Updated Package Height Dimensions
03	07/31/19	P/N change to add LA (low ADEV) designation and updated Pin 1 description in test circuit
04	08/07/19	Updated package height and tape dimensions.
05	09/17/19	Removed T&R Dimensions
06	10/07/20	Added p/n OH320-LA-61003CF and updated for sale at DigiKey
07	12/15/20	Added Tape & Reel Information
08	04/20/22	Added p/n OH320-LA-61003V

Bulletin	Cx302
Page	5 of 5
Revision	08
Date	20 April 2022