

High Efficiency Off-Line CC/CV Switch

FEATURES

- Constant-Current (CC) and Constant-Voltage (CV) with Primary Side Control
- Proprietary technology enabling high efficiency and fast dynamic response
- No audible noise over entire operating range
- Built-in power MOS
- Built-in Cable Compensation
- Built-in Line Compensation
- Primary-side feedback eliminates opto-coupler and TL431
- Cycle-by-Cycle Current Limiting
- Over Temperature Protection
- VCC Over Voltage Protection
- CV Open-loop Protection
- Excellent capacitive loading start-up performance

TYPICAL APPLICATION

- Adapter/Charger for Cell/Cordless Phones, PDAs, MP3 and Other Portable Apparatus
- Standby and Auxiliary Power Supplies Set Top Boxes (STB)
- Adapter for ADSL / WiFi Wireless
- AC/DC LED Driver applications

DESCRIPTION

The FT838MBD/FT838MDD controller device is optimized for high-performance, low power switching mode power supply applications. The FT838MBD/FT838MDD facilitates CC/CV charger design by eliminating an opto-coupler and TL431. Its highly integrated functions such as Under Voltage Lockout (UVLO), Leading Edge Blanking (LEB) and built-in cable compensation offer the users a high efficiency and low cost solution for AC/DC power applications.

Power supplies built with FT838MBD/FT838MDD can achieve both high average efficiency, fast dynamic load response and super low standby power.

Furthermore, FT838MBD/FT838MDD features fruitful protections like Open Circuit Protection and Over Temperature Protection to eliminate the external protection circuits and provide reliable operations. FT838MBD/FT838MDD is available in DIP8 package.

TYPICAL APPLICATION CIRCUIT

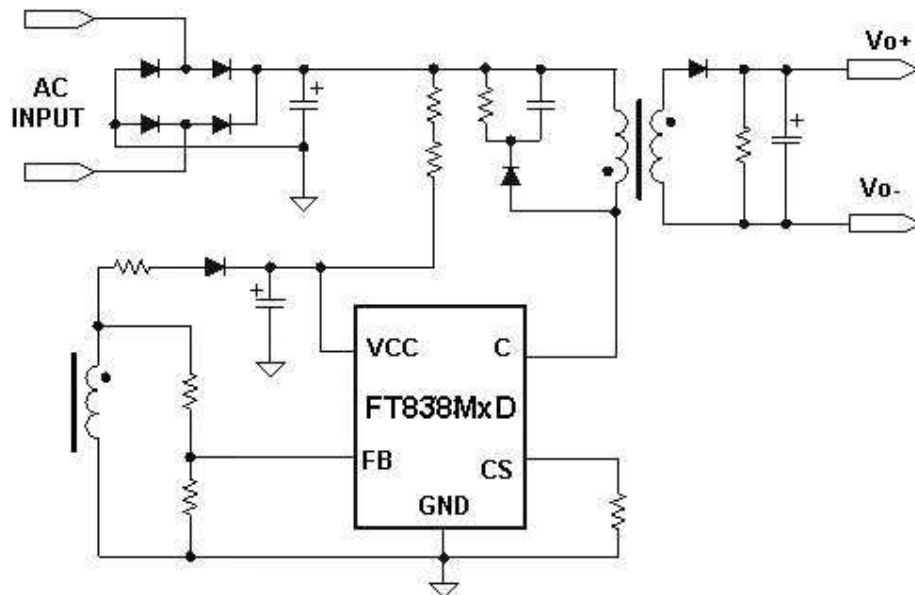

Figure 1: FT838MBD/838MDD Typical Application Circuit

ABSOLUTE MAXIMUM RATINGS

FB to GND.....	-0.3V to +7V
CS to GND.....	-0.3V to +7V
VCC to GND.....	-0.3V to +30V
C to GND.....	-0.3V to +700V
Operating Temperature Range.....	-40°C to +125°C
Junction Temperature.....	-40°C to +150°C
Storage Temperature Range	-60°C to +150°C
ESD Protection HBM.....	2000V
ESD Protection MM.....	200V

***Stresses exceeding Maximum Ratings may damage the device. Maximum Ratings are stress ratings only. Functional operation above the Recommended Operating Conditions is not implied. Extended exposure to stresses above the Recommended Operating Conditions may affect device reliability.**

PIN CONFIGURATION

Figure 2: Pin Assignments

TERMINAL DEFINITION

Pin	Name	Description
1	CS	Primary current sense
2	FB	Output voltage feedback pin
3	GND	Ground.
4	VCC	Supply voltage
5	NC	No connection
6		
7	D	The drain of the power MOS. This pin is connected to the primary lead of the transformer
8		

Table 1

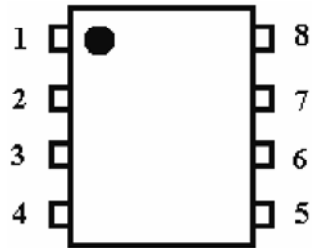
ORDERING INFORMATION

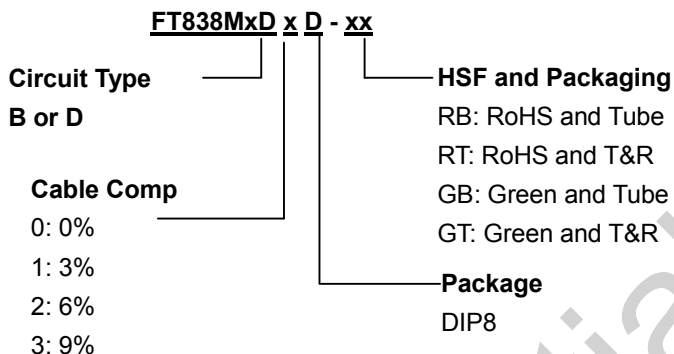

FT838MBD^①/FT838MDD^①

Device	DESIGNATOR	SYMBOL	Options
FT838MBD ^① FT838MDD ^①	①	0	Cable Comp = 0%
		1	Cable Comp = 3%
		2	Cable Comp = 6%
		3	Cable Comp = 9%

Table 2

MARKING RULE

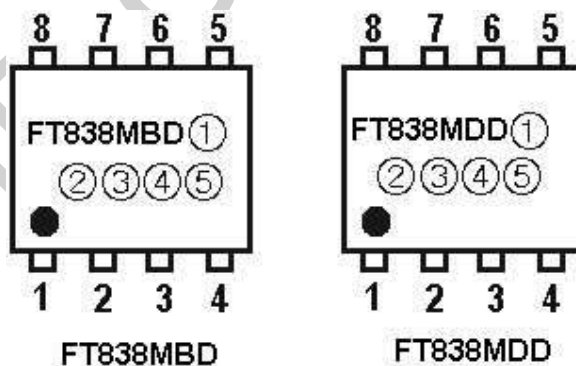

Figure 3: Marking Rule

- ①: Represents Version (0, 1, 2 or 3)
- ②③④⑤: for internal reference

Block Diagram

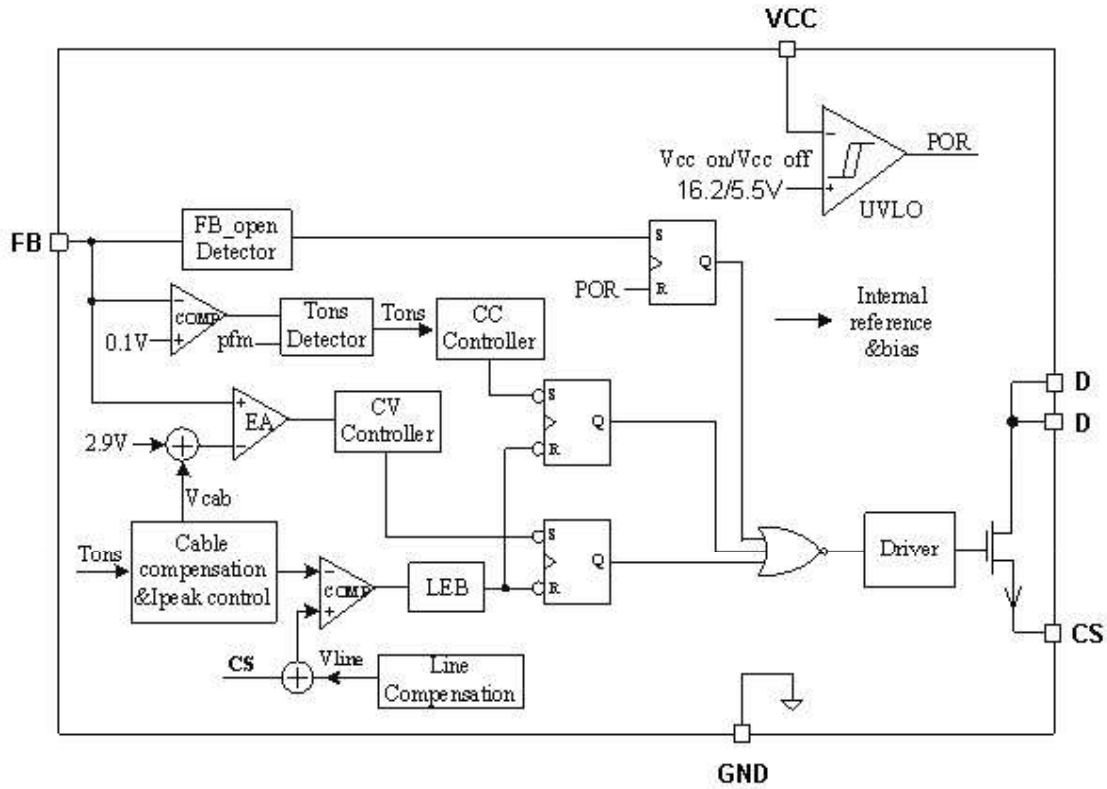

Figure 4: FT838MBD/838MDD Block Diagram

ELECTRICAL CHARACTERISTICS

(For typical values Tj=25°C, Vcc=12V, unless otherwise noted)

Characteristic		Symbol	Min	Typ	Max	Unit
Current Sense						
Maximum Current Threshold		Vcs_max	535	552	575	mV
Leading Edge Blanking Duration		Tleb	350	400	450	ns
Propagation Delay (OUT=1.0nF to GND)		Tpd			200	ns
Feedback Section						
Feedback Voltage Threshold		Vfb	2.856	2.9	2.944	V
CCM protection Threshold Level		Vcp		100		mV
Supply Section						
Start Up Threshold Voltage		Vcc_on	15.5	16.2	17.5	V
Under Voltage Lockout Voltage		Vcc_off	5.2	5.5	6.0	V
VCC Start Up Current		Istart_up		2	5	uA
Operating Current		Iop	0.4	0.5	0.7	mA
Protection Section						
Feedback Loop Open Protection		Ifb_open	90	115	140	uA
VCC Over Voltage Protection		Vcc_OVP	26	27	28	V
Over Temperature Protection		T_OTP		145		°C
Compensation						
Line Compensation (I _{fb} =1mA)		Vline	25	33	40	mV
Cable compensation	0	Kcab		0		%
	1			3		
	2			6		
	3			9		
Power MOS Section (FT838MBD)						
Characteristic	Symbol	Test condition	Min	Typ	Max	Unit
Static drain-source on-resistance	R _{DS_ON}	V _{GS} =10V, I _{DS} =0.5A		5.5		Ω
Drain-source breakdown voltage	BV _{DSS}	V _{GS} =0V, I _{DS} =250uA	650			V
Drain-source leakage current	I _{DSS}	V _{GS} =0V, V _{DS} =650V			10	uA
Maximum Drain Current	I _{DMAX}	V _d =4V	0.6	0.7		A
Power MOS Section (FT838MDD)						
Static drain-source on-resistance	R _{DS_ON}	V _{GS} =10V, I _{DS} =0.5A		2.6		Ω
Drain-source	BV _{DSS}	V _{GS} =0V,	650			V



breakdown voltage		$I_{DS}=250\mu A$				
Drain-source leakage current	I_{DSS}	$V_{GS}=0V,$ $V_{DS}=650V$			10	μA
Maximum Drain Current	I_{DMAX}	$V_d=3V$	1.0	1.1		A

Table 3

FMD Confidential

FUNCTIONAL DESCRIPTION**Operating Description**

FT838MBD/FT838MDD is a cost effective and high-performance AC-DC power supply controller for off-line low power AC-DC applications including battery chargers, adaptors and LED lighting. The constant voltage (CV) and constant current (CC) control are achieved accurately without the secondary feedback circuit.

Start up Control

Start-up current of FT838MBD/838MDD is very low so that a start-up resistor with high resistance and low-wattage is allowed to supply the start-up power for the controller. The large value startup resistor minimizes the power loss in operations and allows quick start up. With a special fast startup technology, FT838MBD/FT838MDD starts up easily in capacitive loading applications.

Operating current

The operating current of FT838MBD/FT838MDD is as low as 500uA. Good efficiency is achieved with the low operating current. Low operating current also reduces the Vcc hold-up capacitance requirement.

Constant voltage (CV) and constant current (CC) Operation

The FT838MBD/FT838MDD can accurately achieve CV/CC characteristic output without secondary side voltage and current-feedback circuits. It operates in CV mode to regulate the output voltage by capturing the auxiliary winding feedback voltage at FB pin. The auxiliary winding feedback voltage is proportional to secondary winding, so it provides controller the feedback signal from secondary side and achieves constant-voltage output. In CC mode, the controller detects the secondary discharger peak current and the discharger time, which determines the off-time of the base driver to make the output average current constant.

Primary peak current modulation

Primary peak current is constant at constant current mode. And primary peak current is modulated at constant voltage mode for the purposes of good dynamic load response and no audible noise over entire operating range. According to the output loading current the current threshold voltage is modulated from 0.55V to 0.27V. The current threshold voltage is 0.55V at rated load and 0.27V at light load.

Leading edge blanking

Each time the power MOS transistor is switched on, a turn-on spike occurs at the sense resistor. To avoid premature termination of the switching pulse, a 400ns leading edge blanking time is built in. Conventional RC filtering can therefore be omitted. During this blanking period, the current limit comparator is disabling and cannot switch off the base driver.

Under voltage lockout (UVLO)

FT838MBD/FT838MDD turn-on Vcc_on and turn-off Vcc_off are 16.2 V and 5.5 V, respectively. During start-up, the hold-up capacitor must be charged to 16.2V through the start-up resistor. The hold-up

capacitor continues to supply V_{cc} until power can be delivered from the auxiliary winding of the transformer. V_{cc} must not drop below 5.5 V during this start-up process. This UVLO hysteresis window ensures that hold-up capacitor is sufficient to supply V_{cc} during start-up.

Protection control

With rich protection features of FT838MBD/FT838MDD, excellent power supply system reliability can be achieved. The protection features include cycle by cycle current limiting, V_{cc} over voltage protection and clamp, over temperature protection, feedback loop open circuit protection and V_{cc} under voltage lockout, etc.

Integrated MOS

Power MOS is integrated in FT838MBD/FT838MDD for low cost and/or space limited applications, respectively.

Output cable compensation

The output cable compensation provides a constant output voltage at the end of the cable over the entire load range in constant voltage mode. As the converter load increases from no-load to the peak current load, the voltage drop introduced across the output cable is compensated by increasing the feedback pin reference voltage.

PACKAGE INFORMATION

DIP8 Package

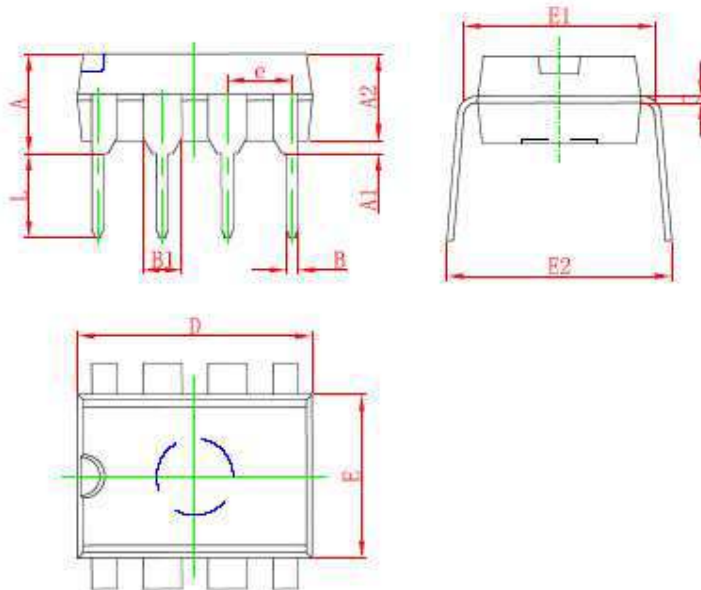

Symbol	Dimensions In Millimeters		Dimensions In Inches	
	Min	Max	Min	Max
A	3.710	4.310	0.146	0.170
A1	0.510		0.020	
A2	3.200	3.600	0.126	0.142
B	0.380	0.570	0.015	0.022
B1	1.524 (BSC)		0.060 (BSC)	
C	0.204	0.360	0.008	0.014
D	9.000	9.400	0.354	0.370
E	6.200	6.600	0.244	0.260
E1	7.320	7.920	0.288	0.312
e	2.540 (BSC)		0.100 (BSC)	
L	3.000	3.600	0.118	0.142
E2	8.400	9.000	0.331	0.354



Fremont Micro Devices (SZ) Limited

#5-8, 10/F, Changhong Building, Ke-Ji Nan 12 Road, Nanshan District, Shenzhen, Guangdong 518057
Tel: (86 755) 86117811
Fax: (86 755) 86117810

Fremont Micro Devices (Hong Kong) Limited

#16, 16/F, Blk B, Veristrong Industrial Centre, 34-36 Au Pui Wan Street, Fotan, Shatin, Hong Kong
Tel: (852) 27811186
Fax: (852) 27811144

Fremont Micro Devices (USA), Inc.

42982 Osgood Road Fremont, CA 94539
Tel: (1-510) 668-1321
Fax: (1-510) 226-9918

Web Site: <http://www.fremontmicro.com/>

* Information furnished is believed to be accurate and reliable. However, Fremont Micro Devices, Incorporated (BVI) assumes no responsibility for the consequences of use of such information or for any infringement of patents of other rights of third parties which may result from its use. No license is granted by implication or otherwise under any patent rights of Fremont Micro Devices, Incorporated (BVI). Specifications mentioned in this publication are subject to change without notice. This publication supersedes and replaces all information previously supplied. Fremont Micro Devices, Incorporated (BVI) products are not authorized for use as critical components in life support devices or systems without express written approval of Fremont Micro Devices, Incorporated (BVI). The FMD logo is a registered trademark of Fremont Micro Devices, Incorporated (BVI). All other names are the property of their respective owners.