

REVISIONS				
P	LTN	DESCRIPTION	DATE	APVD
A		NEW DRAWING	02APR2019	RS JO

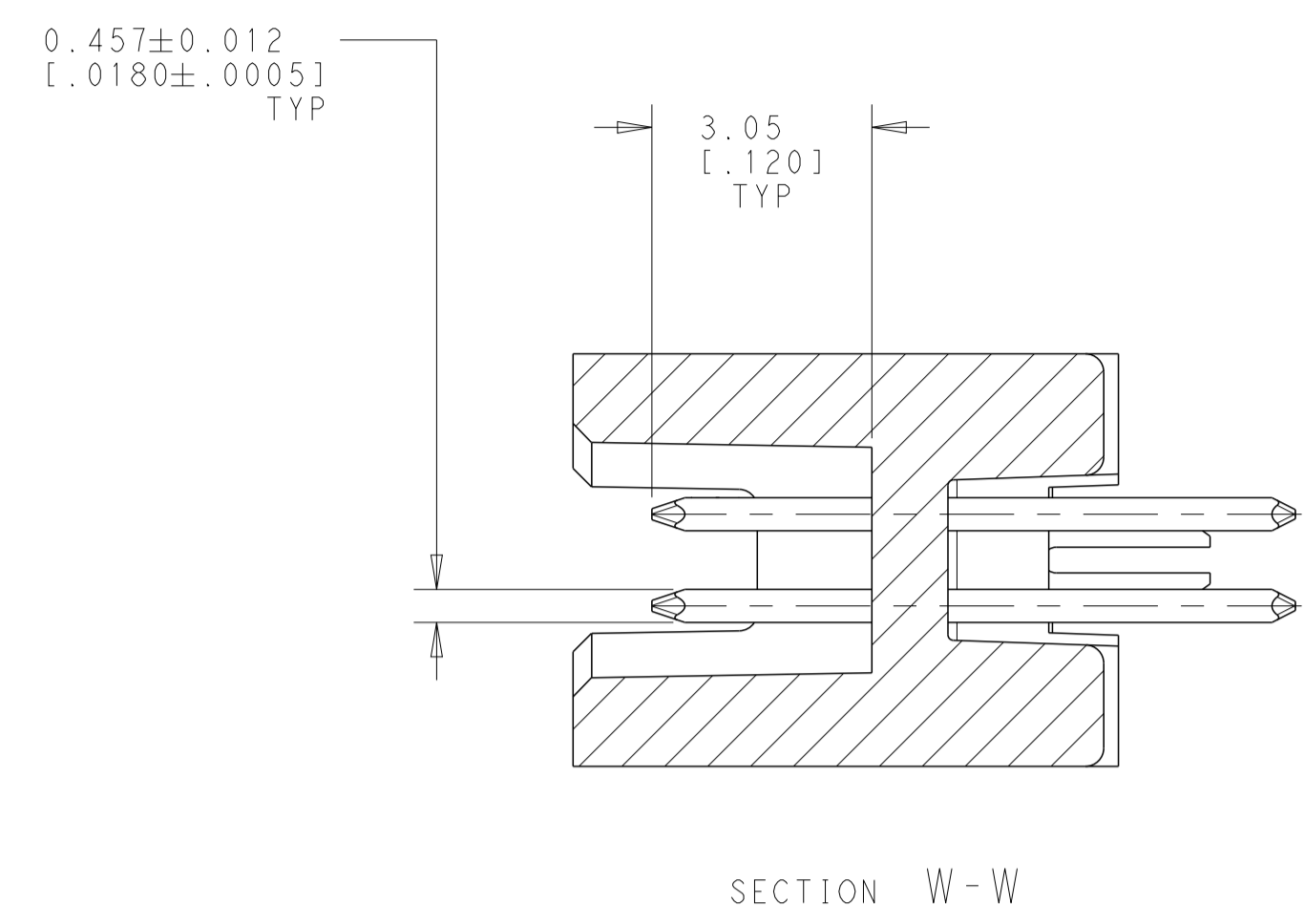

- 1 0.00076[.000030] GOLD AT POINT OF MEASUREMENT 0.0005[.000020] MIN AT THE END POINTS OF AREA G. (LOCALIZED GOLD PLATE AREA), 0.0038[.000150] TIN-LEAD ON LOCALIZED TIN PLATED AREA, ALL OVER 0.0013[.000050] NICKEL
- 2 USE 1.32±.002[.052±.001] DRILLED HOLE (#55 DRILL). FINISH TO BE TIN OVER 0.02[.001]MIN COPPER.
- 3 DIMENSION APPLIES AT BASE OF SHROUD
- 4 THE NOTED DIMENSIONS APPLY AT THE MATING FACE OF THE HOUSING.
- 5 0.0038[.000150] TIN LEAD ON HOLD DOWN, ALL OVER 0.0013[.000050] NICKEL
- 6 IF PLANNING TO USE MORE THAN ONE MATING PAIR OF CONNECTORS TO INTERCONNECT 2 BOARDS, PLEASE REFER TO THE SPACING PARAGRAPH IN APPLICATION SPEC, #114-7010
- 7 DIMENSION NOTED APPLY FROM THE BASIC DIMENSION LINE (NOT THE CIRCUIT CAVITY CENTRE LINE) TO THE SURFACE INDICATED.
- 8 PACKAGED IN TAPE AND REEL PER EIA-481 SPECIFICATIONS, SEE CHART FOR TAPE WIDTHS.
- 9 HOUSING: LCP, COLOR: BLACK
POST: PHOSPHUR BRONZE
HOLD DOWN: COPPER ALLOY
VACCUM COVER: ALUMINIUM
- 10 0.00076[.000030] GOLD AT POINT OF MEASUREMENT 0.0005[.000020] MIN AT THE END POINTS OF AREA G. (LOCALIZED GOLD PLATE AREA), 0.0038[.000150] TIN ON LOCALIZED TIN PLATED AREA, ALL OVER 0.0013[.000050] NICKEL
- 11 USE 1.55+/- .02(.0610+/- .0010) DRILLED HOLE FINISH TO BE TIN OVER 0.029.0010MIN COPPER.
- 12 0.0038[.000150] TIN ON HOLDDOWN, ALL OVER 0.0013[.000050] NICKEL

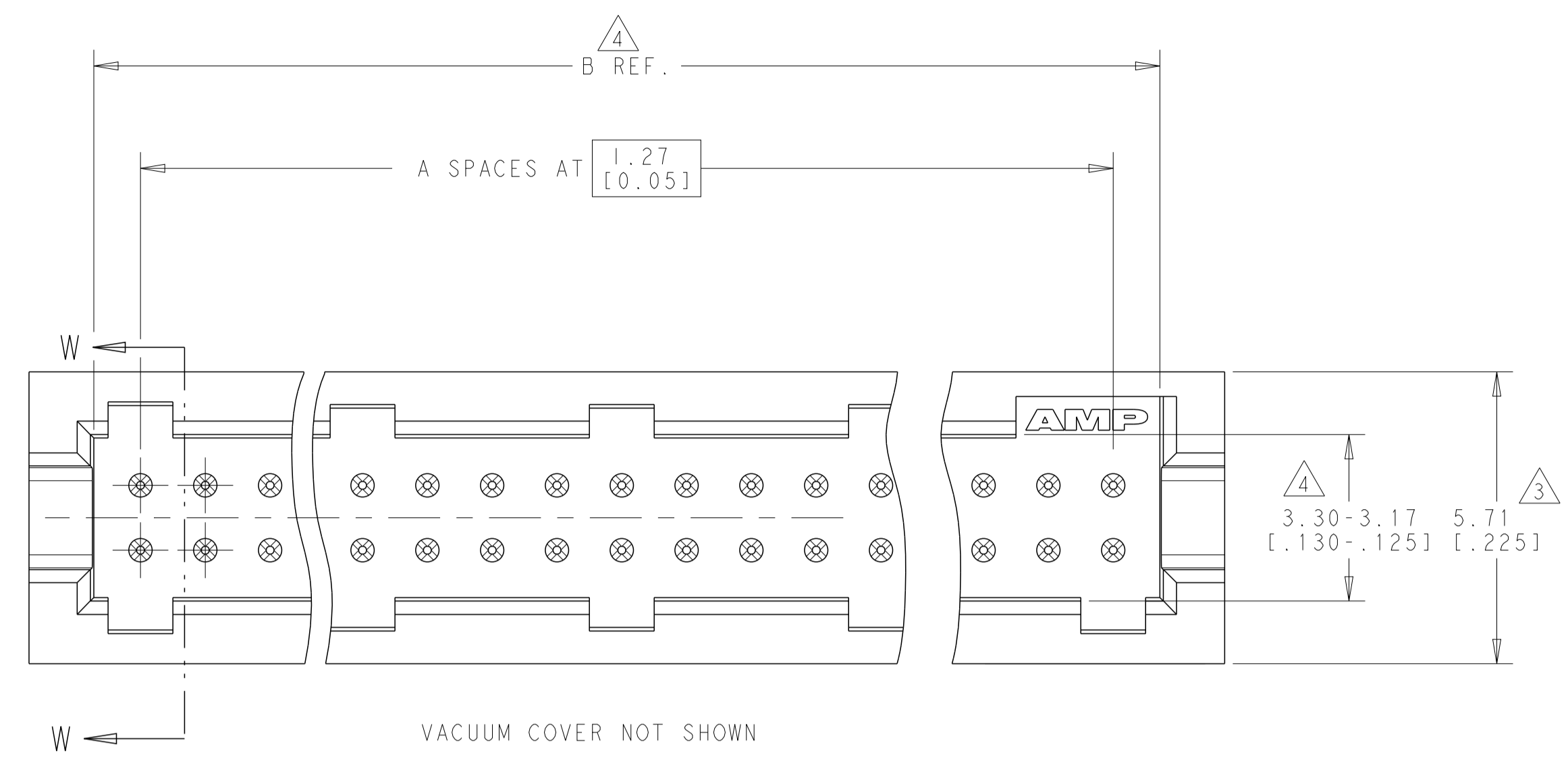
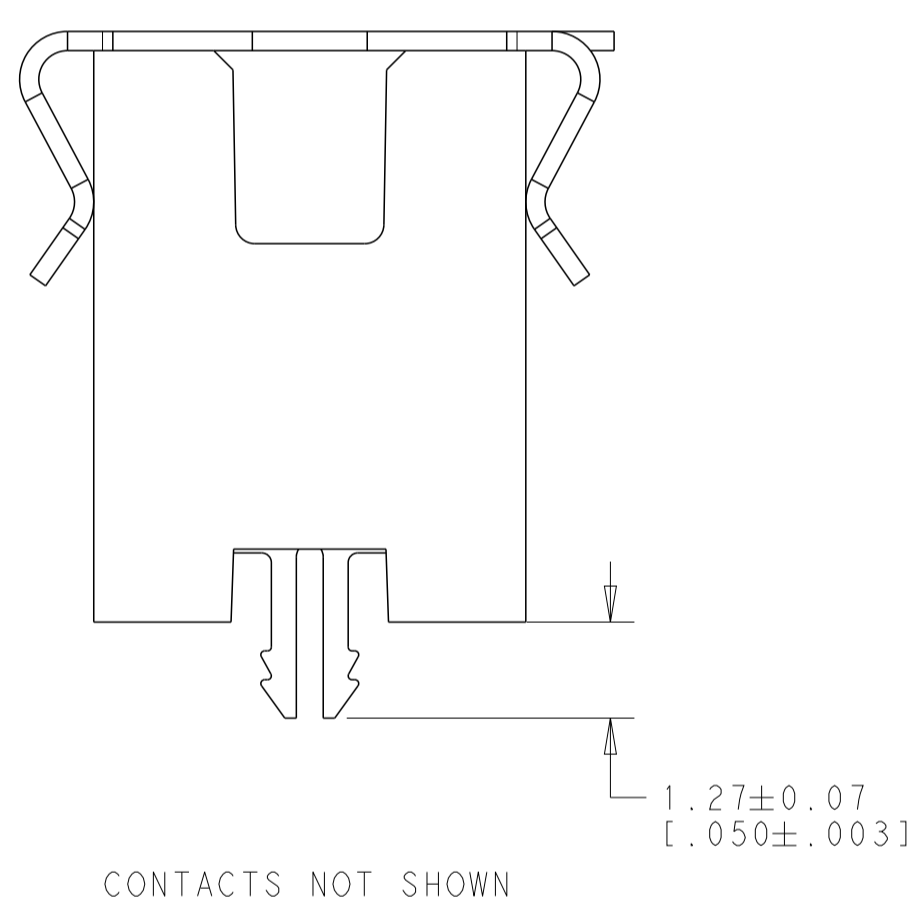
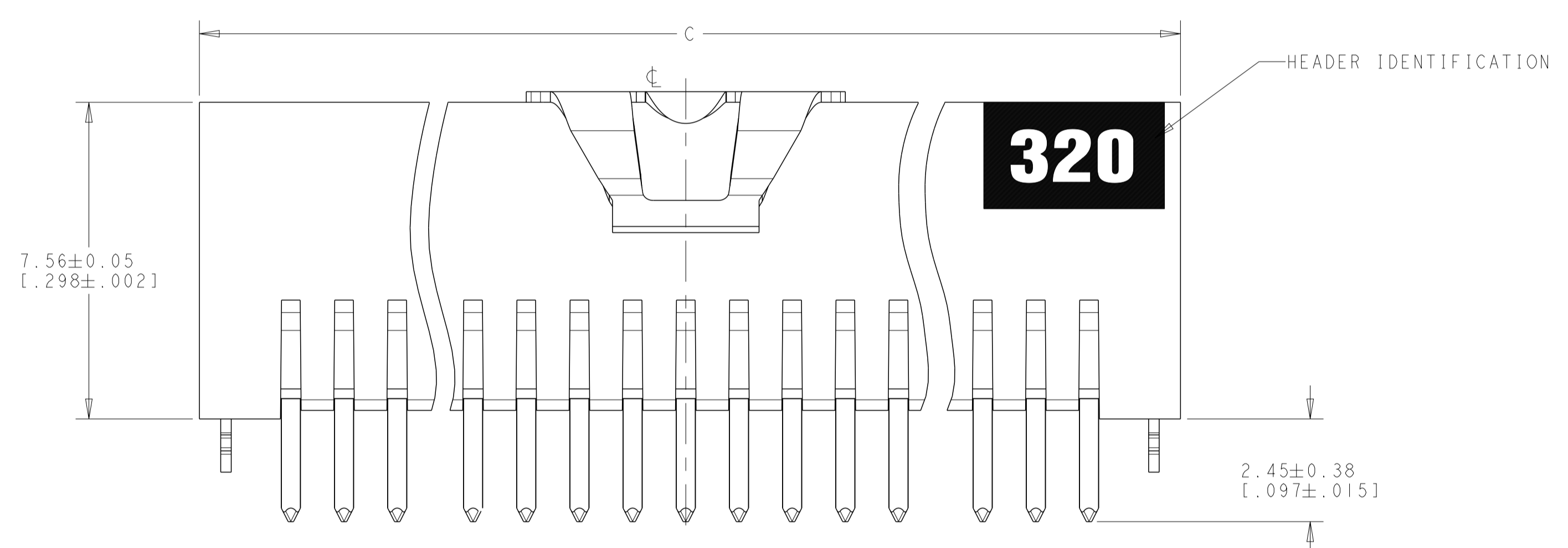

FINISH	TAPE WIDTH	D	C	B	A	NUMBER OF POSITIONS	PART NUMBER
1,2	88mm	65.33 [2.572]	66.59 [2.622]	64.05 [2.522]	49	100	6-2267259-0
1,2	88mm	58.98 [2.322]	60.25 [2.372]	57.71 [2.272]	44	90	5-2267259-9
1,2	72mm	52.63 [2.072]	53.89 [2.122]	51.35 [2.022]	39	80	5-2267259-8
1,2	72mm	46.28 [1.822]	47.54 [1.872]	45.00 [1.772]	34	70	5-2267259-7
1,2	56mm	39.93 [1.572]	41.19 [1.622]	38.65 [1.522]	29	60	5-2267259-6
1,2	56mm	33.58 [1.322]	34.84 [1.372]	32.30 [1.272]	24	50	5-2267259-5
1,2	44mm	27.23 [1.072]	28.49 [1.122]	25.95 [1.022]	19	40	5-2267259-4
1,2	32mm	20.88 [1.822]	22.14 [1.872]	19.60 [1.772]	14	30	5-2267259-3
1,2	32mm	14.53 [1.572]	15.79 [1.622]	13.25 [1.522]	9	20	5-2267259-2
1,2	24mm	8.18 [0.322]	9.44 [1.372]	6.90 [1.272]	4	10	5-2267259-1
1,5	88mm	65.33 [2.572]	66.59 [2.622]	64.05 [2.522]	49	100	1-2267259-0
1,5	88mm	58.98 [2.322]	60.25 [2.372]	57.71 [2.272]	44	90	2267259-9
1,5	72mm	52.63 [2.072]	53.89 [2.122]	51.35 [2.022]	39	80	2267259-8
1,5	72mm	46.28 [1.822]	47.54 [1.872]	45.00 [1.772]	34	70	2267259-7
1,5	56mm	39.93 [1.572]	41.19 [1.622]	38.65 [1.522]	29	60	2267259-6
1,5	56mm	33.58 [1.322]	34.84 [1.372]	32.30 [1.272]	24	50	2267259-5
1,5	44mm	27.23 [1.072]	28.49 [1.122]	25.95 [1.022]	19	40	2267259-4
1,5	32mm	20.88 [1.822]	22.14 [1.872]	19.60 [1.772]	14	30	2267259-3
1,5	32mm	14.53 [1.572]	15.79 [1.622]	13.25 [1.522]	9	20	2267259-2
1,5	24mm	8.18 [0.322]	9.44 [1.372]	6.90 [1.272]	4	10	2267259-1

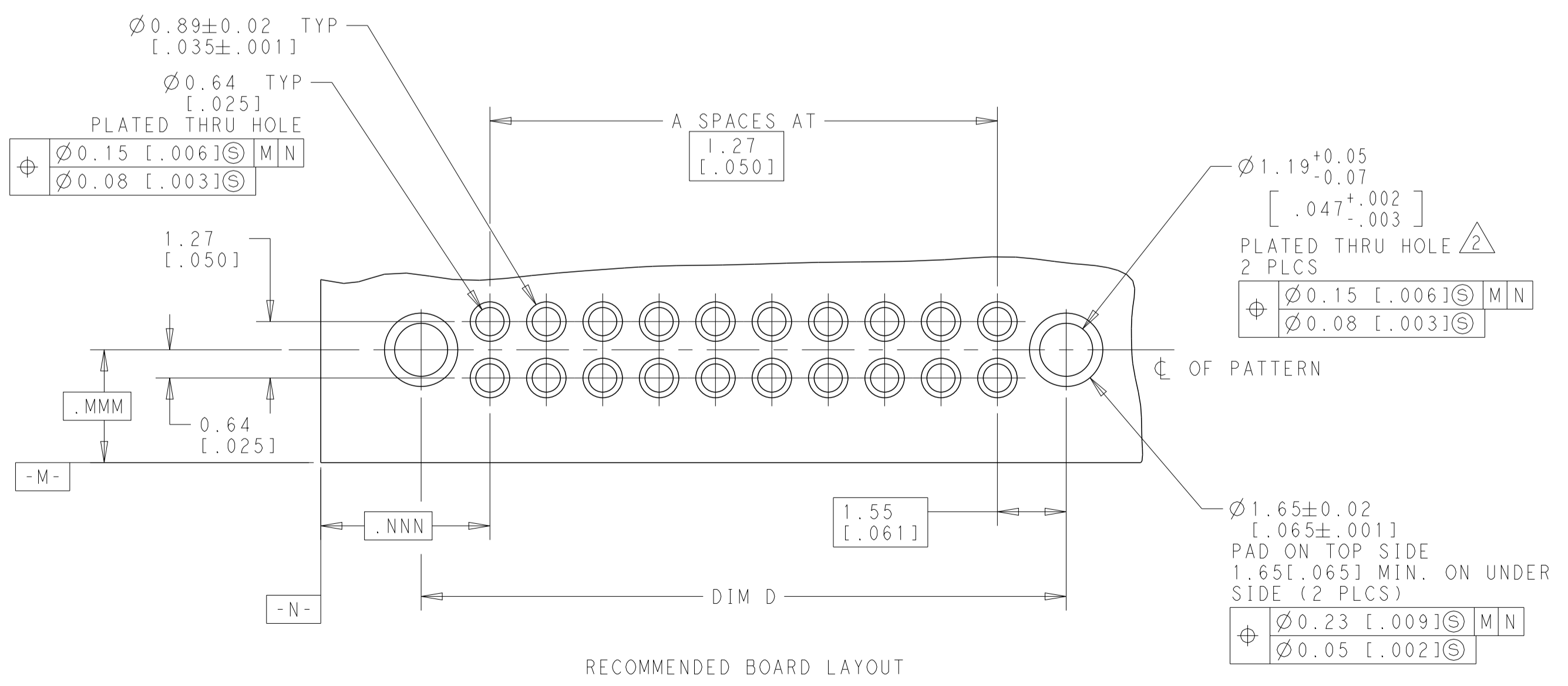

THIS DRAWING IS A CONTROLLED DOCUMENT. DIMENSIONS: mm [INCH]. TOLERANCES UNLESS OTHERWISE SPECIFIED: 0 PLC ±, 1 PLC ±, 2 PLC ±, 3 PLC ±, 4 PLC ±, ANGLES ±. MATERIAL: 9. FINISH: SEE TABLE. CUSTOMER DRAWING. SCALE: 5:1. SHEET 1 OF 1. REV A.

DATE: 01APR2019. NAME: HEADER ASSY, THROUGH HOLE AMPMODU 50/50 GRID (8.12[.320] MATED HEIGHT). SIZE: 114-7010. WEIGHT: -. RESTRICTED TO: A100779C=2267259.