

**1508-0009 CARRIER**  
**ACTUAL SIZE IN CHAIN FORM**  
 SEE NOTE 3

NOTES:

1. MATERIAL:  
BRASS, ALLOY #C26000 .012±.0002 (0.305±0.013) THICK.
2. PLATING:  
PRETINNED, HOT TIN DIP ON STRIP,  
.000020/(0.00051) MIN.
3. TERMINAL MATES WITH .020/(0.51) X .125/(3.18)  
MALE SPADE.
4. FOR CRIMPING TO THE FOLLOWING WIRES:  
SINGLE 14, 16 OR 18 AWG OR DOUBLE 18 OR 20 AWG  
WITH .031/ (0.79) THICK INSULATION.
5. 1508-0009 CARRIER TYPE TERMINALS WOUND  
ON 24 INCH REELS.

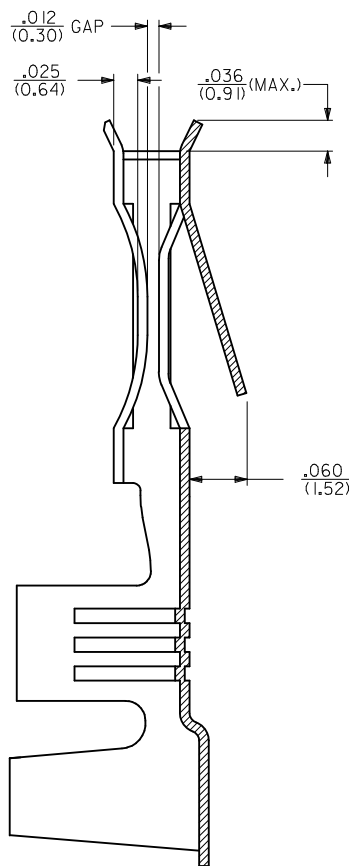
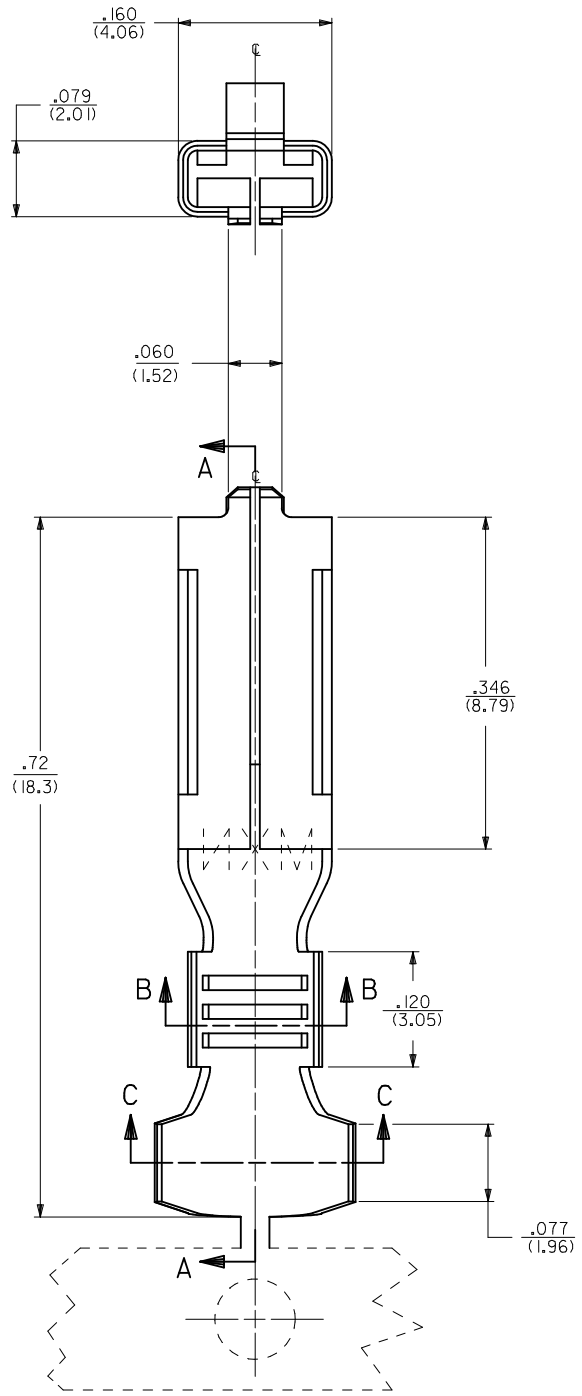

**SECTION A-A**

B	REVISED NOTES PER UCP2010-0217 09-07-23 CLS
A	REMOVE "X" PER EGM# U40224 94/02/16 MAB

MFG.	SH.	REV.	LTR.	REVISIONS



DIMENSIONS SHOWN (METRIC) INCH	
UNLESS OTHERWISE SPECIFIED TOLERANCES: ANGULAR ± 1/2°	
INCH	METRIC
3 PLACE ± .010	---
2 PLACE ± .014	± 0.25
1 PLACE ---	± 0.35
DRAFT WHERE APPLICABLE MUST REMAIN WITHIN DIMENSIONS	
DRWG. BY: MAB	CHK'D. BY: KBP
APP'D. BY: RAS	SCALE: 10: 1

▽ = 0	▼ = 0	REVISE ONLY ON CAD SYSTEM	
TITLE: TERMINAL, OPEN END FOR .020/(0.51) X .125/(3.18) SPADE, CRIMP			
MOLEX INCORPORATED		SHEET NO. 1 OF 2	DATE 94/02/16
PART NO. SD-1508-0009		DRWG. NO. U.S.A.	
SEE SHEET 2		SD-1508-0009	
THIS DRAWING CONTAINS INFORMATION THAT IS PROPRIETARY TO MOLEX INC. AND SHOULD NOT BE USED WITHOUT WRITTEN PERMISSION.			

13 12 11 10 9 8 7 6 1508 4 3 2 1

PART NO.	ENG. NO.	FORM
005-06-0117	1508-0009	CHAIN
005-06-0118	1508-1009	LOOSE

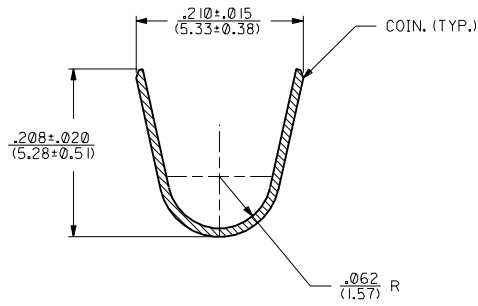

SECTION C-C

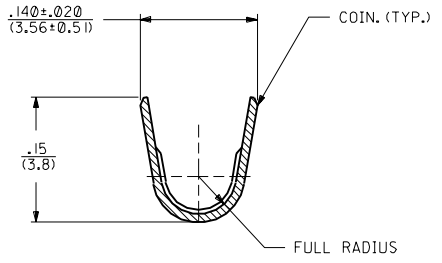

SECTION B-B

A	SEE SHEET 1
---	-------------

DIMENSIONS SHOWN METRIC (INCH)		▽ = 0	▼ = 0	REVISE ONLY ON CAD SYSTEM													
UNLESS OTHERWISE SPECIFIED TOLERANCES: ANGULAR ± 1/2°		TITLE															
<table border="1"> <thead> <tr> <th></th> <th>INCH</th> <th>METRIC</th> </tr> </thead> <tbody> <tr> <td>3 PLACE</td> <td>± .010</td> <td>---</td> </tr> <tr> <td>2 PLACE</td> <td>± .014</td> <td>± 0.25</td> </tr> <tr> <td>1 PLACE</td> <td>---</td> <td>± 0.35</td> </tr> </tbody> </table>			INCH	METRIC	3 PLACE	± .010	---	2 PLACE	± .014	± 0.25	1 PLACE	---	± 0.35	TERMINAL, OPEN END FOR .020/(0.51) X .125/(3.18) SPADE CRIMP			
	INCH	METRIC															
3 PLACE	± .010	---															
2 PLACE	± .014	± 0.25															
1 PLACE	---	± 0.35															
DRAFT WHERE APPLICABLE MUST REMAIN WITHIN DIMENSIONS		PART NO. <b>SEE CHART</b> FILE NAME SD1508X10.DWG		DRWG. NO. <b>SD-1508-0009</b> DIV. CP													
DRWG. BY: MAB	CHK'D. BY: KBP	SCALE: 10:1		THIS DRAWING CONTAINS INFORMATION THAT IS PROPRIETARY TO MOLEX INC. AND SHOULD NOT BE USED WITHOUT WRITTEN PERMISSION.													

13 12 11 10 9 8 7 6 5 4 3 2 1