

THIS DRAWING IS UNPUBLISHED. RELEASED FOR PUBLICATION  
 © COPYRIGHT BY TYCO ELECTRONICS CORPORATION. ALL RIGHTS RESERVED.

DESIGNED FOR USE WITH RG-188A/U FLEX CABLE CABLE ENTRY DIAMETER MINIMUM	
FERRULE	.125
CONTACT	.025
HOUSING	.066

LOC	DIST	REVISIONS					
AJ	00	P	LTR	DESCRIPTION	DATE	DWN	APVD
		B		REV PER ECO 07-004710	3/9/2007	DW	KW

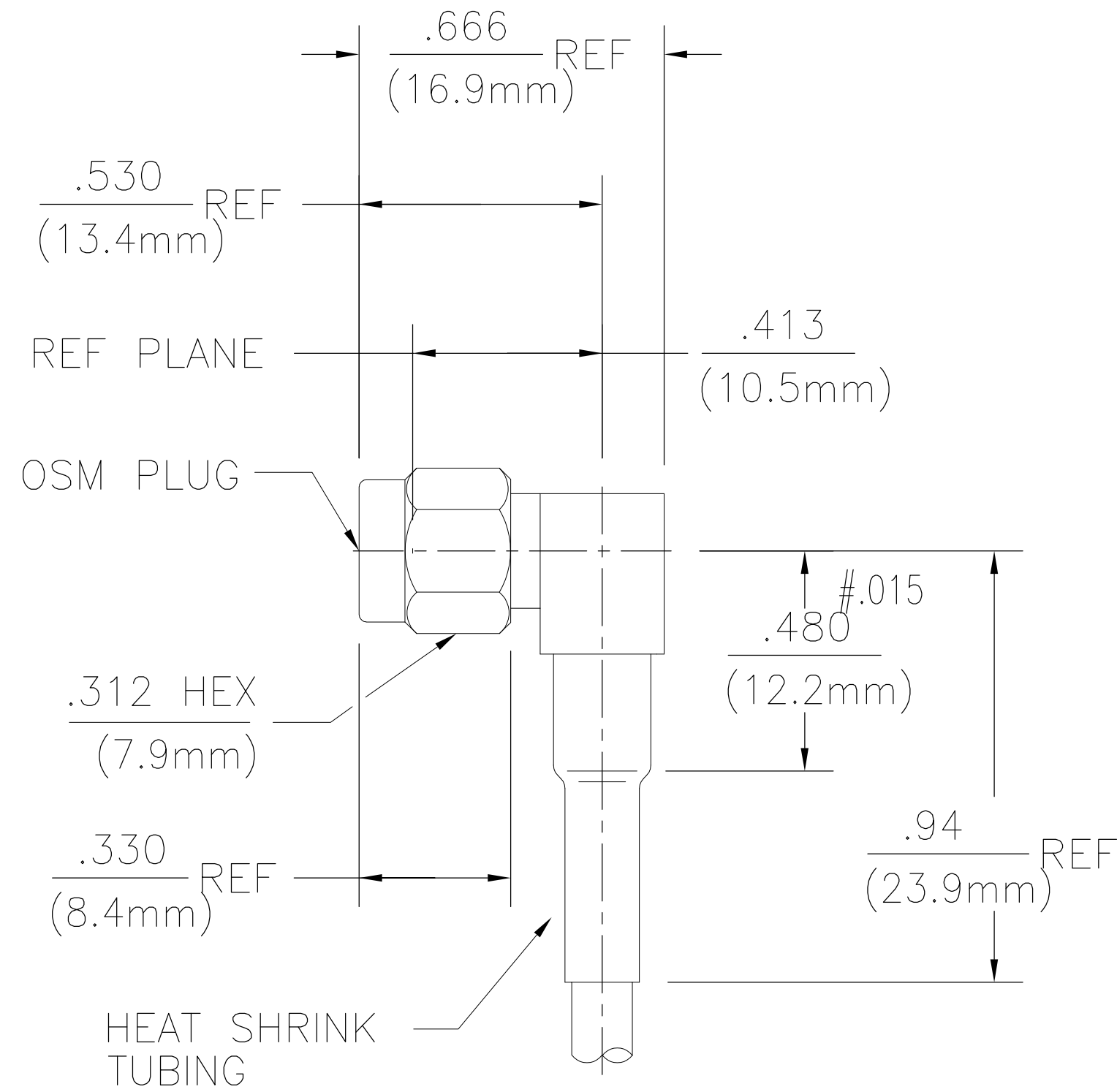

1052076-1  
PART NUMBER

HOUSING COUPLING NUT CAP	STAINLESS STEEL PER ASTM-A484 AND ASTM- A582, TYPE 303	PASSIVATE PER ASTM-A380
DIELECTRIC	TFE FLUOROCARBON PER ASTM-D-1457	N/A
CENTER CONTACT	BERYLLIUM COPPER PER ASTM B 196, ALLOY C17300, CONDITION H OR BRASS PER ASTM-B-16	GOLD PLATE PER MIL-G-45204 OVER COPPER PLATE PER MIL-C-14550
RETAINING RING	BERYLLIUM COPPER PER ASTM B 194, ALLOY C17200, CONDITION H	N/A
GASKET	SILICONE RUBBER PER ZZ-R-765	N/A
SHRINK TUBING	HEAT SHRINKABLE POLYOLEFIN COMPOUND MIL-I-23053/4	N/A
FERRULE	COPPER OR BRASS ALLOY ROCKWELL F65 MAXIMUM	GOLD PLATE PER MIL-G-45204 OVER COPPER PLATE PER MIL-C-14550
COMPONENT	MATERIAL	FINISH

ELECTRICAL	MECHANICAL	ENVIRONMENTAL
Nominal Impedance (Ohms) <u>50</u>	Interface Dimensions MIL-STD-348A, Fig. 310.1	TEMPERATURE RATING <u>-65°C TO +125°C</u>
Frequency Range (GHz) <u>DC to MAX</u>	Recommended Mating	Vibration MIL-STD-202, Method 204, Condition D
Operating Frequency of Cable per MIL-C-17	Torque <u>7-10 In-Lbs</u>	Shock MIL-STD-202, Method 213, Condition I
Volt Rating (VRMS MAX) @ Sea Level <u>250</u>	Mating Characteristics:	Thermal Shock MIL-STD-202, Method 107, Condition B, EXCEPT HIGH TEMP +85°C
VSWR <u>1.18+.02f(GHz)</u>	Insertion (MAX Lbs) <u>N/A</u>	Moisture Resistance MIL-STD-202, Method 106
Insertion Loss (dB MAX) <u>.07 f(GHz)</u>	Withdrawal (MIN Oz) <u>N/A</u>	Corrosion - MIL-STD-202, Method 101, Condition B, 5% salt spray
RF Leakage (dB MIN) <u>-(60-fGHz)</u>	Force to Engage and Disengage (In-Lbs MAX) <u>2.0</u>	
Corona, 70,000 Ft (VRMS MIN) <u>190</u>	Center Contact Captivation	
Dielectric Withstanding Voltage (VRMS MIN) @ Sea Level <u>750</u>	Axial (Lbs) <u>6.0</u>	
Contact Resistance (Milliohms MAX)	Radial (In-Oz) <u>4.0</u>	
Center Contact <u>3.0</u>	Cable Retention	
Outer Contact <u>2.0</u>	Axial Force (Lbs) <u>20 Min</u>	
Cable to Housing <u>0.5</u>	Torque (In-Oz) <u>N/A</u>	
RF High Potential @ Sea Level (VRMS MIN @ 5 MHz) <u>500</u>	Weight (Grams) <u>4.2</u>	
I.R.(Megohms MIN) <u>10,000</u>		

THIS DRAWING IS A CONTROLLED DOCUMENT.

DWN	EJC	7/25/68
CHK	BKW	8/13/68
APVD	D.NANIA	10/1/68

tyco Electronics  
Tyco Electronics Corporation  
Harrisburg, PA 17105-3608

NAME: OSM RIGHT ANGLE CABLE  
PLUG-CRIMP ATTACHMENT

SIZE	A2	CAGE CODE	00779	DRAWING NO	C=1052076	RESTRICTED TO	-
WEIGHT	-	SCALE	2:1	SHEET	1 of 1	REV	B

CUSTOMER DRAWING