

APPROVED: _____
 DATE: _____ TITLE: _____

Rev	AWO #	Description	Date	Appr
-		RELEASED	10/29/09	

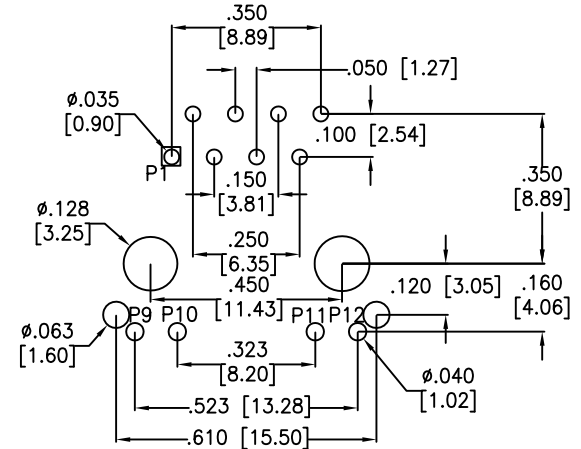
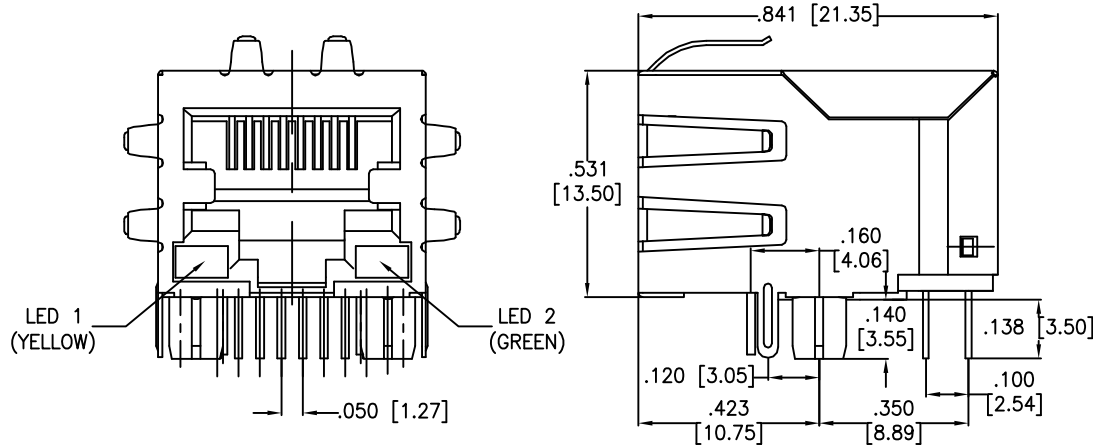

RECOMMENDED PCB LAYOUT

SPECIFICATIONS:

Material:
 Insulator: PBT, glass reinforced, rated UL 94V-0
 Insulator color: Black
 Contacts: Copper Alloy
 Shield: Copper Alloy, Nickel plated

Plating:

Round contact
 Gold over Nickel underplate overall
 Flat contact
 Gold over Nickel underplate on contact area,
 Tin over Nickel underplate on solder tails
 (See chart for thickness)

Electrical:
 Operating voltage: 150 VAC max
 Contact Resistance: 20 mohms max
 Insulation resistance: 500 Mohms min
 Dielectric withstanding voltage: 1000 VAC for 1 minute
 Temperature Rating:
 Operating temperature: 0°C to +70°C
 Environmental:
 Lead free, RoHS compliant.

X	PLATING
0	15 µin Gold
1	30 µin Gold
2	50 µin Gold

UNLESS OTHERWISE SPECIFIED
 ALL DIMENSIONS ARE INCHES [MM]
 TOLERANCES: EXCEPT AS NOTED
 INCHES HOLES
 .X ± .10 Ø.X ± .10
 .XX ± .020 Ø.XX ± .015
 .XXX ± .015 Ø.XXX ± .010

APPROVALS		DATE
DRAWN	DY	10/29/09
CHECKED		
APPROVED		

ADAM TECH

909 Rahway Avenue, Union, NJ 07083
 Phone: 908-687-5000 Fax: 908-687-5710

TITLE
 MODULAR JACK GANGED, 1 PORT, 8P8C
 W/ LED1 YELLOW, LED2 GREEN

SIZE	PART NO.	REV.
X	MTJ-88TX1-FSP-PG-LG-M4	-
REF: S00005C	SCALE: NTS	SHEET 1 OF 2



6

5

4

3

2

1

Rev	AWO #	Description	Date	Appr
		SEE SHT 1 OF 2 FOR REVISION		

APPROVED: _____

DATE: _____ TITLE: _____

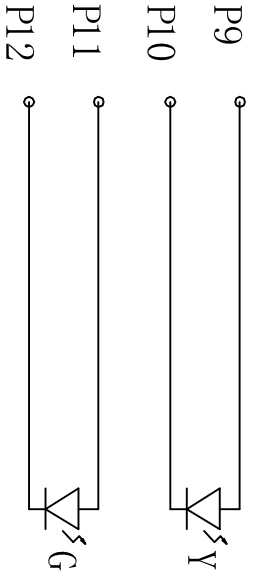
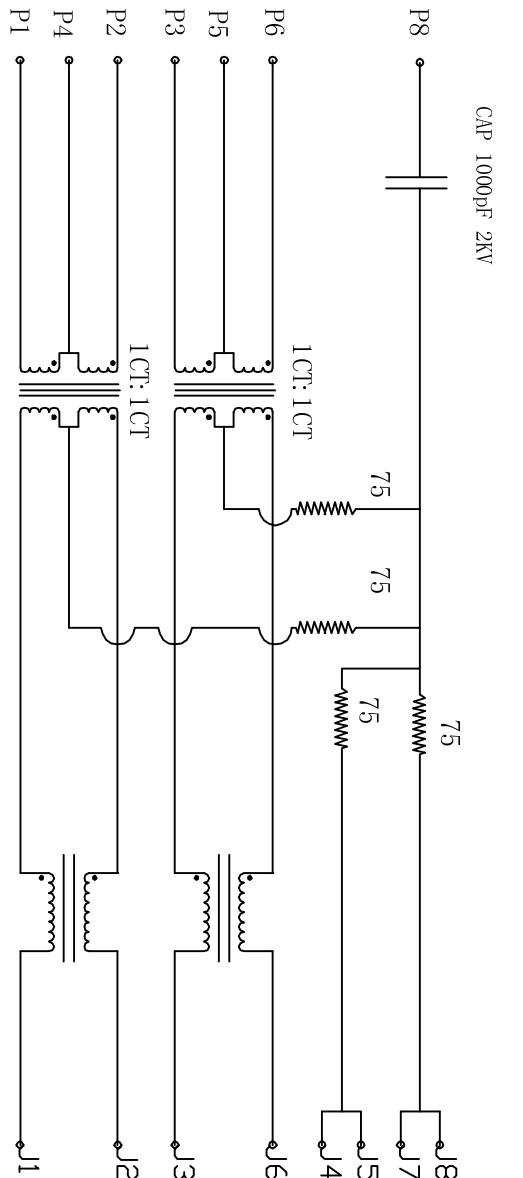

ELECTRICAL SPECIFICATIONS:

- Turns Ratio: (P1 ~ P2) : (J1 ~ J2) 1:1 ±3%
(P3 ~ P6) : (J3 ~ J6) 1:1 ±3%
- Inductance: (P1 ~ P2) 350µH min. @ 0.1V, 100KHZ, 8mA DC Bias
(P3 ~ P6) 350µH min. @ 0.1V, 100KHZ, 8mA DC Bias
- Leakage Inductance: P1 ~ P2 (with J1 and J2 Short): 0.35µH Max. @ 1 MHz
P3 ~ P6 (with J3 and J6 Short): 0.35µH Max. @ 1 MHz
- Interwinding Capacitance: (P1 ~ P2) : (J1 ~ J2): 35pF max. @ 1MHZ
(P3 ~ P6) : (J3 ~ J6) : 1.2 Ohms Max.
- DC Resistance: (J1 ~ J2):(J3 ~ J6) :1.2 Ohms Max.
- Return Loss: 1MHZ to 30MHZ: -18dB min / 30MHZ to 80MHZ: -12dB min
- Dielectric Withstanding: (P1~P2) : (J1~J2) :1500VAC
(P3~P6) : (J3~J6) :1500VAC
- Insertion Loss: RS=RL=1000OHM : 100KHZ TO 80MHZ : -1.1dB Min.
- Cross Talk: 1MHZ to 100MHZ: 35dB Typ.
- Common to Common mode Attenuation 30MHZ to 100MHZ: 30dB Typ.

ADAM TECH

909 Rahway Avenue, Union, NJ 07083
Phone: 908-687-5000 Fax: 908-687-5710

MODULAR JACK GANGED, 1 PORT, 8P8C
W/ LED1 YELLOW, LED2 GREEN

UNLESS OTHERWISE SPECIFIED ALL DIMENSIONS ARE INCHES [MM]		TOLERANCES: EXCEPT AS NOTED	
.X	± .10	Ø.X	± .10
.XX	± .020	Ø.XXX	± .015
.XXX	± .015	Ø.XXXX	± .010
APPROVALS		DATE	
DRAWN	DY	10/29/09	
CHECKED			
APPROVED			
SIZE	PART NO.	REV.	
X	MTJ-88TX1-FSP-PG-LG-M4		
REF:	S00003C	SCALE:	NTS
SHEET 2 OF 2			