

THIS DRAWING IS UNPUBLISHED. RELEASED FOR PUBLICATION  
 © COPYRIGHT BY TYCO ELECTRONICS CORPORATION. ALL RIGHTS RESERVED.

LOC	DIST	REVISIONS			
P	LTR	DESCRIPTION	DATE	DWN	APVD
G	14	E	REDRAWN PER 0G3A-0603-03	03OCT03	JR MS

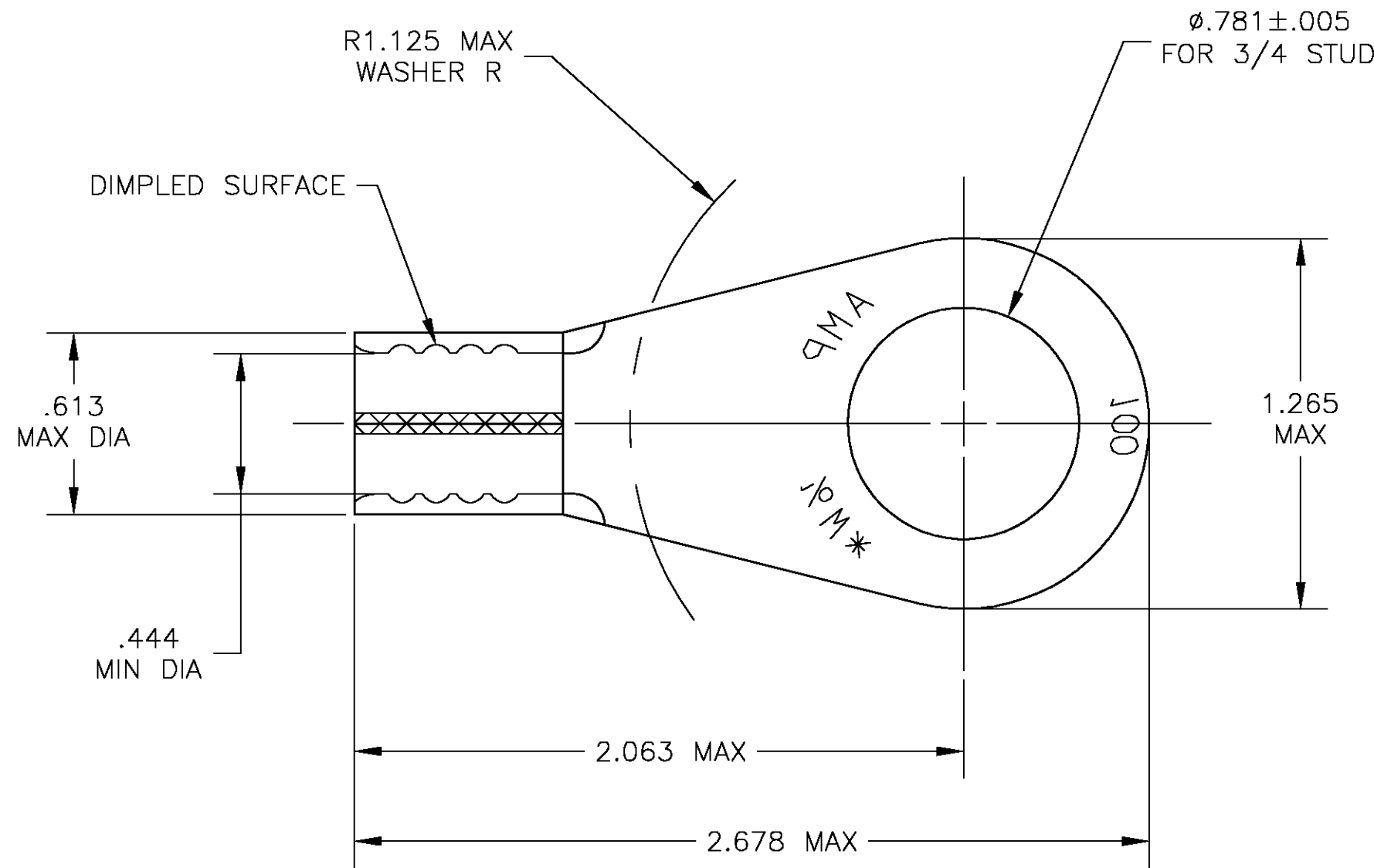

- 1 TONGUE THK IS .070±.003
- △ 2 TIN PLATE PER ASTM B 545 ANNEALED

320748-0  
 PART NO

THIS DRAWING IS A CONTROLLED DOCUMENT.		DWN jr_ruth 03OCT03	Tyco Electronics Corporation Harrisburg, PA 17105		
DIMENSIONS: INCHES 		CHK MJ SPICER 03OCT03			
TOLERANCES UNLESS OTHERWISE SPECIFIED: 0 PLC ± - 1 PLC ± - 2 PLC ± - 3 PLC ± .008 4 PLC ± - ANGLES ± 5°		APVD MJ SPICER 03OCT03	NAME		
MATERIAL COPPER ASTM B152		FINISH - △ 2	PRODUCT SPEC - APPLICATION SPEC - WEIGHT -		
CUSTOMER DRAWING			SIZE A3	CAGE CODE 00779	DRAWING NO C-320748
			RESTRICTED TO -	SCALE 2:1	SHEET 1 OF 1
			REV E		