

# 10/100 Base-TX Single Port SMD LAN Transformer Module



ALANM100X1



12.0 x 9.4 x 5.0 mm  
RoHS/RoHS II Compliant  
MSL = 1

## Features

- Uniform transformer windings
- Fully automated production lines
- Standard 1.27mm pin pitch
- Lead-less SMD construction resistant to tin whiskering
- Meets IEEE 802.3u standard
- Multiple schematic and pinout options
- High performance magnetics for EMI suppression and common mode noise rejection
- 5.0mm height

## Applications

### Communications

- Servers
- Switches
- Routers

### Commercial/Industrial

- Video surveillance
- VoIP & IP telecommunications
- Transaction machines
- WiFi gateways

### IoT/Consumer

- Smart Lighting
- Smart Appliance

## Part Identification

ALANM100X1 -

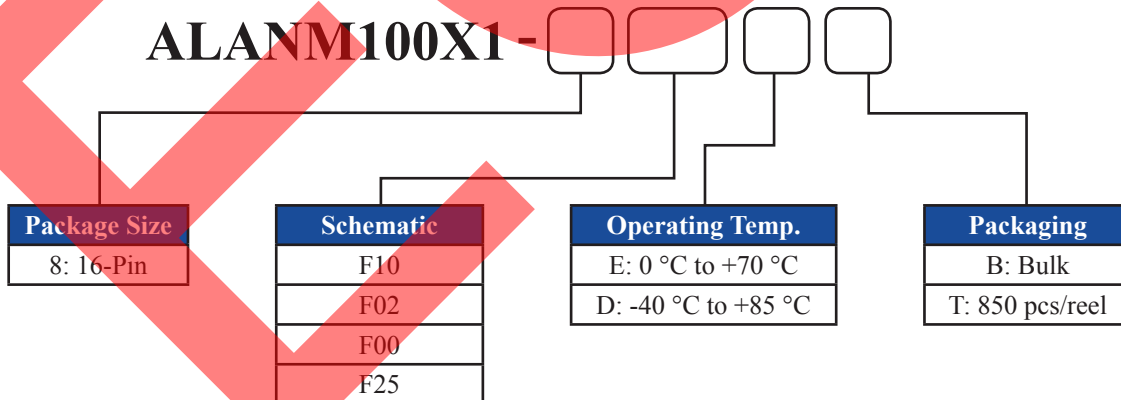

# 10/100 Base-TX Single Port SMD LAN Transformer Module



ALANM100X1



12.0 x 9.4 x 5.0 mm  
RoHS/RoHS II Compliant  
MSL = 1

## Electrical Specifications at 25°C

Part Number	Insertion Loss (dB Max)	Return Loss (dB Min)				Crosstalk (dB Min)			CM to CM Rejection Ratio (dB Min)			DM to CM Rejection Ratio (dB Min)		
	0.5-100 MHz	1-40 MHz	60 MHz	80 MHz	100 MHz	0.5-40 MHz	60 MHz	100 MHz	30 MHz	60 MHz	100 MHz	30 MHz	60 MHz	100 MHz
ALANM100X1-8F10	1.5	16	14	12	10	40	37	33	42	37	33	42	37	33
ALANM100X1-8F02	1.5	16	14	12	10	40	37	33	42	37	33	42	37	33
ALANM100X1-8F00	1.5	16	14	12	10	40	37	33	42	37	33	42	37	33
ALANM100X1-8F25	1.5	16	14	12	10	40	37	33	42	37	33	42	37	33

Part Number	Inductance (uH Min)	Leakage Inductance (uH)	Hi Pot (VDC)	Weight (g)
Test Condition	@100kHz, 0.2V, 8mA DC Bias	@ 100kHz Td to Mx	6 sec.	Per Piece
ALANM100X1-8F10	200	0.5	1500	0.95
ALANM100X1-8F02	200	0.5	1500	0.95
ALANM100X1-8F00	200	0.5	1500	0.95
ALANM100X1-8F25	200	0.5	1500	0.95

# 10/100 Base-TX Single Port SMD LAN Transformer Module



ALANM100X1



12.0 x 9.4 x 5.0 mm  
RoHS/RoHS II Compliant  
MSL = 1

## Mechanical Dimensions

8: 16-pin

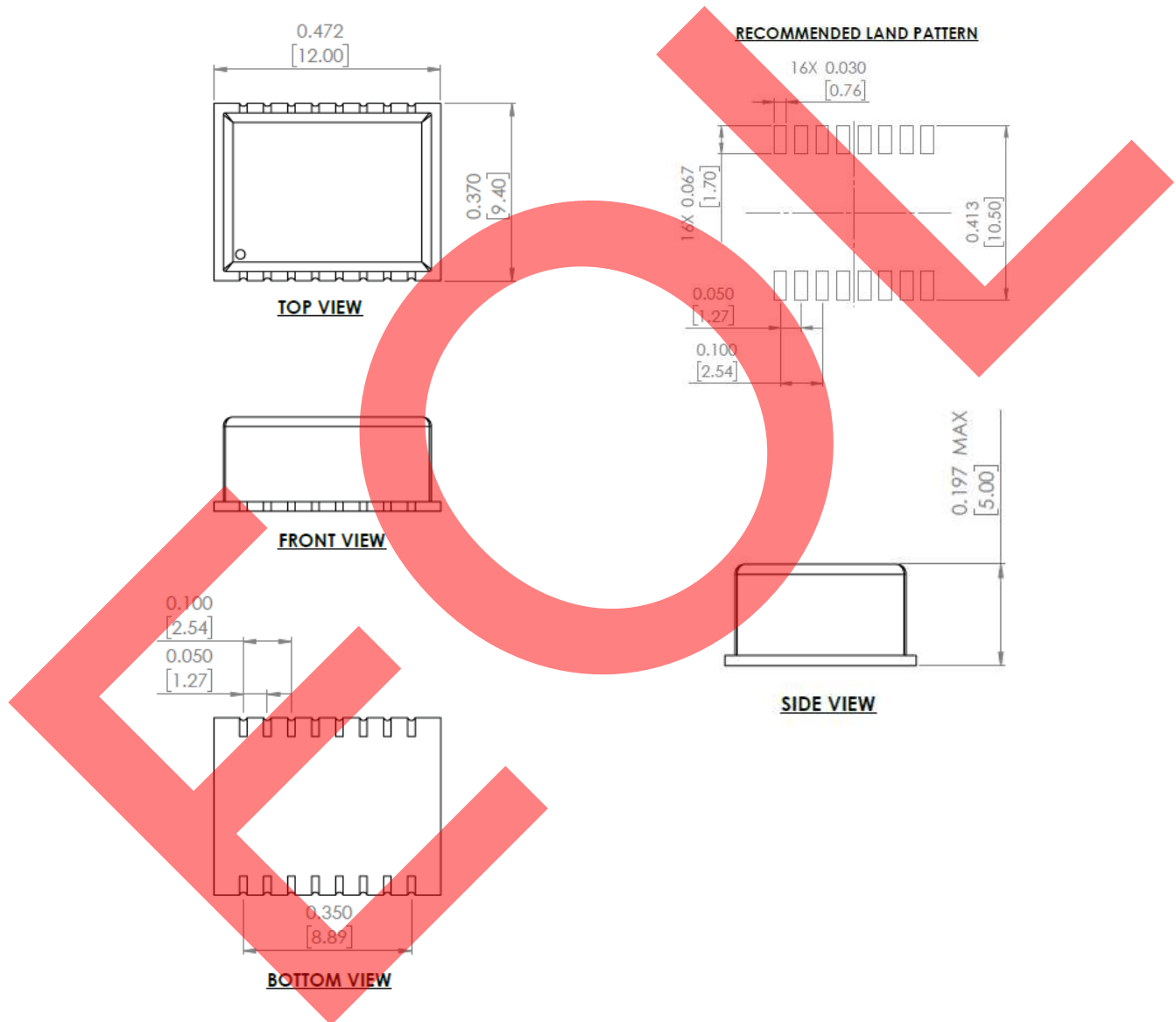

Unless otherwise specified, all tolerances are  $\pm 0.25$  in mm  
Dimensions: mm



5101 Hidden Creek Ln Spicewood TX 78669  
Phone: 512-371-6159 | Fax: 512-351-8858  
For terms and conditions of sales, please visit:  
[www.abracon.com](http://www.abracon.com)

REVISED: 05-6-19

ABRACON IS  
ISO9001-2015  
CERTIFIED

# 10/100 Base-TX Single Port SMD LAN Transformer Module



ALANM100X1



12.0 x 9.4 x 5.0 mm  
RoHS/RoHS II Compliant  
MSL = 1

## Schematics

### 16-pin

F10

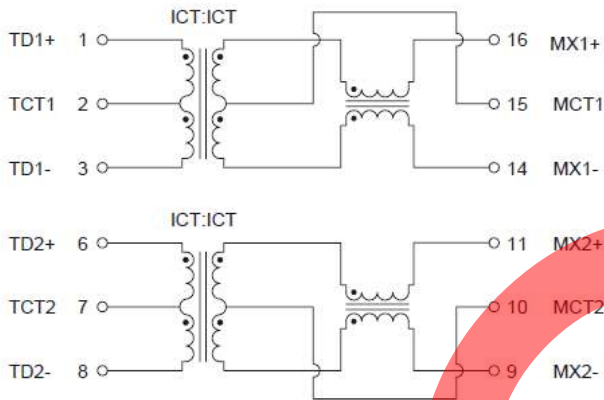

F00

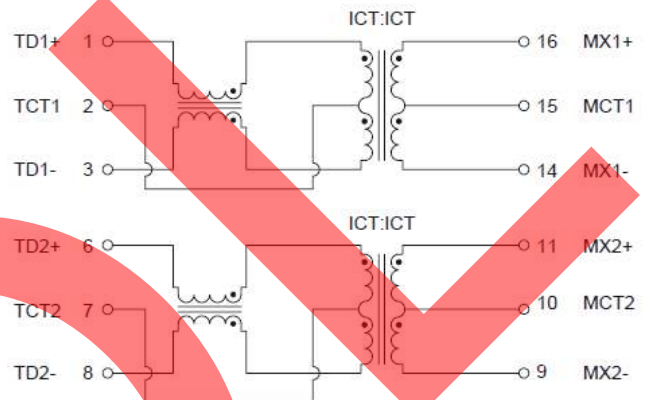

F02

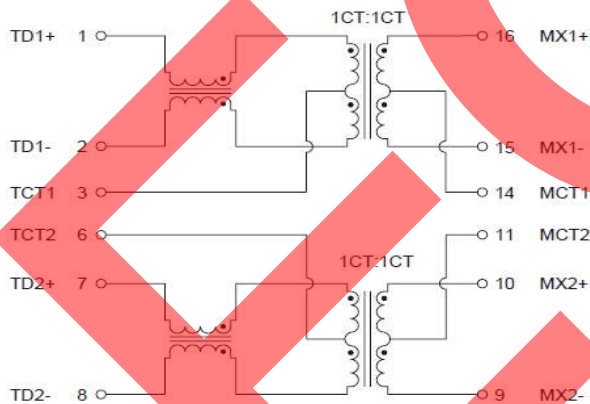

F25

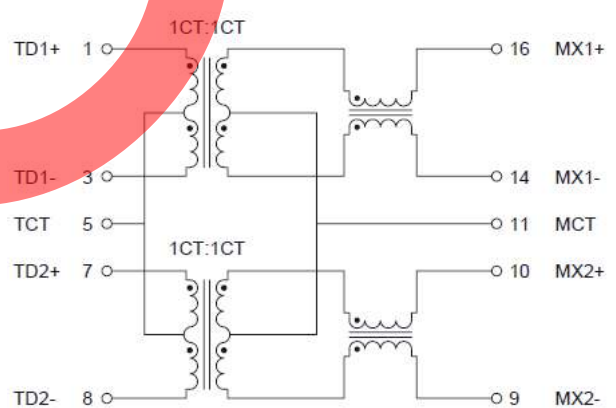

# 10/100 Base-TX Single Port SMD LAN Transformer Module



ALANM100X1



12.0 x 9.4 x 5.0 mm  
RoHS/RoHS II Compliant  
MSL = 1

## Reflow Profile

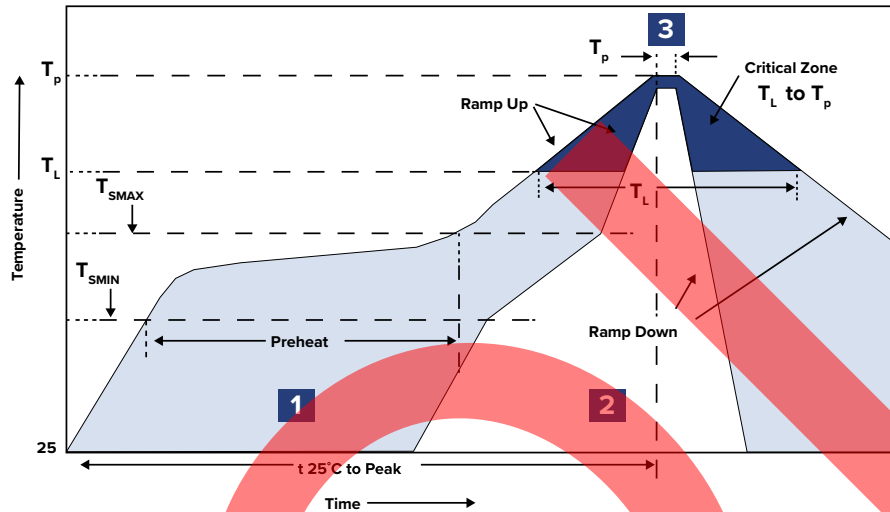

Zone	Description	Temperature	Time
1	Preheat / Soak	$T_{SMIN} \sim T_{SMAX}$ 150°C ~ 200°C	60 ~ 180 sec.
2	Reflow	$T_L$ 245°C	20 ~ 40 sec.
3	Peak heat	$T_P$ 260°C ± 5°C	10 sec. MAX

## Packaging

T = 850 pcs/reel

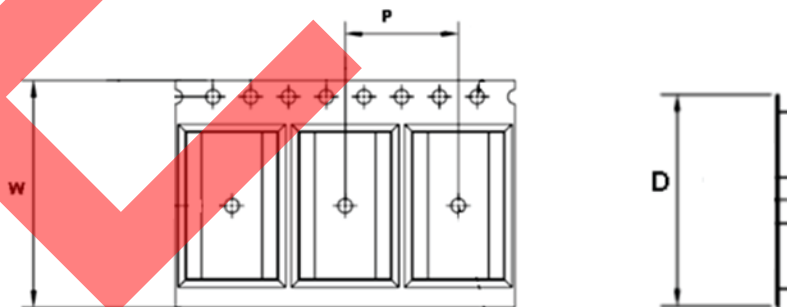

W	P	D
24.0	16.0	Ø330

Dimensions: mm



5101 Hidden Creek Ln Spicewood TX 78669  
Phone: 512-371-6159 | Fax: 512-351-8858  
For terms and conditions of sales, please visit:  
[www.abracon.com](http://www.abracon.com)

REVISED: 05-6-19

ABRACON IS  
ISO9001-2015  
CERTIFIED