

# SACB-8/ 8-L-M23 - Sensor/actuator box



1692446

<https://www.phoenixcontact.com/us/products/1692446>

Please be informed that the data shown in this PDF document is generated from our online catalog. Please find the complete data in the user documentation. Our general terms of use for downloads are valid.



Sensor/actuator box, application: Standard, connection method: M12 socket Plastic, number of slots: 8, number of positions: 4, coding: A, slot assignment: single, status display: Yes, pnp; master cable connection: M23 plug connection 90°, shielding: no

## Your advantages

- Safety in the field, thanks to molded housing and high degree of protection
- Convenient: increased machine availability thanks to quick and easy diagnostics

## Commercial data

Item number	1692446
Packing unit	1 pc
Minimum order quantity	1 pc
Sales key	BF41
Product key	BF3CBB
Catalog page	Page 114 (PC-2009)
GTIN	4017918177904
Weight per piece (including packing)	153.9 g
Weight per piece (excluding packing)	135 g
Customs tariff number	85366990
Country of origin	DE

# SACB-8/ 8-L-M23 - Sensor/actuator box



1692446

<https://www.phoenixcontact.com/us/products/1692446>

## Technical data

### Notes

General	<b>NOTE:</b> Observe the permissible bending radii when laying conductors, since the degree of protection may be put in jeopardy if the bending forces are too high. Alleviate mechanical loads upstream of the connector, e.g. by using cable ties.
General	Unused slots are to be sealed off prior to commissioning. Suitable sealing elements are to be found under "Accessories".

### Product properties

Product type	Distributor boxes with M8 to M12 slots
Number of positions	4
Application	Standard
Number of slots	8
Coding	A
LED	yes

### Material specifications

Material	PA
	PA
Flammability rating according to UL 94	V0
Seal material O-ring	NBR
Contact material	CuSn
Contact surface material	Ni/Au
Contact carrier material	PA
Material of contact, master cable side	CU alloy
Material of contact surface, master cable side	gold-plated

### Dimensions

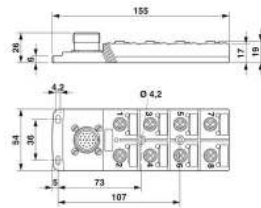
Dimensional drawing	
Width	54 mm
Height	26 mm
Length	155 mm

### Connection data

Conductor connection	
Connection method	M23 plug connection

# SACB-8/ 8-L-M23 - Sensor/actuator box



1692446

<https://www.phoenixcontact.com/us/products/1692446>

Tightening torque slot sensor/actuator cable	0.4 Nm
--	--------

## Pin assignment

Slot/position = Wire color or connection	1 / 4 (A) = 1
	2 / 4 (A) = 2
	3 / 4 (A) = 3
	4 / 4 (A) = 4
	5 / 4 (A) = 5
	6 / 4 (A) = 6
	7 / 4 (A) = 7
	8 / 4 (A) = 8
	1-8 / 1 (+ 24 V) = 11
	1-8 / 3 (0 V) = 9+10
1-8 / 5 (PE) = 12	

## Signaling

Status display present	Yes
------------------------	-----

## Electrical properties

Max. operating voltage $U_{max}$	30 V DC
Local diagnostics	Supply voltage Green LED
	Status display I/O Yellow LED
Nominal voltage $U_N$	24 V DC
Rated current, total	12 A
Max. current carrying capacity per path	2 A
Current carrying capacity per slot	4 A

## Cable/line

Sensor/actuator connection system	M12 socket
Connection method	M23 plug connection
Tightening torque slot sensor/actuator cable	0.4 Nm

## Environmental and real-life conditions

### Ambient conditions

Degree of protection	IP65
	IP67
Ambient temperature (operation)	-20 °C ... 75 °C

# SACB-8/ 8-L-M23 - Sensor/actuator box





1692446

<https://www.phoenixcontact.com/us/products/1692446>

## Approvals

To download certificates, visit the product detail page: <https://www.phoenixcontact.com/us/products/1692446>

 <b>cUL Recognized</b> Approval ID: FILE E 118976				
	Nominal voltage $U_N$	Nominal current $I_N$	Cross section AWG	Cross section $mm^2$
	24 V	-	22 - 16	-

 <b>UL Recognized</b> Approval ID: FILE E 118976				
	Nominal voltage $U_N$	Nominal current $I_N$	Cross section AWG	Cross section $mm^2$
	24 V	-	22 - 16	-

<b>cULus Recognized</b>				
-------------------------	--	--	--	--

# SACB-8/ 8-L-M23 - Sensor/actuator box



1692446

<https://www.phoenixcontact.com/us/products/1692446>

## Classifications

### ECLASS

ECLASS-11.0	27440111
ECLASS-12.0	27440111
ECLASS-13.0	27440111

### ETIM

ETIM 8.0	EC003558
----------	----------

### UNSPSC

UNSPSC 21.0	31251500
-------------	----------

# SACB-8/ 8-L-M23 - Sensor/actuator box



1692446

<https://www.phoenixcontact.com/us/products/1692446>

## Environmental product compliance

REACH SVHC	Lead 7439-92-1
China RoHS	Environmentally Friendly Use Period = 50 years
	For information on hazardous substances, refer to the manufacturer's declaration available under "Downloads"

Phoenix Contact 2023 © - all rights reserved  
<https://www.phoenixcontact.com>

Phoenix Contact USA  
586 Fulling Mill Road  
Middletown, PA 17057, United States  
(+717) 944-1300  
[info@phoenixcon.com](mailto:info@phoenixcon.com)