

SERIES

NO.OF CONTACTS

09,15,25,37

TYPE OF CONTACTS

P-PIN

TYPE OF TERMINATION

13-ANGLED SPILL

PITCH 2.54

FOOT PRINT 10.40 EUROPE

HEIGHT OF TERMINATION

A-2.00mm COMPATIBLE FOR 1.6mm PCB

RoHS INFORMATIONS

"This LF product meets European Union Directives and other country regulations as described in GS-22-008"

The housing will withstand exposure to 260°C peak temperature for 30 seconds in a convection,infra-red or vapor reflow oven solder application.

Packaging as per GS-14-920

PRODUCT SPECIFICATION

See :- GS-12-433

PACKAGING SPECIFICATION

See :- GS-14-1157

SEE NOTE RoHS

PACKAGING SPECIFICATION

09-TRAY PACKAGING

MOUNTING OPTIONS

RV->LIF METAL PEG+F.SCREW LOCK UNC 4 40+METAL BRACKET

RL->LIF METAL PEG+ INSERT M3+METAL BRACKET

RX->LIF METAL PEG+ INSERT UNC 4-40 +METAL BRACKET

PLATING

6-500 Mating/Un-mating performance



Copyright FCI

mat'l. code SEE.TECH.SPEC				surface ISO 1302 <input checked="" type="checkbox"/>		tolerance ISO 406 ISO 1101		projection 		product family DELTA-D			
ltr				ecn no		dr		date		title			
A				107-0167		AS		2007-12-04		DELTA-D A/S MALE PIP CONNECTOR EUROPE VERSION			
B				108-0175		AS		2008-12-23		MM scale -			
C				109-0162		AS		2009-08-17					
				angles		linear		.00±0.1		dwg no G-DD-0103 sheet 1 of 2 size A3			
				0°±1°				.000±.00X					
				dr		ANSHSALAM		2007-12-04					
				engr		ANSHSALAM		2009-08-17					
				chr		ANSHSALAM		2009-08-17		type Product Customer Drawing			
				appd		ANSHSALAM		2009-08-17					
sheet index		revision sheet		C		C							
		1		2									

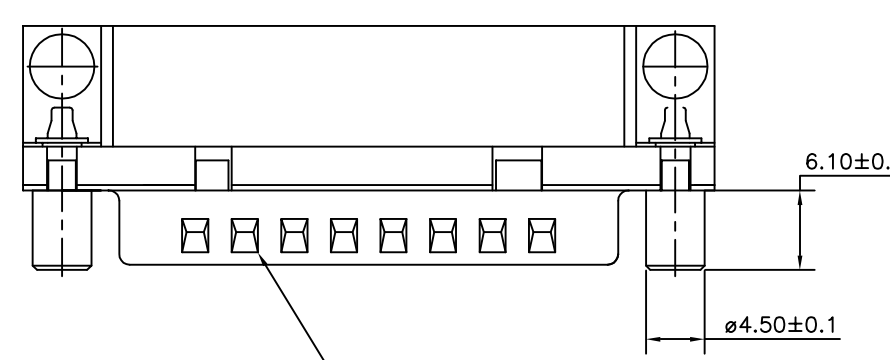

37	69.32	63.50	55.30	49.68	5.70	+0.25 -0
25	53.03	47.04	38.84	33.12	5.70	+0.25 -0
15	39.14	33.32	25.12	19.18	5.90	+0.15 -0
09	30.81	24.99	16.79	10.96	5.90	+0.15 -0
SHELL	A	B	D	E	G	

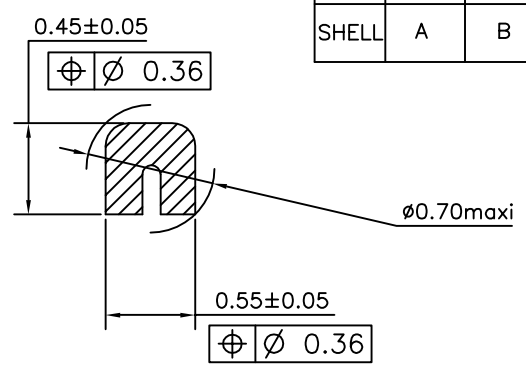
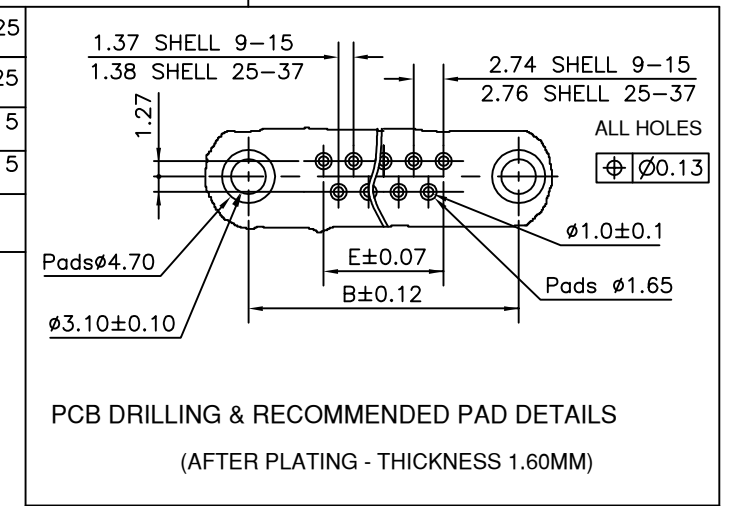

SECTION A-A

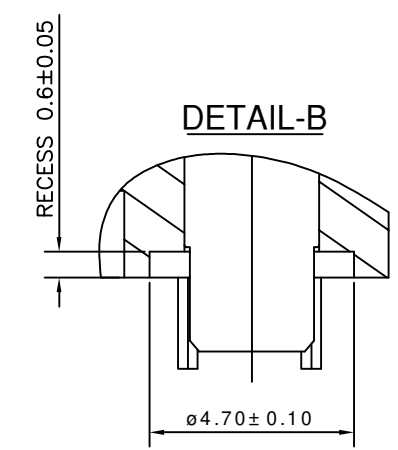
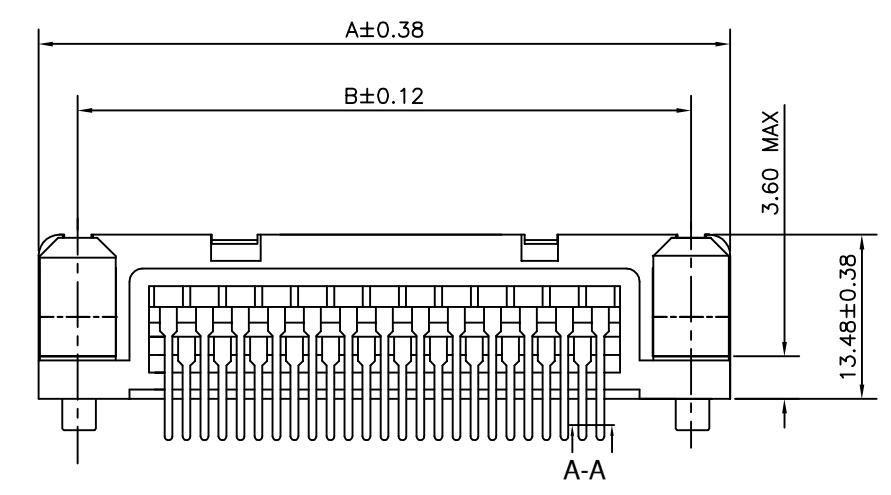
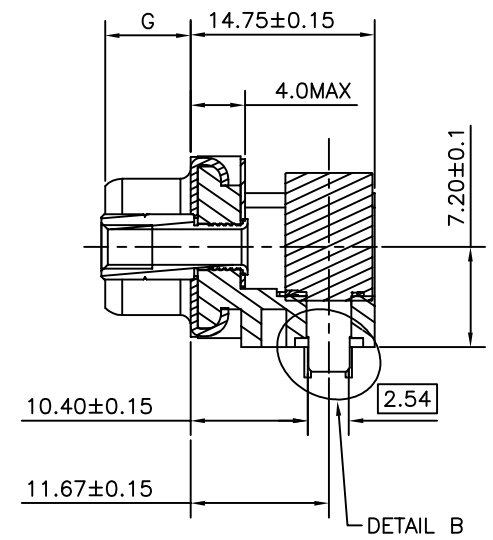
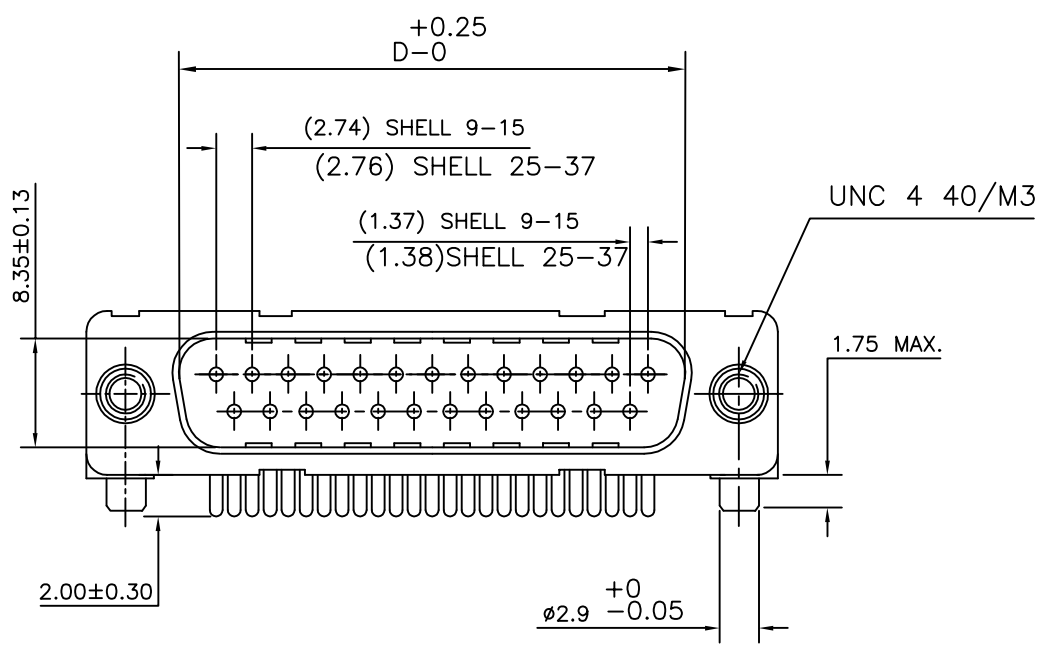

ACCESSORIES DETAILS

TRUE POSITIONING : ϕ 0.36

RV VERSION

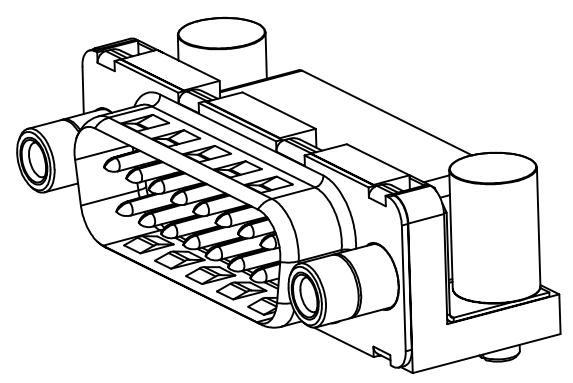

RX/RL VERSION

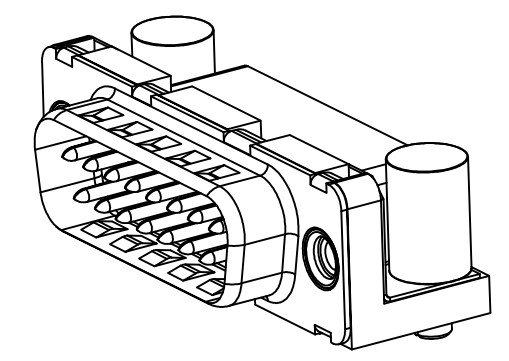

mat'l. code SEE.TECH.SPEC				surface ISO 1302 ✓		tolerance ISO 406 ISO 1101		projection 		product family DELTA-D	
ltr				ecn no		dr		date		title	
A				107-0167		AS		2007-12-04		DELTA-D A/S MALE PIP CONNECTOR EUROPE VERSION	
B				108-0175		AS		2008-12-23		MM	
C				109-0162		AS		2009-08-17		scale -	
				dr		ANSHSALAM		2007-12-04		dwg no	
				engr		ANSHSALAM		2009-08-17		sheet 2 of 2	
				chr		ANSHSALAM		2009-08-17		size	
				appd		ANSHSALAM		2009-08-17		A3	
sheet index		revision sheet		C		C				type	
		1		2						Product Customer Drawing	