

C30724 Series

Stable Gain Silicon Avalanche Photodiode (APD) for High Volume Range Finding



Excelitas' C30724 series avalanche photodiode is designed for operation at gains in the range 10 to 20. The operating voltage range is 120 to 200 Volts, and in many applications, the APD can be operated at a fixed bias voltage, without the need for temperature compensation.

The C30724 series APDs provide high responsivity in the wavelength range 800 to 950 nm, and rise and fall times of about 5 ns, with no "tail" in the fall time characteristic. They are particularly suited for high volume applications such as Laser Range Finding, Optical Communication Systems and other applications requiring high speed and low noise.

These APDs come in three different packages, designed to meet the needs of high volume and low cost applications.

The C30724EH is in a hermetically sealed TO-18 can. The C30724EH-2 is a modified TO-18 with a built in 905 nm narrow band pass filter. The C30724PH is in a TO-18 plastic encapsulated package.

As the C30724 series intended use is for large volume applications, it is often offered in pair with Excelitas' high volume plastic encapsulated 905 nm pulsed laser diodes PGEW, DPGEW and TPGEW series. Please inquire about our large volume APD and Pulse Laser pair pricing for your specific application.

Key Features

- High Quantum Efficiency: 75% @ 900 nm
- Low Capacitance: ≤ 1 pF
- Low Operating Voltage: 120 V to 200 V
- Fast Time Response : Typically 5 ns
- High Bandwidth
- Low Noise
- Hermetically Sealed, Built-in Filter, and Plastic encapsulated Packages
- Low cost
- ROHS Compliant

Applications

- Range Finding
- Laser Meter
- Distance Measurement
- Optical communication

Table 1. Mechanical and Optical Characteristics

	C30724EH	C30724EH-2	C30724PH	Unit
Shape	Circular	Circular	Circular	
Useful Area	0.2	0.2	0.2	mm ²
Useful Diameter	0.5	0.5	0.5	mm
Package	TO-18 Hermetic	TO-18 with Filter	TO-18 Plastic	

Table 2. Typical Electrical Characteristics at T_A = 22 °C

Parameter	C30724EH			C30724EH-2			C30724PH			Unit
	Min	Typ	Max	Min	Typ	Max	Min	Typ	Max	
Breakdown Voltage, V _{BR}	-	350	-	-	350	-	-	350	-	V
Operating Voltage, V _{op}	150		200	150		200	150		200	V
Gain (M) @ 900nm	12	15	18	12	15	18	12	15	18	
Total Dark Current, I _d	-	20	-	-	20	-	-	20	-	nA
Noise Current, i _n f=10kHz, Δf=1.0Hz	-	0.1	0.25	-	0.1	0.25	-	0.1	0.25	pA/√Hz
Capacitance, C _d	-	1.0	-	-	1.0	-	-	1.0	-	pF
Rise & Fall Time, R _L =50 Ω, 10%-90%-10% points	-	5	-	-	5	-	-	5	-	Ns
Maximum Forward Current	-	-	5	-	-	5	-	-	5	mA
Power Dissipation	-	-	60	-	-	60	-	-	60	mW
Storage Temperature	-60		+100	-60		+100	-40		+100	°C
Operating Temperature	-40		+70	-40		+70	-10		+60	°C

Low Cost – High Volume Stable Gain Silicon Avalanche Photodiode

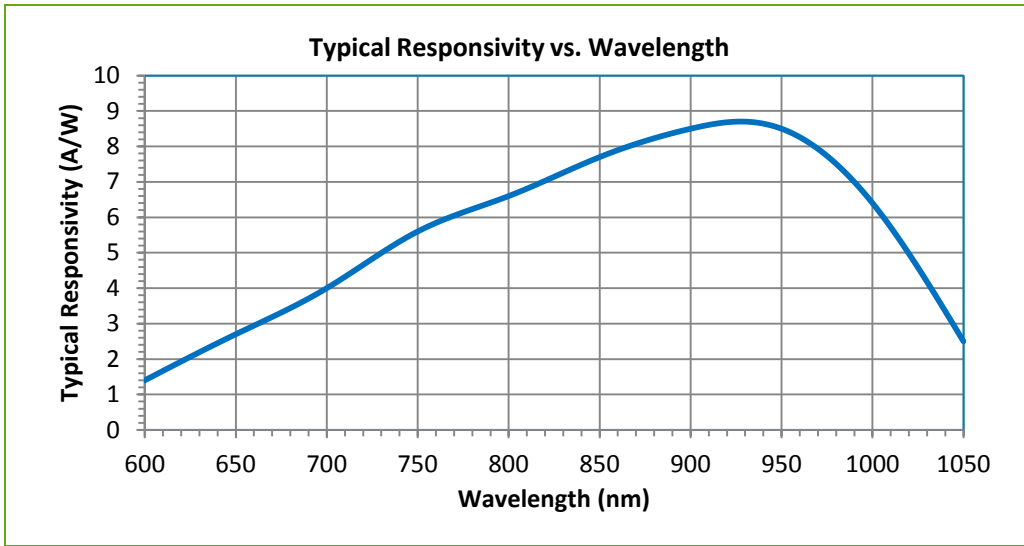

Figure 1
Typical Responsivity vs. Wavelength for C30724EH and C30724PH type

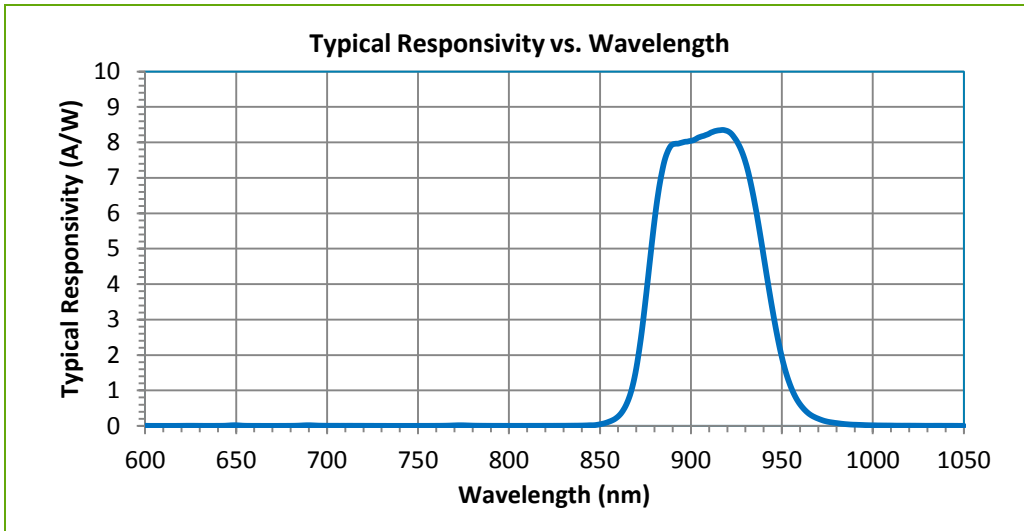

Figure 2
Typical Responsivity vs. Wavelength for C30724EH-2

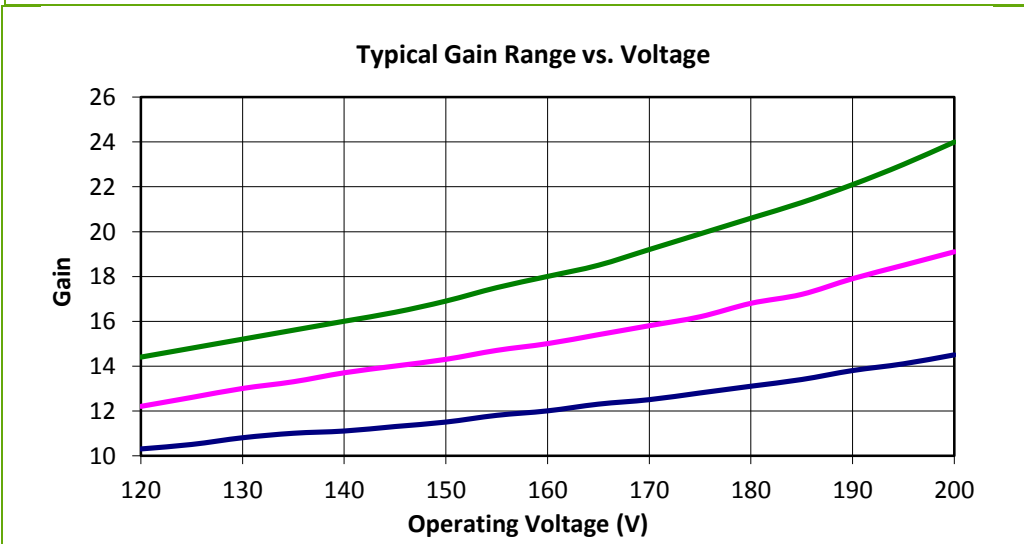

Figure 3
Typical Gain Range vs. Voltage

Low Cost – High Volume Stable Gain Silicon Avalanche Photodiode

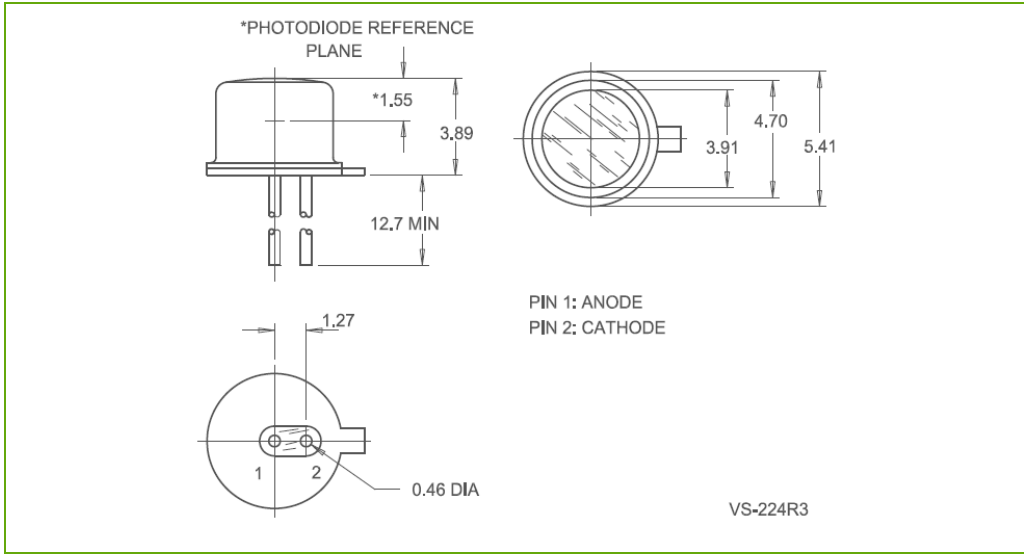

Figure 4
C30724EH package dimension

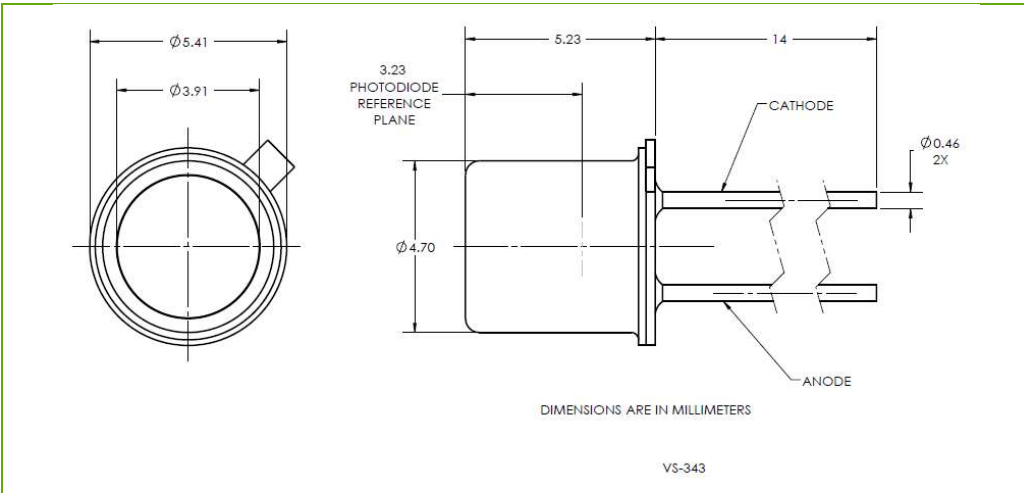

Figure 5
C30724EH-2 Package dimension

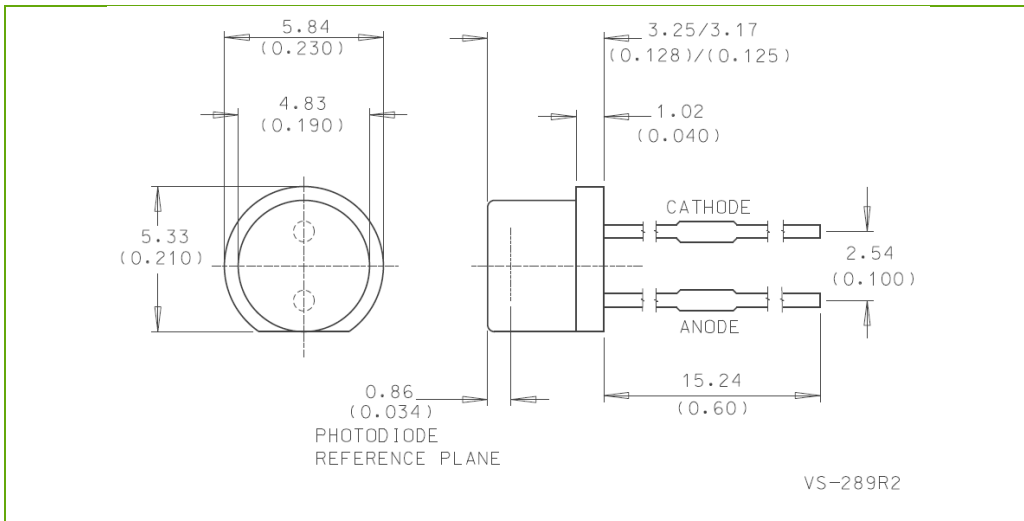

Figure 6
C30724PH Package dimension

C30724 Series

Low Cost – High Volume Stable Gain Silicon Avalanche Photodiode

ESD warning

APDs should only be handled at an ESD-safe work station.

RoHS Compliance

This series of APDs are designed and built to be fully compliant with the European Union Directive European Union Directive 2011/65/EU – Restriction of the use of certain Hazardous Substances (RoHS) in Electrical and Electronic equipment.



Warranty

A standard 12-month warranty following shipment applies. Any warranty is null and void if the photodiode window has been opened.

About Excelitas Technologies

Excelitas Technologies is a global technology leader focused on delivering innovative, customized solutions to meet the lighting, detection and other high-performance technology needs of OEM customers.

Excelitas has a long and rich history of serving our OEM customer base with optoelectronic sensors and modules for more than 45 years beginning with PerkinElmer, EG&G, and RCA. The constant throughout has been our innovation and commitment to delivering the highest quality solutions to our customers worldwide.

From analytical instrumentation to clinical diagnostics, medical, industrial, safety and security, and aerospace and defense applications, Excelitas Technologies is committed to enabling our customers' success in their specialty end-markets. Excelitas Technologies has approximately 3,000 employees in North America, Europe and Asia, serving customers across the world.

Excelitas Technologies
22001 Dumberry Road
Vaudreuil-Dorion, Quebec
Canada J7V 8P7
Telephone: (+1) 450 424 3300
Toll-free: (+1) 800 775 6786
Fax: (+1) 450 424 3345
detection@excelitas.com

**Excelitas Technologies
GmbH & Co. KG**
Wenzel-Jaksch-Str. 31
D-65199 Wiesbaden
Germany
Telephone: (+49) 611 492 430
Fax: (+49) 611 492 165
detection.europe@excelitas.com

Excelitas Technologies Singapore, Pte. Ltd.
8 Tractor Road
Singapore 627969
Telephone: (+65) 6775 2022 (Main number)
Telephone: (+65) 6770 4366 (Customer Service)
Fax: (+65) 6778-1752
detection.asia@excelitas.com



For a complete listing of our global offices, visit www.excelitas.com/ContactUs

© 2011 Excelitas Technologies Corp. All rights reserved. The Excelitas logo and design are registered trademarks of Excelitas Technologies Corp. All other trademarks not owned by Excelitas Technologies or its subsidiaries that are depicted herein are the property of their respective owners. Excelitas reserves the right to change this document at any time without notice and disclaims liability for editorial, pictorial or typographical errors.