

REVISION RECORD				
REV	ECO	DESCRIPTION	DRFT	CHKD
△		ADD P/N.	DT	05/06/05
△		ADD P/N.	HERO	10/18/05
△		ADD P/N.	HERO	11/3/05

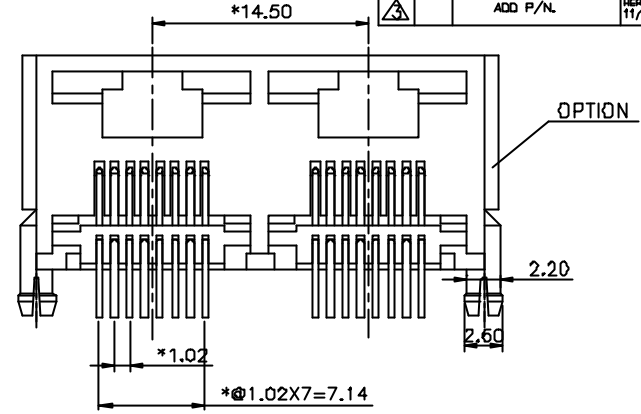

SECTION A-A

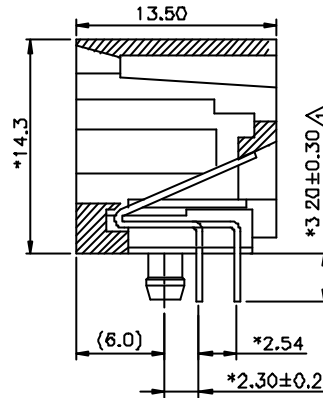
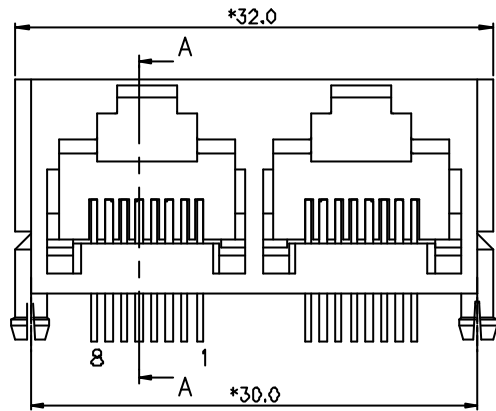
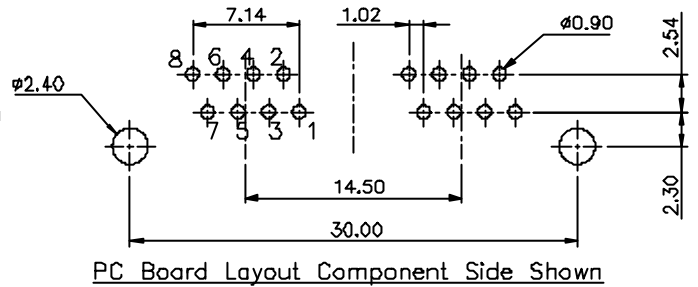

NOTES:

ELECTRICAL:

1. VOLTAGE RATING : 125 VAC RMS.
2. CURRENT RATING : 1.5 AMP.
3. CONTACT RESISTANCE : 30 MILLIOHMS MAX.
4. INSULATION RESISTANCE: 1000 MEGOHMS MIN @ 500 VDC.
5. DIELECTRIC STRENGTH : 1000 VAC RMS 60HZ, 1MIN.

MECHANICAL:

1. HOUSING MATERIAL : PBT+30%GF UL94V-0
2. INSERT MATERIAL : PBT+30%GF UL94V-0
3. CONTACT MATERIAL : PHOSPHOR BRONZE Ø0.46mm.
4. PLATING : GOLD PLATING OVER NICKEL.
5. OPERATING LIFE : 750 CYCLES MIN.
6. PCB RETENTION PRE-SOLDER : 1 LB MIN.
7. PCB RETENTION POST-SOLDER. 10 LBS MIN.

ENVIRONMENTAL:

1. STORAGE : -40°C TO +85°C.
2. OPERATION: 0°C TO 70°C.
3. WAVE SOLDERING TEMPERATURE: 230~250° (3~5 SECONDS)

MATES WITH MODULAR PLUG CONFORMING TO

FCC PART 68, SUBPART F.

CUL FILE NO E163191

FREE LEAD PART NUMBER: E558X-20AXXX-L

NO. OF CONTACT: 2- 2C 4- 4C 6- 6C 8- 8C	1- 3u" 2- 6u" 3- 15u" 4- 30u" 5- 50u" 6- Pd 20u"	1- WITH PANEL STOP 2- W/O PANEL STOP 4- W/ THREE MERELY PANEL STOP △ 5- W/O THREE MERELY PANEL STOP △
---	--	--

5-A06-0080
 △ D-A06-2380
 △ K-A05-0220

昵夕口厂
 ZWCAD 2004 刚ノ
 岡簿叫瑞弊WWW.ZWCAD.COM

DETACHED LIST	MM (INCH)	DFTO YAN	DATE 03/28/05
	TOLERANCES EXCEPT AS NOTED	CHKD	DATE
		WFO	DATE
		APPL DRDGR	DATE 11/05/05
	MATERIAL :		
	ANGLES ± 0.5	QTY :	
	THIRD ANGLE PROJECTION	FINISH	
		SCALE : 3 : 1	

FULL RISE ELECTRONIC CO., LTD			
TITLE			
MINI L/P DUAL PORT 8P			
DRAWING NO GE553037-LC		SIZE	REV
/PART NO SEE NOTE		A3	3
DO NOT SCALE DRAWING		SHEET	OF