

CCM04 MK III Miniature Connectors



Introducing a new range of CCM04 connectors designed to interface with either full or SIM/SAM smart cards and designed to minimize space usage on the PCB .

Features

- Available with 6 or 8 contacts.
- The contact area is spooned to reduce the risk of accidental (or deliberate) damage and to optimize the electrical connection with the card.
- The insulators, molded from high temperature thermoplastic, are suited for infrared and convection soldering processes.
- With tape and reel packaging as standard, the connectors are designed to be automatically pick and placed.

Construction

Insulator	High temperature thermoplastic UL 94V-0
Contacts	Copper Alloy
Contact finish	Gold over nickel
PC Tail plating	Tin lead (2 μ m min)

Mechanical Data

Mechanical life	50,000 cycles minimum
Contact force	0.25 N min / 0.5 N max
Contact travel	0,75mm

Electrical Contacts Data

Insulation resistance	1000 M Ω min
Contact resistance max	100 m Ω max
Switching current	10 μ A min / 1 A max
Dielectric strength	500 Vrms min

Environmental Data

Operating temperature	-40° C to 85° C
Soldering temperature	Temperature/time profile acc. to CECC00802 para. 6.1, Fig. 3 with peak temperature
Salt mist	IEC 512 test number 11f (96 days)
Damp heat	IEC 512 test number 11c (10 days)

Packaging

8 reels per box. See part number table for other packaging details.

6 Contacts Versions

Part Number	Total Height	Total Length	Terminal Design	Quantity per Reel	Packaging Code	Dimension A	Dimension B
CCM04-5137	1,90	11,8	SMT IN	2400	R242	8,15	10,45
CCM04-5111	1,90	14,3	SMT OUT	2400	R242	12,85	15,15
CCM04-5116	2,10	11,8	SMT IN	1900	R192	8,35	10,65
CCM04-5112	2,10	14,3	SMT OUT	1900	R192	11,95	14,25
CCM04-5120	2,40	14,3	SMT OUT	1900	R192	11,95	14,25
CCM04-5106	2,50	11,8	SMT IN	1900	R192	8,85	11,15
CCM04-5121	2,65	14,3	SMT OUT	1900	R192	11,95	14,25
CCM04-5115	2,80	11,8	SMT IN	1900	R192	8,65	10,95
CCM04-5122	2,90	14,3	SMT OUT	1600	R162	11,95	14,25
CCM04-5107	3,15	11,8	SMT IN	1900	R192	8,85	11,15

2 x 3 contacts SMT IN - Dimensional Drawings

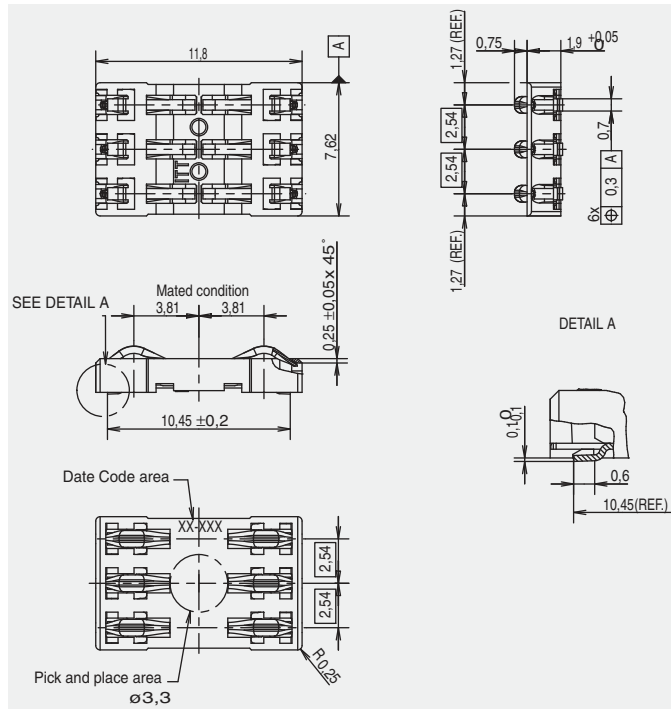

PCB Layout

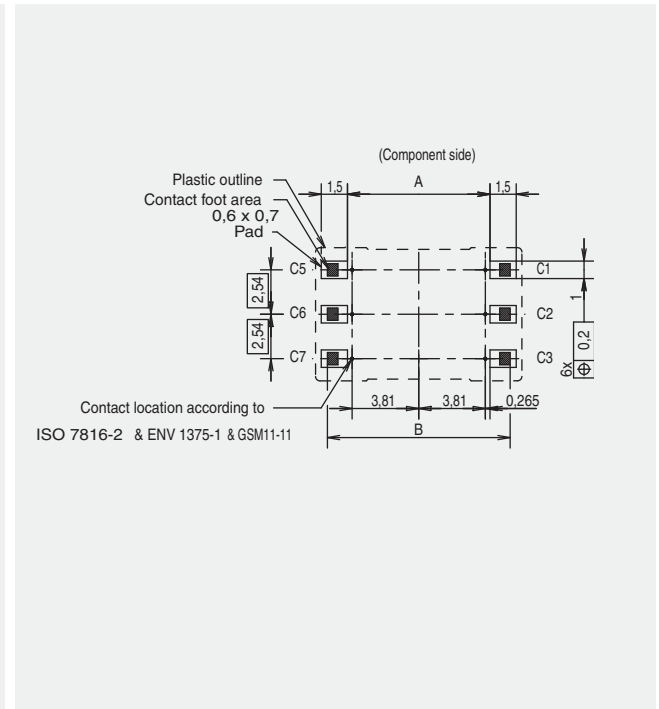

2 x 3 contacts SMT OUT - Dimensional Drawings

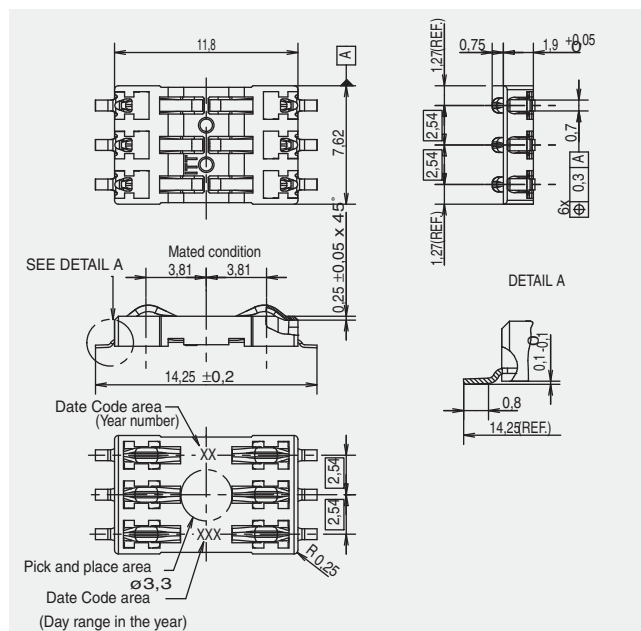

PCB Layout

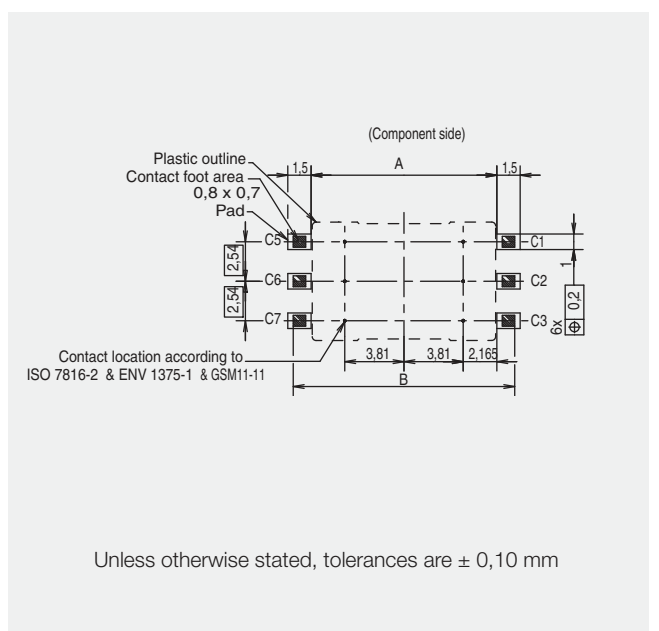

Unless otherwise stated, tolerances are ± 0,10 mm

CCM04 MK III

8 Contacts Versions

Part Number	Total Height	Total Length	Terminal Design	Quantity per Reel	Packaging Code	Dimension A	Dimension B
CCM04-5123	1,90	11,8	SMT IN	2400	R242	8,15	10,45
CCM04-5129	1,90	14,3	SMT OUT	2400	R242	11,95	14,25
CCM04-5113	2,10	11,8	SMT IN	1900	R192	8,35	10,65
CCM04-5130	2,10	14,3	SMT OUT	1900	R192	11,95	14,25
CCM04-5131	2,40	14,3	SMT OUT	1900	R192	11,95	14,25
CCM04-5125	2,50	11,8	SMT IN	1900	R192	8,85	11,15
CCM04-5132	2,65	14,3	SMT OUT	1900	R192	11,95	14,25
CCM04-5127	2,80	11,8	SMT IN	1900	R192	8,65	10,95

2 x 4 contacts SMT IN - Dimensional Drawings

PCB Layout

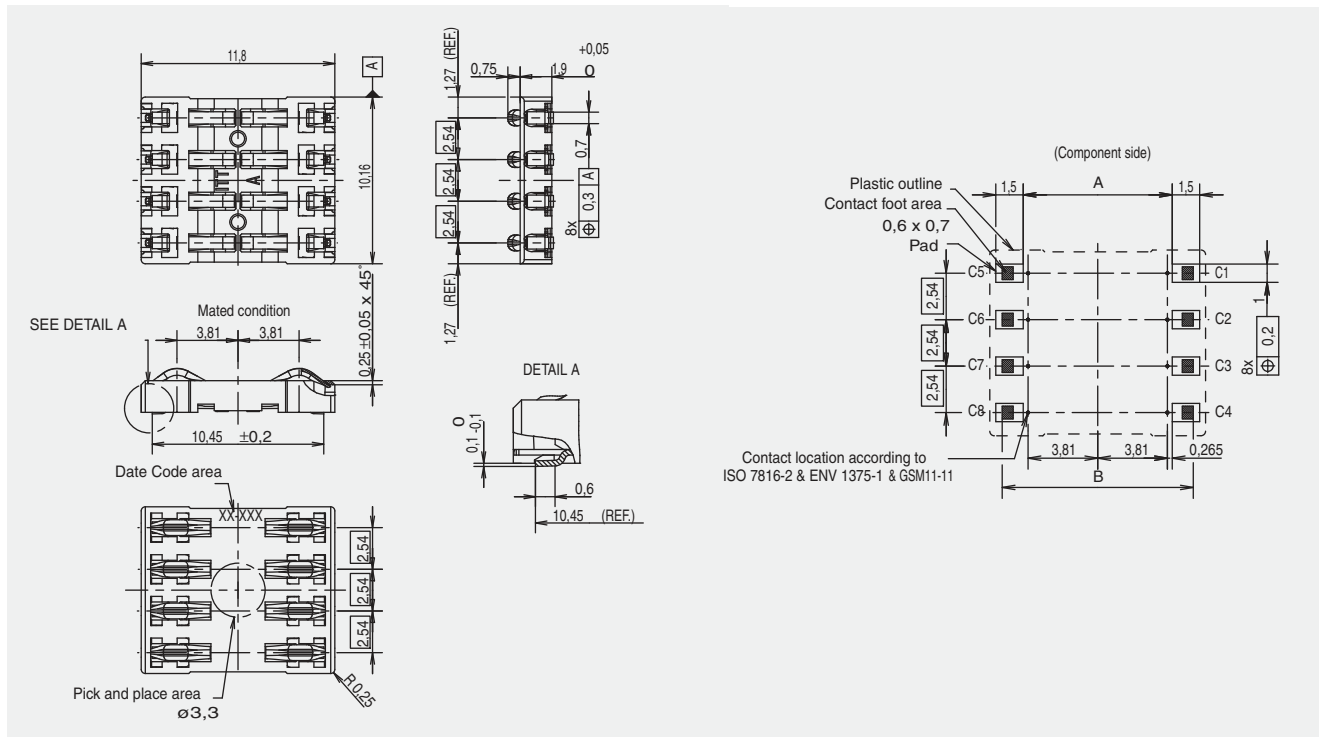

2 x 4 contacts SMT OUT - Dimensional Drawings

PCB Layout

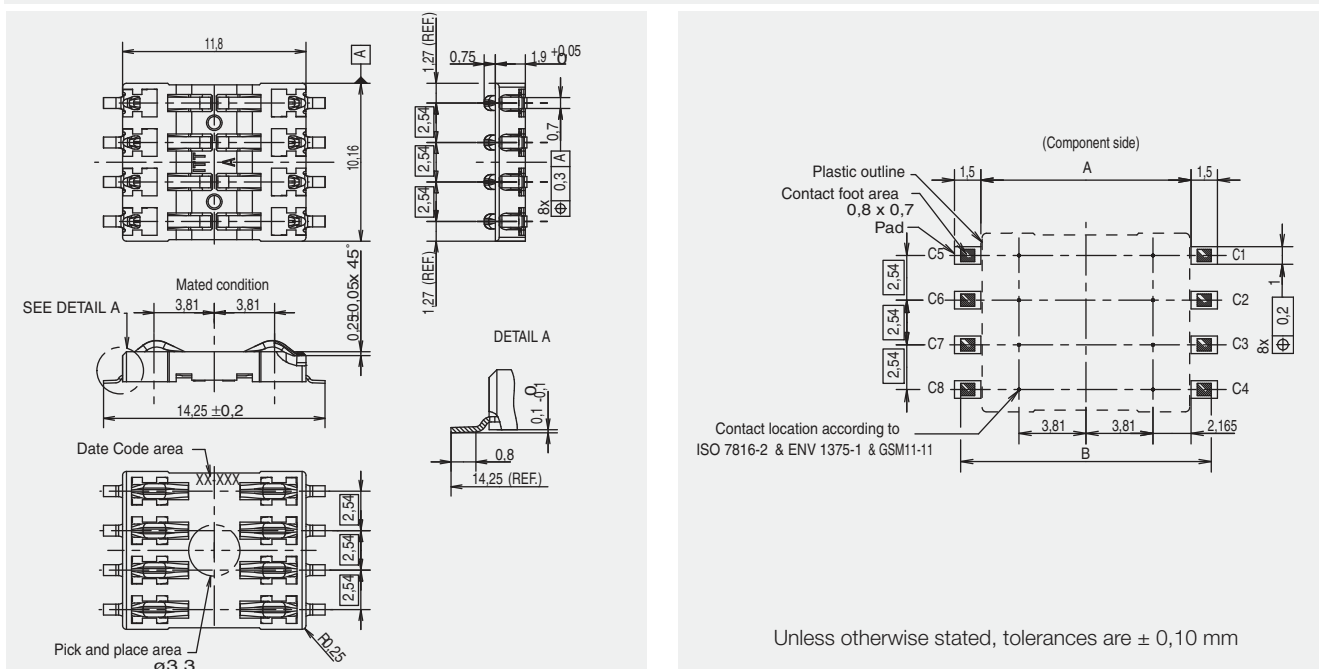

Unless otherwise stated, tolerances are $\pm 0,10$ mm



Dimensions are shown in mm
Specifications and dimensions subject to change

www.ck-components.com